

FIBERGLASS RADIAL BLADE CENTRIFUGAL FANS



MODEL: RBF





Model RBF
Arrangement 9



RBF Fiberglass Impeller



Aerovent, a Twin City Fan Company, certifies that the Model RBF Fiberglass Centrifugal fans shown herein are licensed to bear the AMCA Seal. Certified performance data may be found in Aerovent's Fan Selector software.



Scan the QR code to search Aerovent's AMCA-certified products.



For complete product performance, drawings and available accessories, download our Fan Selector software at aerovent.com.

Model

RBF

The RBF fiberglass fan offers superior corrosion resistance to gases, fumes and vapors. The RBF's fan housings feature solid fiberglass reinforced construction utilizing corrosion grade resin. A glass veil is standard for airstream surfaces providing a resin rich liner to maximize chemical resistance.

The standard resin used for the RBF is resistant to a large variety of alkalis and other chemical agents. When a corrosion resistant fan is required to withstand chemicals that attack glass or polyester resin, special plastic and reinforcing material can be supplied.

Advantages of Fiberglass Fans

- Superior corrosion resistance to gases, fumes and vapors
- Lower maintenance costs
- More economical than stainless steel construction
- Lighter weight than steel

Impeller Design

The RBF impeller features a radial blade design. All impellers are constructed of solid FRP with a steel hub embedded and encapsulated into the back plate.

Size

10" to 57" impeller diameters (255 mm to 1,450 mm)

Performance

Airflow to 38,300 CFM (65,100 m³/hour)

Static pressure to 18" w.g. (4,480 Pa)

Energy Regulations

Aerovent supports energy efficiency regulations enacted by the Department of Energy (DOE) and energy commissions of specific states. The selection and application of fan products is a significant part of these regulations. Engineers and specifiers must understand how to apply Aerovent products to their specific applications to meet efficiency requirements. Aerovent has made significant investments in product testing to assure users will receive the most efficient products available. Developments in the Fan Selector software are in place to help aid in product selection to meet the efficiency requirements as stipulated in the regulations. Visit aerovent.com for the latest on fan energy efficiency regulations.

Construction Features

RBF

Corrosion Resistance

Fan housings are solid FRP hand lay-up construction utilizing corrosion grade flame retardant vinyl ester resin. A glass veil is standard for airstream surfaces providing a resin rich liner to maximize chemical resistance. (See Corrosion Resistance Guide on page 5.)

Impeller/Shaft Assembly

The fan impeller is attached to a 316 SS stepped shaft using a 316 SS retaining plate. The retaining plate is encapsulated in FRP following assembly.

Flanged Outlet

Integral flanged outlet with drilled bolt pattern is standard.

Inlet Connection

Slip-type connection is standard.

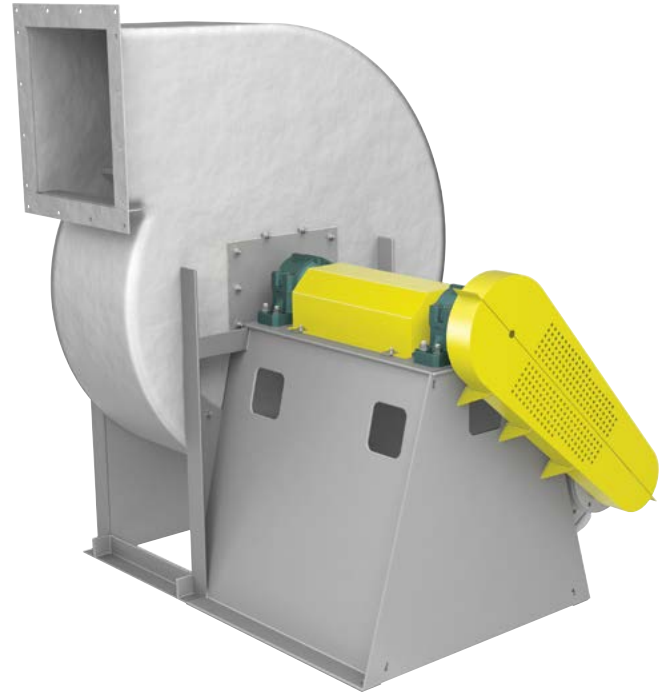

Optional Construction

Optional Materials

- 304 SS or 316 SS bearing pedestals and inlet supports
- Synthetic surfacing veil
- Special resins to suit specific applications
- Fire Retardant Resin reduces the resin's tendency to burn. Antimony trioxide is included to attain a flame spread rating of 25 or less.

Spark Resistant Construction

Spark resistant construction for fiberglass fans is recommended when the fan is handling explosive fumes. Although fiberglass is a non-sparking material, it can build and retain a static charge that can be potentially hazardous. With spark resistant construction, the fan is statically grounded by carbon impregnation to reduce a static charge buildup.



Arrangement 1

Shaft and bearing assembly designed to be driven by a separately mounted motor. Maximum temperature is 200°F.



Arrangement 9

Motor is mounted on the bearing base support. A slide rail base under the motor adjusts for belt tension. Motor is located on the right side as standard (when viewed from the drive end of shaft). Maximum temperature is 200°F.



Arrangement 10

V-belt drive with the motor mounted directly under the fan shaft on a slide rail base. This provides for easy adjustment of the belt tension. Maximum temperature is 200°F.



Accessories

Bolted Inspection Door — Limited access panel bolted and sealed to the housing.

Weather Cover (Arr. 10) — For complete protection of shaft, bearings, motor and drive from weather.

OSHA Type Belt Guard (Arr. 1 & 9) — Provides maximum protection for all personnel and complete coverage of belts and sheaves. Includes a tachometer opening for checking the fan speed.

Shaft & Bearing Guard — Solid sheetmetal enclosure designed to cover the shaft and bearings. Grease lines are accessible for lubrication purposes.

Flanged Inlet — Heavy fiberglass flange; drilling standard.

Unitary Base (Arr. 1) — Unitary bases offered in sizes 15 – 57.

Vibration Isolation — Rubber-in-shear or spring isolators available for all sizes and arrangements.

Housing Drain — Provided with female pipe thread at low point of scroll.

The following table lists gases, fumes and vapors that are commonly exhausted from chemical processes. Using the "Legend of Symbols," the table indicates how Aerovent's standard fiberglass fans will withstand exhausting the particular gas, fume or vapor.

Legend of Symbols

- S — Satisfactory Application
- L — Limited Life or Life Tests Incomplete
- U — Unsatisfactory

This data is based on a maximum temperature of 200°F (93°C).

APPLICATION	SATURATED VAPOR	DRY VAPOR	EXCESS DRY AIR	APPLICATION	SATURATED VAPOR	DRY VAPOR	EXCESS DRY AIR
ACIDS				ALKALINE SALTS			
Acetic	L	S	S	Sodium Bicarbonate	L	S	S
Aqua Regia	U	U	L	Sodium Carbonate	L	S	S
Boric	S	S	S	Sodium Chloride	L	S	S
Butyric	S	S	S	Sodium Cyanide	L	S	S
Carbonic	S	S	S	Trisodium, Phosphate	L	L	S
Chromic	S	S	S	ALKALIS			
Citric	S	S	S	Ammonium Hydroxide	U	L	S
Formic	L	S	S	Calcium Hydroxide	U	L	S
Hydrochloric	S	S	S	Potassium Hydroxide	U	L	S
Hydrocyanic	L	S	S	Sodium Hydroxide	U	L	S
*Hydrofluoric	L	S	S	Sodium Hypochlorite	U	L	S
Hypochlorous	L	S	S	KETONES			
Lactic	S	S	S	Acetone	U	L	S
Maleic	S	S	S	Methyl Ethyl Ketone	U	U	L
Nitric	L	S	S	Methyl Isobutyl Ketone	U	U	L
Oleic	S	S	S	ESTERS			
Oxalic	S	S	S	Butyl Acetate	U	L	S
Perchloric	U	U	U	Ethyl Acetate	U	U	S
Phosphoric	S	S	S	Zinc Acetate	S	S	S
Picric	L	S	S	GASES			
Stearic	S	S	S	Ammonia	L	S	S
Sulfuric	S	S	S	Bromine	U	U	U
Sulfurous	S	S	S	Carbon Dioxide	S	S	S
Tannic	S	S	S	Carbon Disulfide	L	L	S
Tartaric	S	S	S	Chlorine	L	S	S
SALTS, ACID & NEUTRAL				*Fluorine	L	S	S
Alum	S	S	S	*Hydrogen Fluoride	L	S	S
Aluminum Chloride	S	S	S	Hydrogen Sulfide	S	S	S
Aluminum Sulphate	S	S	S	Sulfur Dioxide	S	S	S
Ammonium Chloride	S	S	S	HYDROCARBONS			
Ammonium Nitrate	S	S	S	Benzene	U	U	U
Ammonium Sulphate	S	S	S	Fuel Oil	S	S	S
Calcium Chloride	S	S	S	Gasoline	S	S	S
Calcium Sulphate	S	S	S	Kerosene	S	S	S
Copper Chloride	S	S	S	Lubricating Oil	S	S	S
Copper Sulphate	S	S	S	Mineral Oil	S	S	S
Ferric Chloride	S	S	S	Toluene	U	U	U
Ferric Nitrate	S	S	S	Vegetable Oil	S	S	S
Ferric Sulphate	S	S	S	Naphtha	S	S	S
Magnesium Salts	S	S	S	Methane	S	S	S
Nickel Salts	S	S	S	Butane	S	S	S
Potassium Chloride	S	S	S	Propane	S	S	S
Potassium Nitrate	S	S	S	Xylol	S	S	S
Potassium Sulphate	S	S	S	CHLORINATED SOLVENTS			
Sodium Chloride	S	S	S	Carbon Tetrachloride	L	S	S
Sodium Sulphate	S	S	S	Chlorobenzene	U	U	U
Sodium Sulphite	S	S	S	Chloroform	U	U	U
Stannous Chloride	S	S	S	Perchloroethylene	U	U	L
Zinc Chloride	S	S	S	Trichloroethylene	U	U	L
Zinc Sulphate	S	S	S				
Alcohols	S	S	S	Glycols	S	S	S

*Synthetic Surfacing Veil Required

Arrangement 10

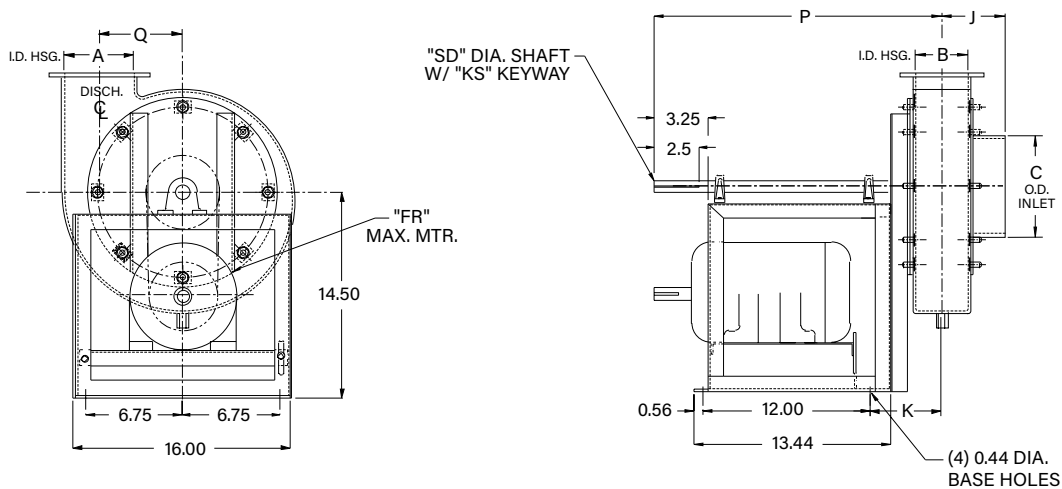

NOTE: Arrangement 10 available for sizes 15 through 36. Contact factory for dimensional data.

SIZE	A	B	C	FR	HD	HE	HF	HG	HH
10	4.00	3.38	6.38	56	8.25	8.25	8.25	7.94	7.44
12	5.00	3.88	7.38	145T	9.50	9.25	9.50	9.06	8.69
13	7.06	5.50	8.38	145T	11.78	11.78	11.75	11.31	10.44

SIZE	HJ	HK	HN	J	K	KS	P	Q	SD
10	8.97	13.13	9.56	4.06	4.63	.25 x .13	19.06	6.06	1.00
12	10.28	15.25	11.25	4.31	4.88	.25 x .13	19.31	7.25	1.187
13	11.84	17.38	12.68	4.81	5.69	.25 x .13	20.13	7.31	1.187

Dimensions are not to be used for construction.

R-32033-00A

Fan Discharge Options

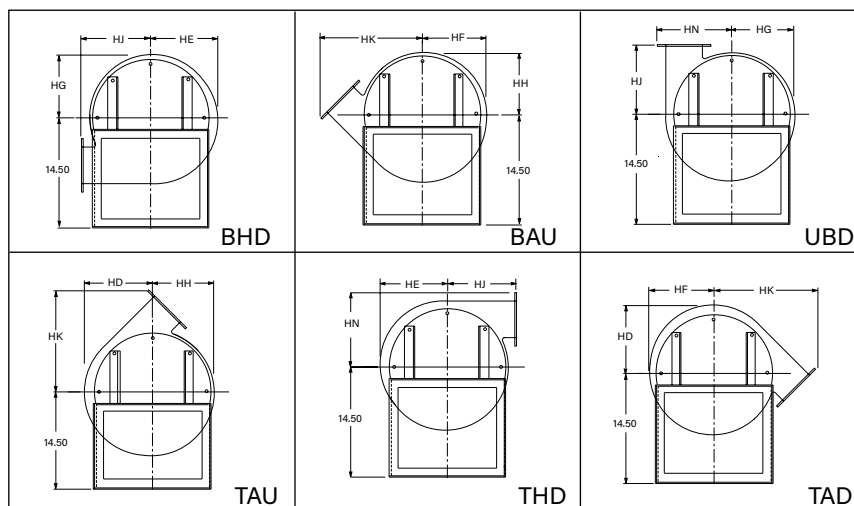



Model RBF

Fans shall be of the Radial Blade Fiberglass (Model RBF) Centrifugal type as manufactured by Aerovent, Minneapolis, Minnesota, and shall be of the size and capacity as indicated in the fan schedule. Fans shall be tested and certified in accordance with ANSI/ASHRAE 51 and ANSI/AMCA 210 test codes and guaranteed by the manufacturer to deliver at the rated published performance levels. In addition, each unit shall be factory run tested prior to shipment.

IMPELLER — Fan impeller shall be constructed using glass cloth impregnated with vinyl ester resin. Impellers shall be statically and dynamically balanced.

HOUSING — The housing shall be of solid construction utilizing corrosion resistant fiberglass reinforced resin mounted on an all welded, heavy-gauge steel base with Arrangement 1, 9 or 10. Sizes 10, 12 and 13 in Arrangement 10 only. All airstream hardware shall be of FRP encapsulated 316 stainless steel for maximum corrosion resistance.

BEARINGS — Bearings shall be of a regreasable pillow block type and shall have a minimum L-10 life as defined by AFBMA of at least 40,000 hours (200,000 hours average life).

DRIVE — The belts and sheaves furnished by the manufacturer shall be selected to provide additional allowances of 1.3 to 2 times the normal satisfactory capacity.

MOTOR — Fan motors shall be foot mounted NEMA Design B, heavy-duty industrial, continuous-duty, ball bearing, variable torque type suitable for operation on voltage, phase and hertz, as listed in the fan schedule. Motor bearings shall have a minimum L-10 life as defined by AFBMA of at least 40,000 hours (200,000 hours average life).

BALANCING — The impeller assembly shall be statically and dynamically balanced in accordance with ANSI/AMCA 204-96 "Balance Quality and Vibration Levels for Fans" to Fan Application Category BV-3, Balance Quality Grade G6.3. In addition, belt driven fan impellers shall be balanced on the fan shaft after final assembly in the fan casing, in the manufacturing facility, to the following peak velocity values, filter-in, at the fan test speed:

Fan Application Category	Rigidly Mounted (in./s)	Flexibly Mounted (in./s)
BV-3	0.15	0.20

FINISH — All steel parts are finished with light gray epoxy enamel paint. All fiberglass parts are coated inside and outside with resin (with UV inhibitor), approximately 10 mils in thickness, to seal the surface and provide a smooth, shiny finish. Synthetic surface veil is also available as an optional finish.

ACCESSORIES — The fan(s) shall be furnished complete with:

- Bolted Cleanout Door
- Weather Cover (Arr. 10, Sizes 10" – 36" only)
- OSHA Type Belt Guard (Arr. 1 & 9, Sizes 15" – 57")
- Shaft & Bearing Guard
- Flanged Inlet (Drilling Standard)
- Spark Resistant Construction
- Housing Drain
- Vibration Isolation (RIS/Spring)
- Unitary Base (Arr. 1)

GUARANTEE — The manufacturer shall guarantee the workmanship and materials for its roof and wall mounted centrifugal exhaust fans for at least one (1) year from startup or eighteen (18) months from shipment, whichever occurs first.



**WALL MOUNTED FANS | TUBEAXIAL & VANEAXIAL FANS | CENTRIFUGAL FANS & BLOWERS |
ROOF VENTILATORS | AIR HEATERS & COOLERS | AIR MAKE-UP | FIBERGLASS FANS | CUSTOM FANS**

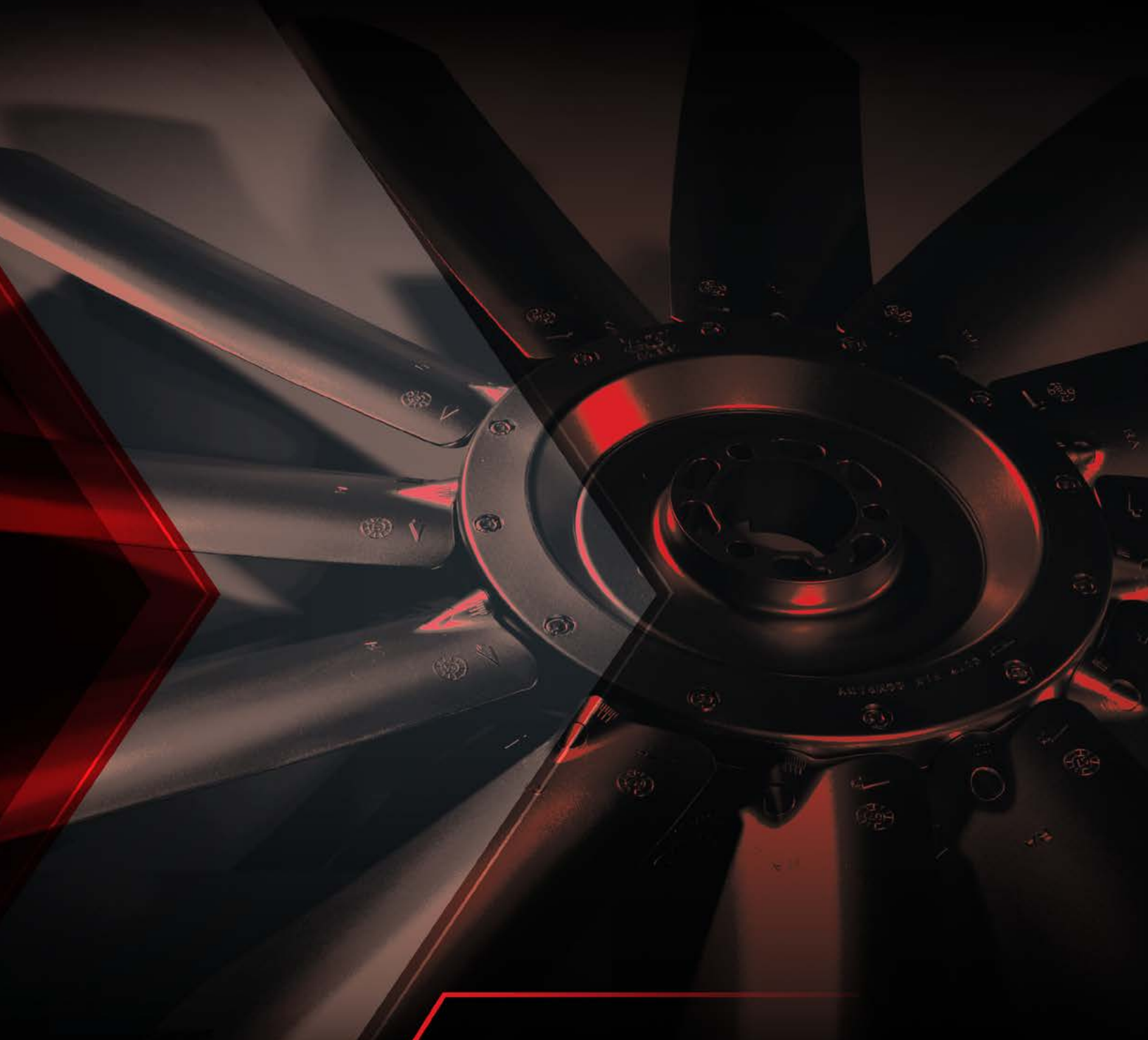

AEROVENT 
INDUSTRIAL VENTILATION SYSTEMS

AEROVENT.COM

5959 Trenton Lane N. | Minneapolis, MN 55442 | Phone: 763-551-7500 | Fax: 763-551-7501