



Throughout this manual, there are a number of HAZARD WARNINGS that must be read and adhered to in order to prevent possible personal injury and/or damage to equipment. Two signal words "WARNING" and "CAUTION" are used to indicate the severity of a hazard and are preceded by the safety alert symbol.

⚠ WARNING

Used when serious injury or death MAY result from misuse or failure to follow specific instructions.

⚠ CAUTION

Used when minor or moderate injury or product / equipment damage MAY result from misuse or failure to follow specific instructions.

NOTICE

Indicates information considered important, but not hazard-related.

SAFETY INSTRUCTIONS

Indicates specific safety-related instructions or procedures.

It is the responsibility of all personnel involved in installation, operation and maintenance to fully understand the

⚠ Warning and ⚠ Caution procedures by which hazards are to be avoided.

CONTENTS

Introduction.....1

Personal Protection.....1

Hazardous Materials.....2

Installation

 Shipping and Receiving2

 Handling2

 Unit Storage2

 Foundations and Supporting Structures

 - Industrial Fans3

 Fan Installation - Factory Assembled Units3

 Fan Installation - Disassembled Units4

 Bearing Installation5

 Grouting5

 Drive Mounting6

 Flexible Couplings.....6

 Duct Connections6

 Guards and Enclosures.....6

 Electrical Supply and Controls.....7

Maintenance

 Guards and Access Doors10

 Motor Maintenance10

 Drive Maintenance10

 Bearing Maintenance10

 Impeller and Shaft Maintenance.....10

 Structural Maintenance.....10

Fan Operation

 Proper Use and Application10

 Sound11

 Operation Checklist.....12

 Optional Accessories12

 Troubleshooting Guidelines13

 Disposal13

Appendix A - Commercial Ventilator Installation

 Instructions.....13

Appendix B - Axial Fans, Blade Adjustments..... 14-16

INTRODUCTION

This manual has been prepared to guide the users of fans in the proper installation, operation and maintenance procedures to insure maximum equipment life with trouble-free operation. Personnel operating or maintaining this equipment shall be trained in the proper procedures for doing so.

Since many fans of this type have custom features or components, please refer to the attached documentation and appendices for additional information. When manufacturers of components provide detailed installation and operation manuals, they will be provided. Because of the wide variety of equipment covered in this manual, the instructions given here are general in nature.

For safe installation, startup and operational life of this equipment, it is important that all involved with the equipment be well versed in proper fan safety practices and read this manual. Please review the safety section before beginning any work. It is the user's responsibility to make sure that all requirements of good safety practices and any applicable safety codes are strictly adhered to. Only properly trained personnel should operate and maintain this equipment.

PERSONAL PROTECTION

For safety reasons maintenance personnel should wear personal protection equipment when attempting to maintain fans. People with long hair are advised to tuck hair back possibly into a cap.

Personal protection equipment should include the following:

- Safety glasses or goggles approved by local safety authority
- Protective shoes with steel toecaps and oil resistant soles
- Heavy gloves that can cope with sharp edges or exposure to hazardous chemicals. This is especially important when hazardous residues are present in fans.
- Breathing apparatus if toxic gases or vapors are expected to be present.
- Close fitting clothing

Do not wear:

- Rings
- Bracelets
- Necklaces
- Loose items of clothing

It is the responsibility of the maintenance personnel to determine that the lighting is sufficient for the work being performed. Additional portable lighting may be required as there are no lighting fixtures supplied with the fans.

HAZARDOUS MATERIALS

Twin City Fan Companies, Ltd. is not always made aware of the materials that may be handled with a fan and therefore can not warn the user of these hazards. Because of this, the end user must identify the material hazards present and indicate this on the fan with a warning label. If there is risk of residual hazardous material being left in a fan if the gas or vapor being handled can accumulate as a deposit, all maintenance and operation personnel must be trained to handle such hazards before having access to the fan.

Lubricants used on fan components could be hazardous if they contact someone’s eyes or are consumed.

For additional general safety practices for air moving equipment, see AMCA Bulletin 410.

INSTALLATION

Shipping and Receiving

All Twin City Fan Companies, Ltd. products are carefully constructed and inspected before shipment to insure the highest standards of quality and performance. Compare all components with the bill of lading or packing list to verify that the proper unit was received. Check each unit for any damage that may have occurred in transit. Any damage should be reported immediately to the carrier and the necessary damage report filed.

Handling

Handling of all air moving equipment should be conducted by trained personnel and be consistent with safe handling practices. Verify the lift capacity and operating condition of handling equipment.

 CAUTION
Maintain handling equipment to avoid serious personal injury.

During transportation and handling, caution must be exercised to lift only in the designated locations. On most units, lifting lugs are fashioned to protect the fan and fan housing from damage. Secure lifting equipment to all provided lifting lugs to avoid instability while moving the equipment. Units shipped completely assembled may

Figure 1. Lifting Lug Locations

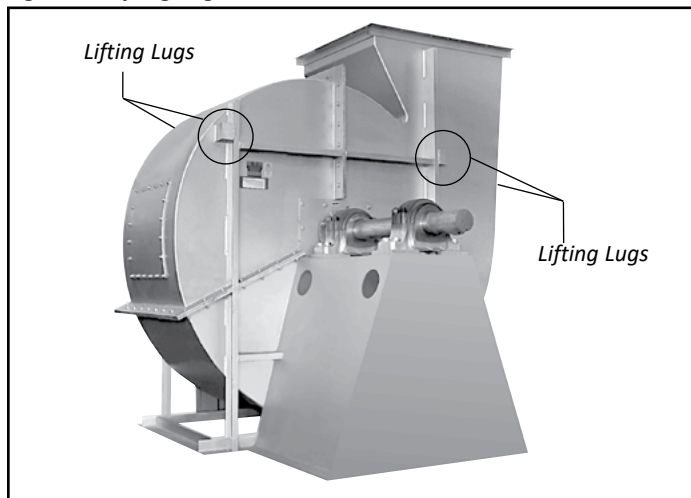

be lifted with slings and spreader bars. (Use well-padded chains, cables or nylon straps.) Never lift a fan by the inlet or discharge flange, shafting or drives, impeller, motor or motor base, or in any other manner that may bend or distort parts. Never lift with slings or timbers passed through the fan inlets.

Partial or disassembled units require special handling. All parts should be handled in a fashion that protects the coatings and parts from damage. Components should be handled such that forces are not concentrated to avoid bending or distortion.

The housing should be lifted using straps and spreaders. Do not distort housing or side plates when lifting.

 CAUTION
Bearing pedestals should be lifted using straps or padded chains. Under no circumstance should an attached or separated bearing pedestal be lifted by the shaft, bearings, drives, motor or impeller.

The shaft and impeller assembly may be lifted using a hoist and a spreader with a sling around the shaft at points nearest the impeller. Use the spreader bar to ensure that the slings do not push against the sides of the impeller as this may distort the impeller. Take care not to scratch the shaft where the impeller or bearings will be mounted. Never lift or support the assembly by the impeller. Always support the assembly by the shaft when lifting or storing. Do not support the shaft or the impeller on the housing sides.

Impellers shipped separately can be lifted by slings running between the blades or around the hub. Never lift the impeller by blades or flanges. Always transport impellers by lifting. Do not roll the impeller as this can damage coatings and change the balance of the impeller.

Bent shafting is a source of vibration and bearing failure, so handle the shaft with care. Any scratches on the shaft may be removed with fine emery cloth or a stone.

For roof ventilators, also see instructions specific to handling roof ventilators in Appendix A.

Pins to hold insulation to the housing are supplied for some high temperature fan designs. Use caution when handling and working around fans that have these insulation pins as the points are sharp.

Unit Storage

If fan installation is to be delayed, store the unit in an environmentally stable and protected area. Vibration should not exceed 0.051 mm peak – peak displacement at the storage site unless the fan is properly isolated from the vibration. The unit should be reasonably protected from any accidental impacts. Cover the fan to protect coatings and to prevent any foreign material or moisture from entering the inlet or discharge. Take care to protect the motor, drives and bearings. The following precautions should be taken during extended storage to ensure the equipment is not damaged:

- Extended storage requires monthly inspections. Check for corrosion or damage to the unit and for debris within the fan.
- Bearings tend to take on moisture if the atmosphere they are stored in is not at a constant temperature. To avoid corrosion, it is necessary to keep the bearings full of grease and to rotate them periodically. Even when full of grease, bearings will take on moisture, so it is necessary to purge the bearings with new grease to expel moisture every thirty days. It is recommended that the bearings be purged with grease while being rotated by hand. Do not use high-pressure greasers as they may ruin the bearing seals.
- The drives and belts should be removed if the fan is to be stored for a prolonged period. The drives should be labeled

for service and stored in a dry place. Belts should be removed, coiled without kinks, placed in a heavy carton, and stored in a dry, well-ventilated place. To prevent belt deterioration storage conditions should not exceed 85°F and 70% humidity. If belts show signs of deterioration, they should be replaced prior to startup.

- Motors should be stored in a clean, dry, vibration-free location. The packaging should be opened up enough to allow air circulation around the motor. The winding temperature should be kept slightly above that of the surroundings to prevent condensation. This can be accomplished by energizing the internal heaters, if the motor is so equipped, or by using space heaters. If it is impossible to heat the windings, the motor should be wrapped tightly with a waterproof material that also encloses several bags of desiccant. Replace the desiccant regularly to prevent moisture problems. The motor rotor should also be rotated regularly (monthly) to assure the bearing parts are well greased.

Foundations and Supporting Structures

— Industrial Fans

The best means of floor mounting a fan is on a well-designed, flat, level concrete foundation. The foundation should have a mass of at least three times that of the supported assembly. The foundation should extend 150mm beyond the outer dimensions of the fan and driver; however, it should be no more than twice the area required for the equipment. If it is made larger, the mass should be increased accordingly to resist rocking modes of vibration. J or T type anchor bolts using one size smaller than the nominal dimension of the base hole shall be used. Anchor bolts should be tied into the reinforcing bar of the foundation for the foundation. A pipe sleeve with a diameter of 2 to 2½ times the anchor bolt diameter should be provided around the anchor bolt for final adjustment (see Figure 2). The mounting surface of the foundation should be smooth for good shim contact. When deciding the thickness of the foundation,

Figure 2. Typical Foundation Section

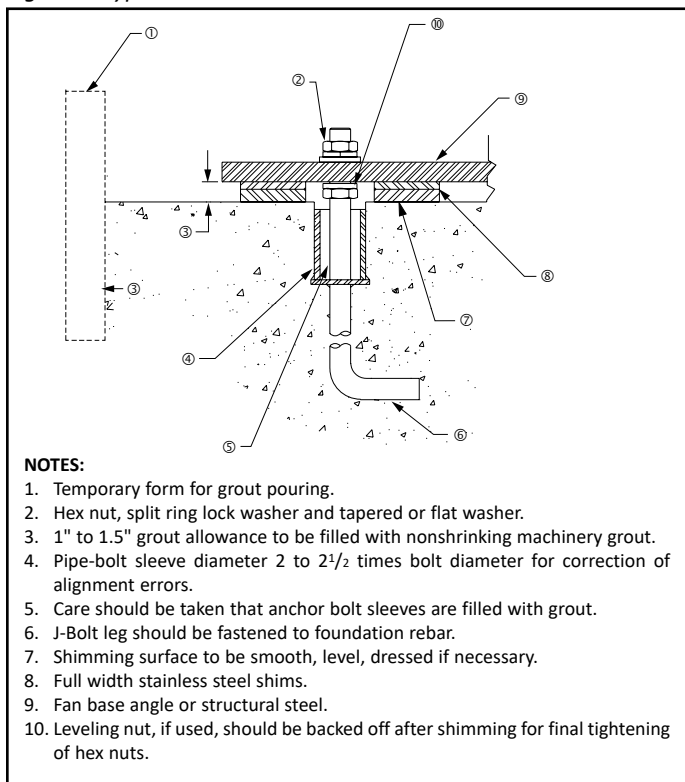

approximately 25 to 40mm height should be allowed for shimming, grouting, leveling, washers, nuts, etc.

The foundation plan on the customer submittal drawing indicates the mounting hole size and locations on the fan.

If a structural steel base or platform is to be used, the structure must be designed for the weight of the fan, live loads imposed by rotation of the rotor and driver, and any external live loads. The structure should be designed to ensure that no natural frequency will occur within 30% of the fan speed. This is especially true if the structure supports more than one fan.

Any ducting should have independent support. Do not use the fan to support ducting. The fan frame can be designed to carry some external loads. Consult the factory if this is a concern. Isolating the fan from ductwork with flex connections eliminates transmission of vibration. Fans handling hot gases require expansion joints at both the inlet and discharge to prevent excessive loads caused by thermal growth. Refer to AMCA Publication 201 for good practices in ductwork geometry and configuration. When possible, ductwork shall be located where there is least risk of personnel tripping, walking into or falling over the ductwork. If not possible, warnings shall identify this hazard.

See Appendix A Commercial Ventilator Installation Instructions for commercial ventilator foundation details.

Fans should not be located underneath other machinery where there might be a risk of harmful liquid falling onto fans from above.

Fans should be installed where they are readily accessible to maintenance personnel, so that such personnel are not required to stoop or crawl to access fans.

Fan Installation - Factory Assembled Units

General instructions for industrial centrifugal fans – For Axial fans and commercial ventilators, follow steps below noting instructions specific to those fan types in Appendix A and B.

Follow proper handling instructions as given earlier.

1. Move the fan to the final mounting position.
2. Remove skid, crates and packing materials carefully.
3. If vibration isolation is to be used, place isolation base on mounting bolts. Line up holes in fan base with bolts as indicated on the foundation plan of the customer submittal drawing.
4. Consult each specific fan's submittal drawing for proper installation arrangement and mounting dimensions. Place the fan on mounting structure. Carefully level the unit (checking the level on the shaft) on the foundation and shim as necessary using stainless steel shims on both sides of each anchor bolt. Anchor bolts are to be pre-tensioned per Table 1. For metric grade bolts or materials not shown in Table 1, check with bolt manufacturer for the proper torque. (See details specific to commercial ventilators in appendix A for this step).
5. Check the alignment of the bearings. Shim or reposition the bearings if necessary. In many split housing roller bearings, the gap between the seal carrier and housing can be measured with a feeler gage. The variation in this gap should be less than half of the maximum gap measured. In roller bearings where this gap is not visible, alignment can be verified by verifying the bearing is square with the pedestal top. In ball bearings, the bearing outer ring swivels in the housing to accommodate a small amount of misalignment. Verify bearing set screws, cap bolts and collars are tightened per Tables 2a, 2b and 2c.
6. Check face alignment of sheaves on belt driven fans. Parallel alignment should be within 5mm per meter of center distance. Angular Misalignment should be less than 1 degree. Check and record tension of belts to see if it is sufficient. Proper belt tension is specified on the included datasheet. If belt tension needs adjustment, instructions on belt tensioning are given in

the Drive Mounting section of this manual. Sheaves on belt driven fans are often provided with taper lock bushings. When tightening bushing bolts, proceed in a progressive manner to avoid cocking the tapered surfaces between the bushing and the sheave. Bushing bolt torque specifications are indicated in Table 3.

7. Check alignment of factory mounted couplings, as they are subject to misalignment during shipment. Realign if necessary in accordance with the instructions that are included with the shipment.

NOTICE

Most couplings need lubrication.

8. Make sure there is no rubbing or binding and that the impeller to inlet cone or impeller to fan housing clearances and overlap are correct. Overlap values or other dimensions to verify proper impeller location are given in the included documentation specific to the fan. Impeller clearance should be verified to match the specified value and be uniform. The measured values should be recorded.
9. Check the tightness of the impeller on the shaft per Table 4. The measured torque should be recorded.
10. Check the tightness of foundation bolts, motor mounting bolts and bearing mounting bolts per Table 1. For metric bolts or grades not specified in Table 1, check proper torque values per the bolt manufacture.
11. Check that bearings are fully lubricated and check the oil level in the static oil lube systems (if supplied).
12. Install any accessories shipped loose from the factory.

Fan Installation - Disassembled Units

General instructions for industrial centrifugal fans – For Axial fans (including mounting arrangements for inline centrifugal fans), follow assembled fans instructions above and use Appendix B for assembly details.

A unit is considered “disassembled” if any component required for proper operation is shipped or supplied separately or in pieces. Reference earlier instructions concerning proper handling of fan components. Assembly shall only be performed by trained personnel familiar with the assembly of this type of equipment.

1. Move the lower half of the housing to its mounting location (split housing).
2. Remove skids, crates and packing materials carefully.
3. If vibration isolation is to be used, place the vibration isolation base on mounting bolts. Line up holes in fan base with bolts.
4. Place the lower housing on the mounting structure. Carefully level the lower housing on the foundation and shim as necessary using stainless steel shims on both sides of each anchor bolt.
5. If the bearing pedestal(s) are separated they should be installed next.
 - a. Move bearing pedestal(s) to mounting location.
 - b. Put vibration base, if any, in place. Set pedestal(s) on bolt(s).
 - c. Do not distort bearing pedestal by forcing it to align with a non-level foundation. Shim beneath the pedestal as necessary.
- d. Check the bearing centerline height. Adjust the height to match centerline height of the housing. High temperature units may require a lower housing centerline when cold so that it will be centered when hot.
- e. Bring the bearing pedestal into square with the housing using careful measurements or a large square.
- f. Bolt the pedestal into position.

6. If the impeller and shaft were shipped unassembled, you must now install the shaft in the impeller.
 - a. First use solvent to clean the protective coating off the shaft. Check all surfaces for corrosion or nicks and clean if necessary with fine emery cloth or a stone. After thoroughly cleaning the shaft with solvent, do not touch it with bare hands as perspiration can cause rust or pitting over time.
 - b. Remove keys from the shaft.
 - c. Clean the inside of the impeller bore with solvent. Make sure the set screws will not interfere when inserting the shaft into the impeller bore.
7. Arrangement 1, 9 or 10: Drive Component Assembly:
 - a. Insert shaft into impeller from back side of impeller (Figure 3).
 - b. When shaft is flush with impeller hub, put key into keyway and tighten impeller set screws (for straight bore hubs) or for bushing bore hubs, progressively tighten the bushing bolts per Table 3. Record the measured torque value.
 - c. Insert shaft through opening in drive side. (If splithoused unit, lower into position.)
 - d. Install bearings onto shaft. Do not tighten bearing set screws at this time. The bearing housing should be perpendicular and the bearing base parallel to the axis of the shaft to prevent loads caused by misalignment.
 - e. Mount assembly, bolt bearings to drive stand. Shaft must be parallel with side of bearing pedestal.

Figure 3. Drive Component Assembly

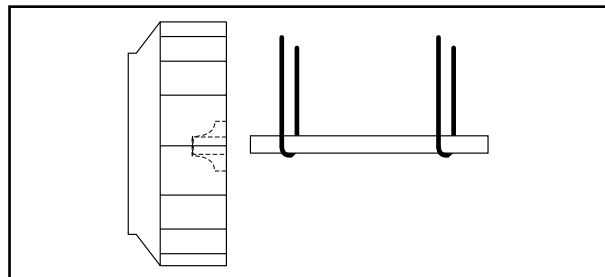

8. Arrangement 3 (Split-housed) units (See Figure 4):
 - a. Parts on DWDI units are assembled in the following order as viewed from opposite drive side: Bearing bar assembly and opposite bearing, funnel (housing side), impeller (housing side), funnel, drive side bearing bar assembly, drive bearing and sheaves. Mount bearing bar assembly to housing. Center impeller in funnels.
 - b. Parts on SWSI units are assembled in the following order as viewed from opposite drive side: Bearing bar assembly and opposite bearing, funnel (housing side), impeller (housing side), drive side bearing bar assembly, drive bearing and sheaves. Mount bearing bar assembly to housing.
 - c. Assemble parts in above order on shaft.
 - d. Move assembly into position. Lightly bolt bearings into place.

Figure 4. Split-Housed Drive Component Assembly

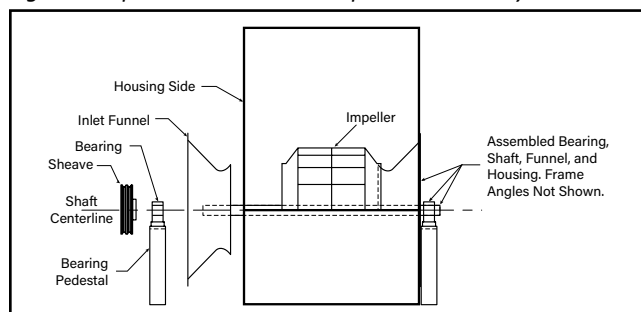

- e. Shaft should be parallel with discharge of housing. Move bearings to accommodate. Follow bearing alignment instructions per step 5 in factory assembled units section above.
 - f. Level shaft; shim bearings if required. Tighten bearing set screws.
9. Install motor on base. Carefully align shafts for drive installation.
10. Mount drives as follows:
- a. Slip (do not pound) proper sheave onto corresponding shaft.

CAUTION

Placing fan sheave on motor can overspeed impeller and cause structural failure.

- b. Align sheaves with a straightedge extended along the perimeters of both sheaves, just making contact in two places on outside perimeters of both sheaves (see Figure 5). Parallel alignment should be within 5mm per meter of center distance. Angular Misalignment should be less than 1 degree.
 - c. Tighten down sheave bolts.
 - d. Install a matched set of belts. Adjust belt tension as indicated in "Drive Mounting" step #3.
 - e. Tighten belts to proper belt tension. Record the belt tension used. See drive mounting section for tensioning instructions. Proper tension is specified in the datasheet included with the fan.
11. Fans that have motors and drives mounted at the factory are trim balanced prior to shipment. This is not possible on units that are shipped without motors and drives. The addition of drive components in the field can create unbalance forces. Twin

- City Fan Companies, Ltd. recommends final balancing of the unit after the drive components are installed. Failure to do so voids the Twin City Fan Companies, Ltd. warranty.
12. Repeat the installation checks indicated for factory assembled units to assure proper tightness and alignment of all components.

Bearing Installation

Bearings are only to be field installed when accompanied by installation instructions from the bearing manufacturer. When field installation is required, follow the manufacturers instructions carefully to install bearings.

Grouting

Grouting is the final installation step. Check all shims before grouting to make sure that the fan is resting evenly on all points with anchor bolts secured to hold the shim. Use forms with sufficient space allowed for working the grout. The concrete foundation should be clean and well moistened before pouring grout. Use a commercial grade non-shrinking grout and be especially sure when pouring grout that the anchor bolt sleeves are filled. Refer to Figure 2 for a detail of a proper foundation, grout allowance and anchor bolt sleeves.

Figure 5. Sheave Alignment

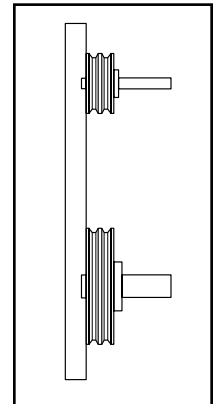

Table 1. Bolt Tightening Torque

Size	Grade 2		Grade 5		Grade 8		Aluminum		Stainless	
	(Ft - lbs)	(N - m)	(Ft - lbs)	(N - m)	(Ft - lbs)	(N - m)	(Ft - lbs)	(N - m)	(Ft - lbs)	(N - m)
1/4 - 20	5.5	7.5	8	10.8	12	16.3	3.8	5.2	6.3	8.5
5/16 - 18	11	15	17	23	25	34	6.7	9.1	11	15
3/8 - 16	22	30	30	41	45	61	11.9	16	19	26
7/16 - 14	30	41	50	68	70	95	19	26	31	42
1/2 - 13	55	75	75	102	110	149	26	35	43	58
5/8 - 11	100	136	150	203	220	298	59	80	92	125
3/4 - 10	170	230	270	366	380	515	81	110	128	174
7/8 - 9	165	224	430	583	600	813	125	169	194	263
1 - 8	250	339	645	874	900	1220	184	249	287	389
1 1/4 - 7	500	678	1120	1518	1500	2034	336	456	523	709

Table 2a. Bearing Cap Bolt Torque Specifications (see page 8)

Table 2b. Metric Set Screw Torque Specifications

METRIC SHAFTS			SET SCREW SIZE					LOCKING COLAR SCREW SIZE			
Manufacturer	BRG ID	Units	M5	M6	M8	M10	M12	M4	M5	M6	M8
Dodge	S2000	N-m	-	-	17.8	35	57	-	-	-	-
Dodge	SCAH	N-m	3.4	6.9	16	28	51	5.85	10.75	20.5	45
Dodge	SCMAH	N-m	3.4	6.9	16	28	51	5.85	10.75	20.5	45
SKF	SY	N-m	See Below						4.2	7.4	

Manufacturer	BRG ID	Units	SY BEARING DIAMETER				PB224 BEARING DIAMETER				
			12-35mm	40-45mm	50-65mm	70-100mm	25,30mm	35-50mm	55mm	60-80mm	90,100mm
SKF	SY	N-m	4	6.5	16.5	28.5	-	-	-	-	-
Linkbelt	PB224	N-m	-	-	-	-	21	37	52	77	153

Table 2c. IP Set Screw Torque Specifications (see page 9)

Table 3. Browning Split Taper Bushing Tightening Torque

Bolt Size	Bushing Type	Iron/Steel Hub, Sheave		Aluminum Hub	
		Ft - lbs	N - m	Ft - lbs	N - m
1/4 - 20	H	8	11	8	11
5/16 - 18	P, B	17	23	13	18
3/8 - 16	Q, R	30	41	24	33
1/2 - 13	S	70	95	-	-

Drive Mounting

Mount drives as follows:

- Slip (do not pound) proper sheave onto corresponding shaft.

⚠ CAUTION

Placing fan sheave on motor can overspeed impeller and cause structural failure.

- Align sheaves with straightedge extended along sheaves (see Fig. 5), just making contact in two places on outside perimeters of both sheaves. This “four-point” alignment may also be checked with a string tied to the shaft behind one of the sheaves. The string is then pulled taut over the faces of the sheaves to check the alignment at the four points at the outside perimeters. Each sheave should be rotated about one-half revolution during this check to look for excessive runout or a bent shaft. Parallel alignment should be within 5mm per meter of center distance. Angular Misalignment should be less than 1 degree.
- Install and tighten the belts. Proper belt tension is specified on the included documentation. Belts are tensioned as follows: Post type, saddle base, slide rails and slide base types use one or more bolts held by retaining nuts to adjust the motor position. Loosen the retaining nuts and adjust the bolts to push or pull the motor until the belts reach their specified tension. Tighten the retaining nuts per torque specifications in Table 1.
- Run the drive for a few minutes to seat the belts. When tightening the belts, slide the motor in to slip the belts on. Do not use a pry bar, as this may damage the belt cords. Retighten the belts to the proper tension if necessary. Recheck sheave alignment.
- After initial installation of belts, recheck belt tension and alignment as indicated in Table 7.

Flexible Couplings

These instructions are general for the installation of several types of flexible couplings and should not be used as a substitute for more specific manufacturer’s instructions. The coupling manufacturer’s installation data is included with the supplied datasheet (when applicable) and will give specific dimensions for alignment limits, lubricants, etc.

Before preparing to mount the coupling, make sure that all bearings, inlet vanes, shaft seals or other components have been installed on the shaft.

When mounting and keying the coupling halves to the shaft, follow supplied instructions for heating and shrink fitting. Set the coupling halves for the normal gap specified by the manufacturer. Coupling gap is illustrated in Figure 6.

The two types of misalignment are illustrated in Figure 6. Typically angular alignment is checked with feeler gauges between the hub faces. When angular alignment has been adjusted to manufacturer’s specification by shimming, if necessary, parallel alignment can be checked with a straightedge and feeler gauges on the hub halves’ O.D. When shimming has brought parallel alignment within specification, angular alignment and gap should again be checked, and adjustments made if necessary. A dial

Table 4. Set Screw Tightening Torque (other than bearing set screws)

Set Screw Size	Steel Set Screws		Stainless Set Screws	
	Ft - lbs	N - m	Ft - lbs	N - m
1/4 - 20	5.5	7.5	5.8	7.9
5/16 - 18	11	15	11	15
3/8 - 16	22	30	19	26
7/16 - 14	30	41	28	38
1/2 - 13	55	75	42	57
5/8 - 11	100	136	82	111
3/4 - 10	170	230	115	156
7/8 - 9	165	224	-	-
1 - 8	250	339	-	-
1 1/4 - 7	500	678	-	-

Figure 6. Coupling Alignment

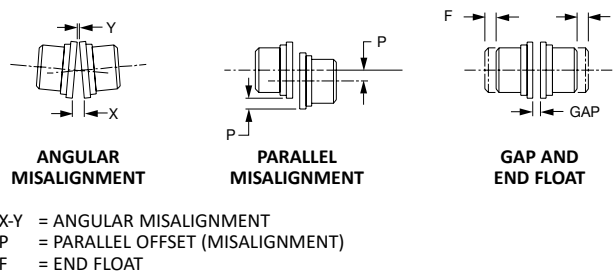

indicator may be used to more accurately take the measurements described above.

Special adjustments may need to be made for couplings used with some equipment. As an example, when used with motors of over 300 HP, couplings may require provisions for limiting end float. Larger drivers may grow in operation (due to heat expansion) requiring the driver side to be set slightly low when not operating. Specific instruction manuals or assembly drawings will indicate these requirements when applicable.

Thoroughly clean the coupling halves after completion of alignment. Reassemble the coupling and tighten bolts, washers and locknuts. Lubricate per manufacturer’s recommendations.

Duct Connections

The fan support structure is normally not designed to carry loads imposed by the weight of ducts, silencers, stacks, etc. Supporting these loads on the fan can cause housing distortion and may cause performance problems due to the relation of fan housing to impeller. Use of flexible connections is recommended.

Where hazardous materials will be conveyed in the fan, all connections made by the user shall be completely sealed with material suitable for the gas or vapor to be handled.

Guards and Enclosures

When advised of the need for guards fully complying with the machinery directive, Twin City Fan Companies, Ltd. will supply the guarding identified as being required. In most cases, Twin City Fan Companies, Ltd. is not aware of the end use and installation of the fan, which typically eliminates the need for more restrictive guarding to be compliant with EN 294 and EN 811. For this reason, the user is must verify that the final installation is compliant with EN 953, EN 294 and EN 811. This is especially true of plug and plenum fans. Specific items that should be considered include but are not limited to the following:

- *Outlet ducting / enclosure.* The ducting or enclosure must be compliant to the requirements of EN 953 and EN 294 and EN 811. This is not assured by Twin City Fan Companies, Ltd. unless specifically notified by the end user at the time of the order.

- *Inlet guards.* Inlet guarding relies on the additional safety distance provided by inlet ducting or other enclosure increasing the safety distance to 850 mm or greater. This is because the installation usually eliminates the need for excessive guarding on the inlet of the fan. In addition, excessive guarding on the inlet of the fan would significantly deteriorate performance and is therefore not desirable.
- *Plug and Plenum fans.* These fans are intended for installation in a user supplied enclosure. Twin City Fan Companies, Ltd. rarely knows the details of the enclosure and therefore can not provide guarding based on the needs of the final installation for these types of fans. The user must verify that the enclosure a plug or plenum fan is located in is compliant with EN 953 and EN 294 and EN 811.



WARNING

Guards shall not be removed during fan operation as this could cause severe injury. Guards shall not be stood on or used to support any additional load.

Electrical Supply and Controls

Twin City Fan Companies, Ltd. does not supply electrical controls. Items identified below are intended to guide the user in supplying controls in conformance to Annex I of the Machinery Directive and EN 14461:2005 – Industrial Fans – Safety requirements. Furthermore, electrical installations shall fulfill the requirements of EN 60204-1 and shall be selected for compliance with the low voltage directive. Those involved with the design of the electrical supply and control systems should be familiar with the above mentioned standards and directives. Control systems including relays, contactors, Variable Frequency Drive Units, isolating transformers, over-current and short circuit protection devices may be required. Relays, contactors, Variable Frequency Drive Units, isolating transformers, over-current and short circuit protection devices should all be in compliance with the Low Voltage Directive. The following is a list of some of the more common European standards that are observed when considering compliance with the Low Voltage Directive.

- EN60742 - Isolating Transformers
- EN50178 - Electronic Equipment for use in Power Installations.
- EN60730-2-10 - Motor Starting Relays.
- EN60947-2-1 - Overload trips.
- EN60947-3-1 - Switches, Disconnectors, Switch Disconnectors and Fuse Combination Units.
- EN60947-4-1 - Electro-mechanical Contactors and Motor control circuits.
- EN60947-5-1 - Electromechanical control circuit devices.
- EN60947-5-5 - Low voltage switchgear and control gear - Part 5: Control circuit devices and switching elements - Electrical emergency stop devices with mechanical latching function.
- EN61810-1 - Electromechanical elementary relays - Part 1: General and requirements.
- EN60255-23 - Electrical relays - Part 23: Contact performance.
- EN60439-1 - Low Voltage Switchgear and Switchgear Assemblies, Part 1.
- EN 60034 - Rotating Electrical machines Parts 1 and 5.

Variable Frequency Drive Units come under the Low Voltage and EMC Directives. Standards that shall be considered for compliance with the EMC Directive are listed below:

- EN 61000-6-4: 2001 Generic Industrial Emission Standard.
- EN 55011: 1998 + A1 Conducted Emissions Industrial (Group 1 Class A)

In addition, controls shall meet the requirements for category 2 safety critical control systems as detailed in EN 954-1. When a VFD is used, controls shall be implemented to guard against the VFD causing the fan to run above the maximum safe speed of the fan.

Wiring diagrams provided by the electrical equipment manufacture shall be followed.

Electrical connection to fan grounding lugs must be made according to applicable national or local code.

General Considerations for Controls

Intended automatic or remote restart after short term power failure shall only be permitted if no risk exists and if there are no other fault conditions.

Warning signs that automatic or remote start may take place shall be provided when applicable.

After a stop caused by the safety devices indicating hazardous conditions, restart shall only be possible by an intentional operation of manual control.

When possible, electrical power cables connected to fans should be routed where there is least risk of personnel tripping, walking into or falling over such items because they have been routed in areas where personnel are expected to move.

If it is necessary for periodical inspection and repairs to override the monitoring and control systems during operation, then consideration shall be given to the provision of stand-by fans, motors or other features. This is allowed provided that:

- The alarm system remains in operation during the override and an alarm signal is given when the safety limits are reached.
- Override is indicated by a clearly visible signal.
- Override is affected by auxiliaries specially installed for that purpose, e.g. key operated switches.

MAINTENANCE

Any maintenance requiring the guards to be removed shall be performed while the fan is not operating. The rotor and all drive components that are free to move must be properly locked in place before obtaining access to those parts. When restarting fan after maintenance, follow operation checklist for start up of fan. Maintenance personnel should take the proper care to ensure that no items are left behind that could be drawn in and ejected from the fan. Anything dropped into the fan must be removed before starting.

Lockouts shall be used whenever unexpected energizing of the fan could cause a mechanical or electrical hazard.

Guards and Access Doors

Only personnel trained in the hazards and risks associated when installing, operating and maintaining fans shall be allowed to dismount ANY guards or access doors. Proper care should be taken so that no hardware is lost during maintenance. Fans are not to be operated without all of the guarding and original hardware and fixings properly in place.

Table 2a. Bearing Cap Bolt Torque Specifications

SHAFT DIA.	DODGE (USAF SERIES)			SKF (SAF SERIES)			LINK-BELT (PLB6800 SERIES)			SEALMASTER (RPB & RPB-M SERIES)				
	MODEL	TORQUE SAE GRADE 5 (FT-LBS)	TORQUE SAE GRADE 5 (N-m)	MODEL	TORQUE METRIC GRADE 8.8 CAP BOLTS (FT-LBS)	TORQUE METRIC GRADE 8.8 CAP BOLTS (N-m)	TORQUE SAE GRADE 8 CAP BOLTS (FT-LBS)	TORQUE SAE GRADE 8 CAP BOLTS (N-m)	MODEL	TORQUE (FT-LBS)	TORQUE (N-m)	MODEL	TORQUE (FT-LBS)	TORQUE (N-m)
35mm	-	-	-	-	-	-	-	-	-	-	-	PRB-35M	31	42
1.438"	509	24-30	32-40	SAF22509	45	61	70	94	PLB6823	45-50*	61-67*	RPB-107	31	42
40mm	-	-	-	-	-	-	-	-	PLB68M40	45-50*	61-67*	RPB-40M	31	42
1.688"	-	-	-	SAF22510	45	61	70	94	PLB6827	45-50*	61-67*	RPB-111	31	42
45mm	-	-	-	-	-	-	-	-	PLB68M45	45-50*	61-67*	RPB-45M	31	42
1.938"	-	-	-	SAF22511	60	81	110	149	PLB6831	45-50*	61-67*	RPB-115	31	42
50mm	-	-	-	-	-	-	-	-	PLB68M50	45-50*	61-67*	RPB-50M	31	42
55mm	-	-	-	-	-	-	-	-	-	-	-	RPB-55M	31	42
2.188"	513	40-50	54-67	SAF22513	60	81	110	149	PLB6835	45-50*	61-67*	RPB-203	31	42
60mm	-	-	-	-	-	-	-	-	PLB68M60	45-50*	61-67*	RPB-60M	75	101
2.438"	515	60-75	81-101	SAF22515	60	81	110	149	PLB6839	45-50*	61-67*	RPB-207	75	101
65mm	-	-	-	-	-	-	-	-	PLB68M65	45-50*	61-67*	RPB-65M	75	101
2.688"	516	120-150	162-203	SAF22516	110	149	220	298	PLB6843	90-100*	122-135*	RPB-211	75	101
70mm	-	-	-	-	-	-	-	-	PLB68M70	90-100*	122-135*	RPB-70M	75	101
2.938"	517	120-150	162-203	SAF22517	110	149	220	298	PLB6847	90-100*	122-135*	RPB-215	75	101
75mm	-	-	-	-	-	-	-	-	PLB68M75	90-100*	122-135*	RPB-75M	75	101
80mm	-	-	-	-	-	-	-	-	PLB68M80	90-100*	122-135*	RPB-80M	266	360
85mm	-	-	-	-	-	-	-	-	PLB68M85	90-100*	122-135*	RPB-85M	266	360
3.438"	520	208-260	282-352	SAF22520	150	203	380	515	PLB6855	160-180*	217-244*	RPB-307	266	360
90mm	-	-	-	-	-	-	-	-	PLB68M90	160-180*	217-244*	RPB-90M	266	360
95mm	-	-	-	-	-	-	-	-	PLB68M95	160-180*	217-244*	RPB-95M	266	360
100mm	-	-	-	-	-	-	-	-	PLB68M100	160-180*	217-244*	PRPB-100M (fixed)	266	360
3.938"	522	208-260	282-352	SAF22522	150	203	380	515	PLB6863	160-180*	217-244*	PRPB-100M (exp)	150	203
105mm	-	-	-	-	-	-	-	-	PLB6863	160-180*	217-244*	RPB-315 (fixed)	266	360
110mm	-	-	-	-	-	-	-	-	-	-	-	RPB-315 (exp)	150	203
115mm	-	-	-	-	-	-	-	-	-	-	-	RPB-105M (fixed)	266	360
120mm	-	-	-	-	-	-	-	-	PLB68M110	160-180*	217-244*	RPB-105M (exp)	150	203
125mm	-	-	-	-	-	-	-	-	-	-	-	RPB-110M (fixed)	266	360
4.438"	526	320-430	433-583	SAF22526	295	399	900	1220	PLB6871	280-330*	379-447*	RPB-110M (exp)	150	203
115mm	-	-	-	-	-	-	-	-	-	-	-	RPB-407 (fixed)	266	360
120mm	-	-	-	-	-	-	-	-	PLB68M115	280-330*	379-447*	RPB-407 (exp)	150	203
125mm	-	-	-	-	-	-	-	-	-	-	-	RPB-115M (fixed)	266	360
4.938"	528	512-640	694-867	SAF22528	295	399	900	1220	PLB68M125	400-430*	542-583*	RPB-115M (exp)	150	203
135mm	-	-	-	-	-	-	-	-	-	-	-	RPB-120M (fixed)	394	534
5.438"	532	512-640	694-867	SAF22532	-	-	380	515	PLB6887	400-430*	542-583*	RPB-120M (exp)	266	360
140mm	-	-	-	-	-	-	-	-	PLB68M140	400-430*	542-583*	RPB-125M (fixed)	394	534
150mm	-	-	-	-	-	-	-	-	PLB68M150	400-430*	542-583*	RPB-125M (exp)	266	360
5.938"	534	512-640	694-867	SAF22534	-	-	380	515	PLB68M160	400-430*	542-583*	RPB-125M (fixed)	394	534
160mm	-	-	-	-	-	-	-	-	-	-	-	RPB-125M (exp)	266	360
6.438"	536	512-640	694-867	SAF22536	-	-	380	515	PLB68M170	630-700*	854-949*	RPB-415 (fixed)	394	534
170mm	-	-	-	-	-	-	-	-	-	-	-	RPB-415 (exp)	266	360
6.938"	538	896-1120	1214-1518	SAF22538	-	-	600	813	PLB68M170	630-700*	854-949*	-	-	-

* Lower torque values are for oil lubricated threads.

Table 2c. IP Set Scew Torque Specifications

INCH SHAFTS				SHAFT DIAMETER (INCHES)												
MANUFACTURER	BRG ID	UNITS	THRU-1	1	1-3/16	1-7/16	1-11/16	1-15/16	2-3/16	2-7/16	2-11/16	2-15/16	3-7/16	3-15/16	4-7/16	4-15/16
SEAL-MASTER	RP	IN-LB	28	66	66	126	126	228	228	228	-	-	-	-	-	-
		FT-LB	2.3	5.5	5.5	10.5	10.5	19	19	19	-	-	-	-	-	-
		N-m	3.1	7.5	7.5	14.2	14.2	26	26	26	-	-	-	-	-	-
SKF	SY	IN-LB	87	87	87	165	165	290	290	290	290	430	430	620	-	-
		FT-LB	7.2	7.2	7.2	14	14	24	24	24	24	35	35	51	-	-
		N-m	9.8	9.8	9.8	19	19	33	33	33	33	47	47	69	-	-
SEAL-MASTER	NP	IN-LB	-	66	66	126	126	228	228	228	348	348	348	-	-	-
		FT-LB	-	5.5	5.5	10.5	10.5	19	19	19	29	29	29	-	-	-
		N-m	-	7.5	7.5	14.2	14.2	26	26	26	39	39	39	-	-	-
SEAL-MASTER	MP	IN-LB	-	66	126	126	228	228	228	348	348	348	504	1104	-	-
		FT-LB	-	5.5	10.5	10.5	19	19	19	29	29	29	42	92	-	-
		N-m	-	7.5	14.2	14.2	26	26	26	39	39	39	57	125	-	-
SEAL-MASTER	MPD	IN-LB	-	66	126	126	228	228	348	348	504	504	504	1104	1104	-
		FT-LB	-	5.5	10.5	10.5	19	19	29	29	42	42	42	92	92	-
		N-m	-	7.5	14.2	14.2	26	26	39	39	57	57	57	125	125	-
SEAL-MASTER	EMP	IN-LB	-	66	66	126	126	228	228	228	348	348	348	-	-	-
		FT-LB	-	5.5	5.5	10.5	10.5	19	19	19	29	29	29	-	-	-
		N-m	-	7.5	7.5	14.2	14.2	26	26	26	39	39	39	-	-	-
SKF	SYR	IN-LB	-	-	-	251	251	251	251	620	620	620	620	1325	-	-
		FT-LB	-	-	-	21	21	21	21	51	51	51	51	110	-	-
		N-m	-	-	-	28	28	28	28	69	69	69	69	149	-	-
LINKBELT / REXNORD	PB224	IN-LB	-	185	185	325	325	325	460	680	680	680	680	1350	1350	1350
		FT-LB	-	15.4	15.4	27	27	27	38	57	57	57	57	113	113	113
		N-m	-	21	21	37	37	37	52	77	77	77	77	153	153	153
SEAL-MASTER	RPB	IN-LB	-	-	108	108	108	180	180	180	408	408	408	876	1440	1440
		FT-LB	-	-	9	9	9	15	15	15	34	34	34	73	120	120
		N-m	-	-	12.2	12.2	12.2	20	20	20	46	46	46	99	163	163
SEAL-MASTER	ERPB	IN-LB	-	-	-	-	-	-	-	180	408	408	408	876	-	1440
		FT-LB	-	-	-	-	-	-	-	15	34	34	34	73	-	120
		N-m	-	-	-	-	-	-	-	20	46	46	46	99	-	163
DODGE	SCAH	IN-LB	73	73	141	141	141	252	252	252	252	252	-	-	-	-
		FT-LB	6.1	6.1	11.8	11.8	11.8	21	21	21	21	21	-	-	-	-
		N-m	8.3	8.3	16.0	16.0	16.0	28	28	28	28	28	-	-	-	-
DODGE	SCMAH	IN-LB	-	73	141	141	252	252	252	252	252	252	252	-	-	-
		FT-LB	-	6.1	11.8	11.8	21	21	21	21	21	21	21	-	-	-
		N-m	-	8.3	16.0	16.0	28	28	28	28	28	28	28	-	-	-
DODGE	S2000	IN-LB	-	-	165	165	165	290	290	290	620	620	620	1325	1325	1325
		FT-LB	-	-	13.8	13.8	13.8	24	24	24	52	52	52	110	110	110
		N-m	-	-	19	19	19	33	33	33	71	71	71	149	149	149
SKF	SYM	IN-LB	-	-	-	165	290	290	290	290	-	-	-	-	-	-
		FT-LB	-	-	-	13.8	24	24	24	24	-	-	-	-	-	-
		N-m	-	-	-	19	33	33	33	33	-	-	-	-	-	-
BROWN-ING	VPS 200	IN-LB	28	66	66	126	126	228	228	228	-	-	-	-	-	-
		FT-LB	2.3	5.5	5.5	10.5	10.5	19	19	19	-	-	-	-	-	-
		N-m	3.1	7.5	7.5	14.2	14.2	26	26	26	-	-	-	-	-	-
BROWN-ING	VP3 300	IN-LB	66	66	126	126	228	228	228	348	348	348	504	1104	-	-
		FT-LB	5.5	5.5	10.5	10.5	19	19	19	29	29	29	42	92	-	-
		N-m	7.5	7.5	14.2	14.2	26	26	26	39	39	39	57	125	-	-

Motor Maintenance

The three basic rules of motor maintenance are:

1. Keep the motor clean.
2. Keep the motor dry.
3. Keep the motor properly lubricated.

Blow dust off periodically (with low pressure air) to prevent motor from overheating.

If the motor is to be started after sitting for more than a week, the resistance of the motor windings to earth should be measured (at 500 V DC). If the resistance is less than 10 megohms, the motor should be dried until a resistance over 10 megohms is measured.

Some smaller motors are lubricated for life. Lubrication requirements are normally attached to the motor. Use the motor manufacturer's recommendations for re-lubrication. If this information is not available, the following schedule may be used. Motors less than 10 HP running about eight hours a day in a clean environment should be lubricated once every five years; motors 15 to 40 HP, every three years. For motors in dusty or dirty environments or running 24 hours a day: divide the service interval by 4. Do not over lubricate. Note that motors typically use a different type of lubricant than fan shaft bearings.

Drive Maintenance

V-belt drives need periodic inspection, re-tensioning and occasional belt replacement. Follow Table 5 on page 11 for drive inspections and maintenance. Proper belt tension can be found on the included datasheet specific to each fan. A log should be kept with belt tension and replacement information.

Bearing Maintenance

Proper lubrication of the fan drive bearings helps assure maximum bearing life. All fans are equipped with decals indicating re-lubrication intervals for normal operating conditions. Bearings should be inspected after the first 24 hours of operation and then inspected each time they are lubricated. Lubrication schedules for the included type of bearings are attached to the fan. Note that all speeds shown do not apply to all shaft sizes in that group. Consult the factory if in doubt of maximum speed for a particular bearing. Note that every installation is different and the frequency of re-lubrication should be adjusted accordingly.

On high moisture applications the lubrication frequency may need to be doubled or tripled to adequately protect the bearings. Double the relubrication frequency on fans with vertical shafts.

Observation of the conditions of the grease expelled from the bearings at the time of relubrication is the best guide as to whether regreasing intervals and amount of grease added should be altered.

Greases are made with different bases. There are synthetic base greases, lithium base, sodium base, etc. Avoid mixing greases with different bases. They could be incompatible and result in rapid deterioration or breakdown of the grease. The lubrication sticker identifies a list of acceptable lubricants. All fan shaft bearings are filled with a lithium-based grease before leaving the factory unless otherwise specified. When the fans are started, the bearings may discharge excess grease through the seals for a short period of time. Do not replace the initial discharge because leakage will cease when the excess grease has worked out. Sometimes the bearings have a tendency to run hotter during this period. This is no reason for alarm unless it lasts over 48 hours or gets very hot (over 200°F, 93°C).

If bearings are exhibiting excessive vibration at any time or are running hotter than 200°F, 93°C, the bearings should be inspected for proper lubrication, alignment, tightness of set screws, cap bolts and collars, and inspected for signs of contamination in the lubricant. The bearings or damaged bearing components

shall be replaced if found faulty or showing signs of wear. When relubricating, use a sufficient amount of grease to purge the seals. Rotate bearings by hand during relubrication.

Impeller and Shaft Maintenance

Inspect the shaft and impeller for dirt build-up, corrosion, and signs of excess stress or fatigue after one month of service. Future inspection interval shall be based on findings in this initial inspection. Clean the components. If any signs of damage, stress or fatigue are present (deformation, cracks, excessively worn surfaces) the part shall be replaced. Any material buildup on rotating parts or parts that could contact rotating parts shall be cleaned. If the impeller is removed for any reason, make sure that it is securely attached to the shaft before restarting the fan. The impeller and shaft shall also be inspected any time excessive vibration is observed (filter in readings should be 7.2 mm/s RMS or less). Reference ISO 14694:2003, "Industrial Fans – Specifications for Balance Quality and Vibration Levels" for more details on acceptable fan vibration levels.

Structural Maintenance

All structural components or devices used to support or attach the fan to a structure should be checked at regular intervals. Vibration isolators, bolts, foundations, etc., are all subject to failure from corrosion, erosion and other causes. Improper mounting can lead to poor operation characteristics or fan fatigue and failure. Check metallic components for corrosion, cracks or other signs of stress. Replace any components showing any of these signs. Concrete should be checked to insure the structural integrity of the foundation and repaired or replaced if any signs of damage are found.

Where the fan is used to handle toxic gasses or vapors, the housing, and welds shall be inspected for signs of corrosion or cracking at regular intervals to assure no toxic gasses can escape. The condition of the coating shall be inspected as well to verify that bare parts of the fan are not exposed. All gaskets and ducting shall be inspected for signs of erosion as well. An initial inspection after one month of service shall be used to determine an appropriate inspection interval.

FAN OPERATION

Proper Use and Application

It is critical that fans are operated only as their design intended. Standard construction is designed for standard applications as defined below:

- Clean air – no solids, particles or corrosive or abrasive gasses.
- Air stream temperatures between 120°F (49°C) and -20°F (-29°C) with a maximum temperature fluctuation of 15°F (8°C) per minute.
- Ambient temperatures shall not exceed 104°F (40°C) for standard design fans.
- Constant speed operation.

Operating a fan in any of the following conditions could cause a safety hazard:

- Do not operate a fan in an environment that it was not designed for. This includes operating the fan in temperatures or with abrasive or corrosive vapors or chemicals or solid material (including fly ash) other than the fan was designed for. Operating at elevated temperatures or with abrasive or corrosive vapors requires special considerations that must be incorporated in the design, material selection, coating and maintenance of the fan.

- Do not operate a fan at a higher speed than the fan, drives, seals, bearings or other components were designed for.
- Do not use variable rotational speed service without first consulting Twin City Fan Companies, Ltd.
- Do not operate a fan without the bearings and couplings properly lubricated. Lubrication intervals are explained in corresponding maintenance sections of this manual.
- Do not operate a fan exhibiting increased vibration levels. Filter in readings should be 7.2 mm/s RMS or less.
- Do not operate the fan in stall.
- Do not operate the fan with replacement or added components that are not recommended by Twin City Fan Companies, Ltd. The use of insufficient components could cause premature wear and failure.

All of the above conditions could lead to mechanical failure causing safety hazards including exposure to ejected objects and toxic material or vapors.

For high temperature applications, it is recommended that an auxiliary device be provided (such as a turning gear available from Twin City Fan Companies, Ltd.) to slowly rotate the fan when it is

not operating while exposed to high temperatures. Exposure to high temperatures while not operating could be due to a power failure or standard operation of a process.

When multiple fans are installed for redundancy, the fan used shall be switched at least weekly to avoid the need for storage considerations.

Sound

Sound power levels are supplied with each fan. These levels are based on AMCA 300 reverberant room test methods. This method is similar to ISO 3741. Field installation and conditions can affect sound greatly. Because of this, the user shall verify if the sound pressure levels in the installed condition are below 70 dBA. If sound pressure levels are above 70 dBA, actions shall be taken to reduce sound pressure levels to acceptable levels.



Table 5. Drive Maintenance and Inspection

TYPE OF MAINTENANCE	WHEN TO DO	WHAT TO DO
Check for sheave groove wear	Initial inspection: 8 hours. Second inspection: 24 hours. Third inspection: 100 hours. Periodically thereafter.*	Check for belt ride in the groove. In multiple groove drives, belt ride should be uniform, not more than 1/16" above or below top of sheave groove. Check groove wear area for wear. Side wall of groove should be straight, not dished out. Bottom of groove should show no signs of belt contact.
Check for sheave runout.	Initial inspection: 8 hours. Second inspection: 24 hours. Third inspection: 100 hours. Periodically thereafter.*	Check sheave by eye for runout. If runout is excessive, it can easily be seen by visual inspection. If runout is noticeable, check sheave for source of problem and correct.
Inspect for heat build-up and proper ventilation	Initial inspection: 8 hours. Second inspection: 24 hours. Third inspection: 100 hours. Periodically thereafter.*	Check bolts for heat. Ambient temperature should not exceed 140°F. Contact temperatures should not exceed 180°F. Make sure drives are properly ventilated.
Clean belts and sheave grooves	Initial inspection: 8 hours. Second inspection: 24 hours. Third inspection: 100 hours. Periodically thereafter.*	Inspect belts for contaminates, such as oil or grease. Wipe belts clean with detergent and water. Inspect sheave grooves for build-up of such material and remove, if necessary.
Check belt tension	Initial inspection: 8 hours. Second inspection: 24 hours. Third inspection: 100 hours. Periodically thereafter.*	Check belt tension using BROWNING belt tension checker. Tension to recommendations shown in current catalogs.
Check sheave alignment	Initial inspection: 8 hours. Second inspection: 24 hours. Third inspection: 100 hours. Periodically thereafter.*	Check alignment with straight edge, string or machinist level. Correct alignment to as near perfect as possible.
Mismatched belt check	Initial inspection: 8 hours. Second inspection: 24 hours. Third inspection: 100 hours. Periodically thereafter.*	Check belt sag on slack side of drive. All belts should have a slight bow. If this bow is not uniform with all belts, replace entire set with a matched set.
Check for worn belts	Initial inspection: 8 hours. Second inspection: 24 hours. Third inspection: 100 hours. Periodically thereafter.*	Check wear surfaces for belt for excessive wear. If belts have a slick, glazed look, belts are lipping. Check drive capacity and belt tension. Never replace only one belt in a used set, as used belts will elongate. Replace entire set if replacement is necessary.
Check sheave set screws and/or busing cap screws	Initial inspection: 8 hours. Second inspection: 24 hours. Third inspection: 100 hours. Periodically thereafter.*	Check all set screws and/or busing cap screws for looseness. Retighten to recommended torque, if necessary.

* Inspections listed as "periodically" must be performed at least monthly for ATEX fans.

The following EN standards can be referred to as a guide when making noise measurements:

- EN 809 EN ISO 5136:2003 - Acoustics - Determination of sound power radiated into a duct by fans and other air-moving devices - In-duct method.
- EN ISO 11200/A1 1997 - Noise emitted by machinery and equipment - Guidelines for the use of basic standards for the determination of sound pressure levels at a workstation and at other specified positions.
- EN ISO 11202/A1 1997 - Noise emitted by machinery and equipment - Measurement of emission sound pressure levels at a workstation and at other specified positions – Survey method in situ.

Operation Checklist

WARNING

Verify that proper safety precautions have been followed. Electrical power must be locked off.

Check fan mechanism components:

- Nuts, bolts, set screws are tight per Tables 1 - 4.
- Mounting connections are properly made and tightened.
- Bearings are properly lubricated.
- Impeller, drives and fan surfaces are clean and tightened.
- Rotating assembly turns freely and does not rub.
- Drives on correct shafts, properly aligned and properly tensioned.
- Check that no foreign objects are in the fan or ductwork.

Check fan electrical components:

- Motor is wired for proper supply voltage.
- Motor was properly sized for power of rotating assembly.
- Motor is properly grounded.
- All leads are properly insulated.
- Resistance between motor windings and earth is over 10 megohms (see motor maintenance section).
- Control equipment is functioning properly.

Trial “bump”:

- Turn on power just long enough to start assembly rotating.
- Check rotation for agreement with rotation arrow
- Listen for any unusual noise.

Run unit up to speed:

- Bearing temperatures are acceptable (<200°F, 93°C) after one to two hours of operation.
- Check for excess levels of vibration. Filter in readings should be 7.2 mm/s RMS or less.
- Check that motor current draw is not above the nameplate value.

After one week of operation:

- Check all nuts, bolts and set screws and tighten if necessary.
- Readjust drive tension if necessary. (See Table 5 for drive maintenance schedule.)

Optional Accessories

1. **Turning Gear** — A turning gear is sometimes used in high temperature applications where the fan is exposed to high temperature gases while not operating. The impeller and shaft can expand unevenly due to the temperature when sitting idle, which can cause vibration at startup and/or a permanent set to the rotor. The turning gear slowly turns the fan from the outboard side while it is not operating, providing for even thermal expansion. It starts automatically when the fan shuts down and disengages automatically when the fan starts up again. More specific information will be provided for each application.
2. **Shaft Seals** — The standard shaft seal is a ceramic fiber element retained with an aluminum retaining plate and clips. Other configurations of shaft seals are available for special applications, such as when it is necessary to keep the shaft seal as gas tight as possible. Shaft seal application manuals are provided in Engineering Supplement ES-5-95.
3. **Variable Inlet Vanes** — Variable inlet vanes are provided as assemblies internally in the inlet cone or externally in a flanged cylinder. The vanes are used to control volume and save power in installations where different volumetric operating conditions are used. Installation manuals are provided in other engineering supplements for specific fan types. Variable inlet vanes may be provided with powered operators in which case the manufacturer’s installation and operating manuals will be provided.
4. **Inlet Box and Inlet Box Dampers** — Inlet boxes may be provided to allow transition from a duct to the fan inlet. Inlet box dampers may also be provided for volumetric regulation similar to inlet vanes. Dampers are usually provided as a complete assembly and are installed with the damper axles parallel to the fan shaft. They should be installed to pre-spin the air in the direction of fan rotation. See Figure 7.

Figure 7. Orientation of Damper Blades As Related to Fan Rotation

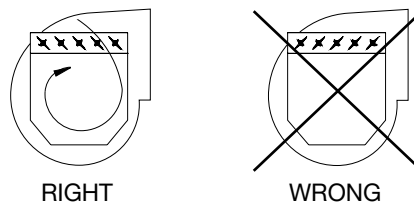

5. **Outlet Dampers** — Outlet dampers are usually provided completely assembled like the inlet dampers. The damper is bolted to the fan discharge for volume control.
6. **Shaft Cooler** — Also referred to as “heat slingers” or “cooling wheels,” these are small, radially bladed aluminum impellers that are split and bolted for installation between the inboard bearing and fan housing. The back plate usually is closest to the fan housing and the blades face the bearing. Specific instructions will be provided by application.
7. **Oil Circulating Systems** — Usually the following modifications will have to be made to the bearing if an oil circulating system is used. When an oil circulating system is included, a manual for its installation, operation and maintenance will accompany it.
 - a. Four drain holes will be drilled in the bearing, two on each side of the bearing. Because of this, the bearing may be drained from either side. (Drain from both holes on one side of the bearing.)
 - b. It is not necessary to drain the bearing.

- c. The bearing will be packed with grease to prevent corrosion until installed and started up. The drain holes will be plugged with plastic covers to make sure they are open.

NOTICE

The customer **MUST REMOVE** most of the grease using solvent and remove the plastic covers prior to starting the oil circulating system.

- d. A wet sump will be added in case of circulating oil pump failure. Seals will be provided to accommodate the resultant splashing.
- e. The zerk on top of the bearing will be removed for that hole to be used as the oil inlet.

Troubleshooting Guidelines

Use current safety practices when investigating fan or system performance problems. General safe practices and performance troubleshooting guidelines can be found in AMCA Publications 410 and 202, respectively. Fan application and field measurement procedures can be found in AMCA Publications 201 and 203.

Below is a list of possible areas to check when air or sound values do not match expectations. Most fan problems can be pinpointed to one of these common causes.

Air Capacity Problems

1. Resistance of the system is not at design rating. If resistance is lower than expected, both airflow and horsepower may be up. If resistance is higher than anticipated, air volume will be down.
2. Fan speed is not at design speed.
3. Air density is not at the design value. Also check air performance measurement techniques/procedures.
4. Devices for air modulation are closed or plugged. Also check filters.
5. Impeller mounted improperly or is rotating in reverse.
6. Parts of the system or fan have been damaged or need cleaning.

Noise Problems

1. Air performance is incorrect and the fan is not at design point of operation. Fan is being forced to operate in an unstable flow region.
2. Bearing failure. Check bearings (lubrication).
3. Supply voltage high or inconsistent supply frequency. Adjustable frequency controllers can generate motor noise.

4. Objects that are installed in a high velocity airstream can generate noise. This includes flow sensors, turning vanes, etc.
5. Poor fan inlet conditions.
6. Acoustics or sound measurement procedure incorrect.

Vibration Problems

1. Misalignment of drive components.
2. Poor foundation or mounting structure (resonances).
3. Foreign material attached to rotating components.
4. Damaged rotating components (bearings, shaft, fan, impeller, sheaves).
5. Broken, loose or missing set screws.
6. Loose bolts.
7. Vibration transmitted by another source.
8. Water accumulating in airfoil blades.
9. Fan is operating in stall or unstable flow region.

Motor Problems

1. Incorrect wiring.
2. Speed of fan too high.
3. Parts improperly installed; binding.
4. Bearings improperly lubricated.
5. WR^2 capability of motor too low for application.
6. Protection devices may be improperly sized.

Drive Problems

1. Belts improperly tensioned.
2. Drive alignment is poor.

Disassembly/Disposal

After the expiration of the service life of the fan or its parts and during subsequent disposal of the unit, applicable local regulations shall be observed. For the disposal of the fan or its components, it is necessary that the fan be safely disconnected from the electrical power supply. The disassembly (removal) of the fan shall follow the reverse sequence of the assembly/installation procedure. All safety measures still apply; especially in terms of lifting and transportation of removed components.

Materials used in the fan and methods of their disposal:

- a. Ferrous and non-ferrous metals - by scrapping
- b. Lubricants, seals and electrical material - by an accredited organization
- c. Others - follow local regulations

APPENDIX A – COMMERCIAL VENTILATOR INSTALLATION INSTRUCTIONS

Handling

Roof ventilators should be lifted by using straps around the fan housing or base only. Spreader bars should also be used to avoid damage to stack caps or hoods. **DO NOT LIFT ROOF VENTILATORS BY THE STACK CAP OR HOOD.** On hooded units, disassemble the stack from hood when lifting. Upblast models may be lifted assembled.

Installation Instructions – Follow the above section titled “Fan Installation, Factory Assembled Units” with the exception of the instructions below for commercial ventilators.

Roof ventilators should always be mounted to a flat, level, solid and rigid structure. Particular caution should be exercised when installing fans on metal buildings. Be sure wall or roof is capable of supporting the fan(s).



CAUTION

Fans mounted on walls or roofs and not supported correctly will cause vibration that could cause damage or injury.

Fans mounted off ground level should be rigidly mounted to a structural platform and be placed over or as near as possible to a solid wall or column.

Support for suspended fans must be cross-braced for live load support to prevent side sway. Use guy wires to help secure roof units if excessively windy conditions prevail.

APPENDIX A – COMMERCIAL VENTILATOR INSTALLATION INSTRUCTIONS (CONT'D)

Figure 8. Mounting Roof Ventilator to Curb Cap

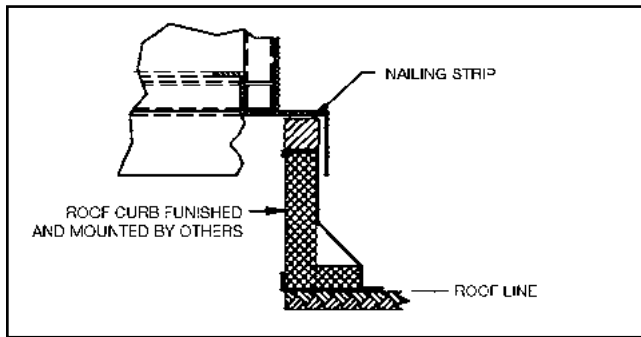

When the roof ventilator is designed to be mounted on a curb, the curb should be securely installed prior to the fan installation.

A damper, if used, should be securely mounted within the curb or wall in a manner that allows free and unobstructed operation.

On roof units, anchor the fan securely to the curb. Anchoring through the vertical portion of the curb cap flange is recommended. Use a minimum of four lag bolts or other suitable fasteners. See Figure 8.

Hooded Ventilators

Hooded units sizes 12 to 42 use a one-piece hinged hood. To lift the hood, remove the two bolts located under the mushroom cap and prop the hood up with the supplied safety rods. Push and lock into place. A screw is installed at the end of the pin side of the hinge in the hood angle to prevent accidental removal of the hood. To close

the hood, replace the bolts to lock in place. For size 48, a one-piece bolted hood connects directly to the fan stack. To lift the hood off the unit, remove the bolts located under the mushroom cap. For sizes 54–72, a two-piece bolted hood connects directly to the fan stack. To lift the hood off the unit, remove the sheet metal bolts that connect the right and left sides of the hood and then remove the bolts located under the mushroom cap. See Figure 9.

Figure 9. Typical Hooded Roof Ventilator Installations

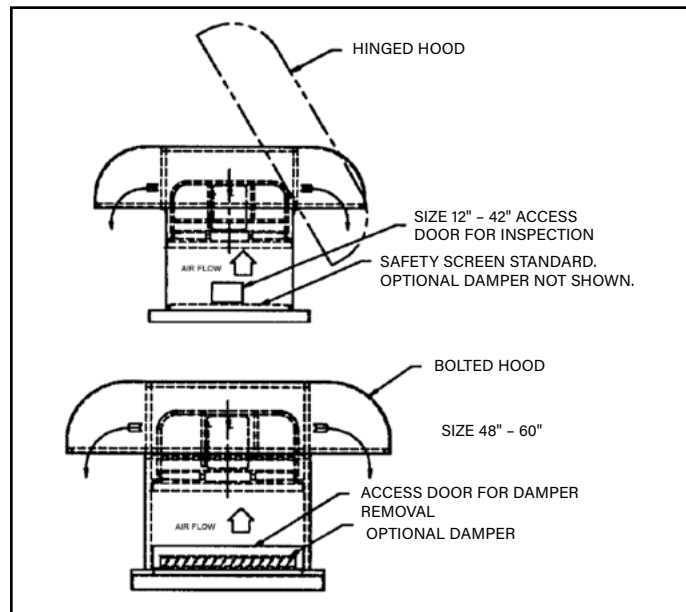

APPENDIX B – AXIAL FANS

Axial Fans - Securing the Impeller to the Shaft

If the impeller is removed for any reason, make sure that it is securely attached to the shaft before restarting the fan. If the impeller is attached to the shaft by means of a Trantorque bushing, use the tightening torque values shown in Table 6 below. For other bushings, see table 3 for proper torque values.

Table 6. Trantorque Bushing Torque Values

Trantorque Size	Shaft Diameter	Socket Size	Torque	
			Ft-Lb	N-m
7/8	7/8	1-1/2	71	96
1-1/8	1-1/8	1-3/4	130	176
1-3/8	1-3/8	2	141	191
1-5/8	1-5/8	2-1/4	233	316
1-7/8	1-7/8	2-1/2	325	441
2-1/8	2-1/8	2-3/4	440	597
2-3/8	2-3/8	3	470	637
2-7/8	2-7/8	3-1/2	550	746

Note: These torque values are to be obtained with a calibrated torque wrench. DO NOT apply any lubricant to any part of the Trantorque® hub. DO NOT use an anaerobic thread adhesive such as Loctite® on the threads.

Axial Fans with Adjustable Blade Angles

The blades are set at the factory to the blade angle that gives the performance specified on the order. This angle should be checked prior to start-up. The blade angle should not be changed from that stated for the order without assuring that a change in blade angle will not overload the motor, any controls or other items. Vibration levels shall also be checked in accordance with ISO 14694:2003, "Industrial Fans – Specifications for Balance Quality and Vibration Levels" if any change is made to blade angles.

Blade Adjustment on Adjustable Pitch Vaneaxial Type VJ

The patented impeller construction uses friction and centrifugal force to hold the blades in place. No disassembly of the impeller is required to change the blade angles. If it is necessary to change the blade angle, the following procedure should be used:

1. Work safely. Make sure that proper safety precautions have been followed. Electrical power must be locked off.
2. The adjustment can be made through the inlet on open inlet fans. On fans with ducted inlets, open the impeller area access door.
3. Place adjustment tool around end of blade (see Figure 10). If necessary, apply "cheater bar" around the 1 1/4" (31.75mm) diameter end for additional leverage. The blades can be turned by hand on open inlet fans. If additional leverage is needed, place a wrench on the leading edge of the blade near the hub. Take care not to mar the surface of the blade.

Figure 10. VJ Blade Angle Adjustment

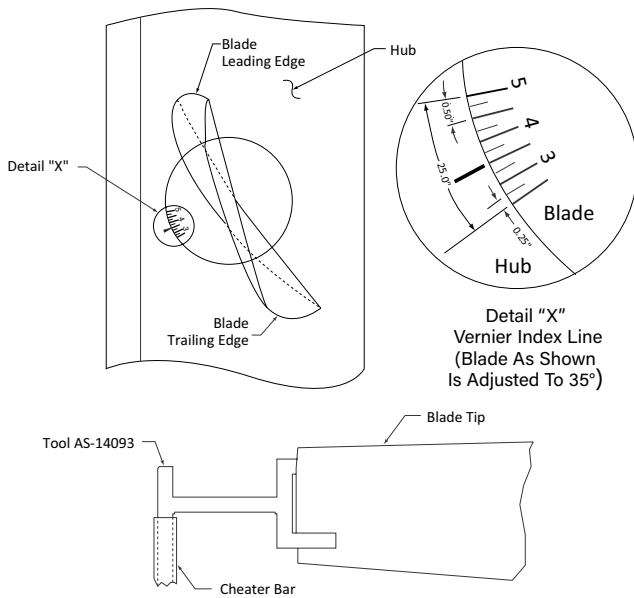

Blade Adjustment on Type "E" Adjustable Pitch Impeller Preferred Method (More Accurate)

1. Lay the hub on a horizontal surface with the concave (air leaving) surfaces of the blades facing upwards.
2. Loosen the blade retaining bolts until they are finger-tight. At this point, the blades should rotate in their sockets when grasped firmly and twisted, but not turn on their own.
3. Place an angle meter across the two blade angle position marks on a blade. See Figure 11.

Figure 11. Blade Position Marks

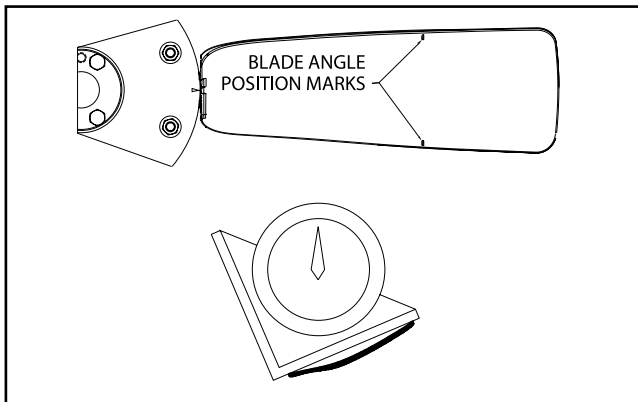

4. Twist the blade to the desired blade angle.
5. Repeat steps 3 and 4 for the remaining blades.
6. Re-tighten the blade retaining bolts to the torque shown in Table 7. Work in a star pattern, working your way up to the desired torque in steps. Tightening one bolt to the full torque before moving on to the next can crack the hub.

Alternate Method

1. Loosen the blade retaining bolts until they are finger-tight. At this point, the blades should rotate in their sockets when grasped firmly and twisted, but not turn on their own.
2. Angle setting marks on the blade line up with an indicating arrow on the hub. There are two long marks on the blade, one for 12° blade angle and another for 32°. Shorter indicating marks at 5° increments are in between the two longer marks. See Figure 12.
3. Twist each blade to the desired blade angle.

Table 7. "E" Prop Torque Specifications

Fan Size	Hub Size	Blade Bolt Torque	
		Ft - lb	N - m
14 - 24	6	17	23
30 - 36	9	30	41
42 - 48	12	75	102

See Table 3 for bushing bolt torques - Use aluminum hub values.

Figure 12. "E" Prop Blade Angle Indicating Marks

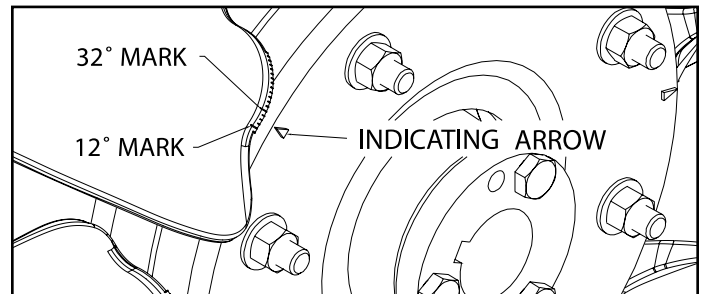

4. Re-tighten the blade retaining bolts to the torque shown in Table 7. Work in a star pattern, working your way up to the desired torque in steps. Tightening one bolt to the full torque before moving on to the next can crack the hub.

Blade Adjustment on Axial Adjustable Pitch Impeller

Each blade has cast into it a number of raised marks with grooves in between and the fairing has a register mark machined into it at each blade opening. See Figure 13, which identifies each of the ridges and grooves with a number from 0 to 9. These numbers correspond to the performance curve numbers shown in the AXIAD II design performance manual.

Figure 13. Axial Blade Angle Indicators

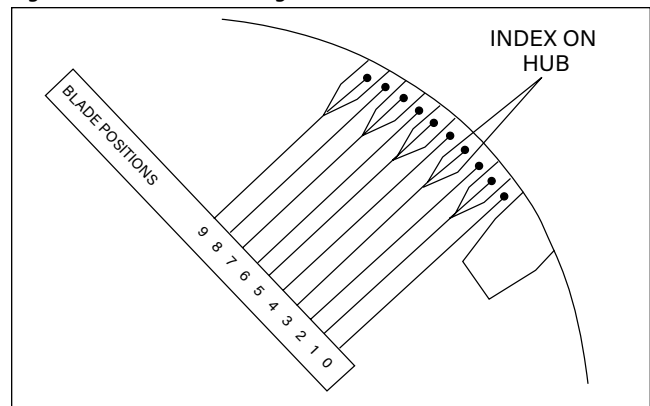

On Arrangement 4 Type 3 Axial fans, the blade angle can be adjusted by removing the inlet screen. On ducted fans, the case is provided with an 8-inch square door in the fan tube. To set the blade pitch, proceed as follows:

NOTE: A 5/16" key with a square drive adaptor fitted to a torque wrench is required. In most cases, a universal joint will also be needed.

1. After access has been obtained to the rotor, loosen the two blade bolts until the blade is free to rotate.
2. Rotate the blade to line up the register mark on the fairing with the desired blade angle mark on the blade.

 **CAUTION**

Do not exceed blade position 9.

- Tighten the two bolts evenly until a torque level of 65 ft-lb (88 N-m) is reached.

CAUTION

It is important that the blade bolts are torqued to the specified value. Do not hand-tighten the bolts.

- Repeat steps 1 through 3 for all blades. Make sure all blades are set at the same mark.
- After all blades are set at a new angle, run the fan for a few minutes and then re-torque all blade bolts.

Blade Adjustment on Reversible Adjustable Pitch Impeller

Assembly Procedures

- Lay hub on a horizontal surface with openings of shank sockets (Figure 15) facing up. This is normally the discharge side of the assembly.
- Lay blade shank in socket with discharge side of the blade up. The discharge side of the blade is the side with the angle setting mark. Line up the index mark on the blade with the proper angle mark on the end of the shank socket (Figures 14 and 15) on the underside of assembly.
- Place cap over blade shank with beveled end toward center. Install U-bolts and elastic nut stops. Before tightening lock nuts, pull the blade outward to set the key against the keyway and check angle setting (Figures 14 and 15).
- Tighten elastic stop nuts evenly and torque to the following foot-pounds:
- Check angle setting to be sure it has not changed during assembly. If so, loosen lock nuts and reset angle. Tighten nuts again to proper torque. Do not over-tighten. Be sure to tighten U-bolts evenly.

Figure 14. Angle Setting Markings

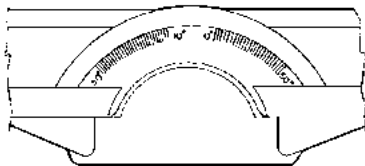

Angle setting index on shank socket. Marked from 10° through 50°. Each mark is 2°.

Table 8. U-Bolt Torque for Blades

Prop Size	Hub Size	U-Bolt Size	Torque			
			Aluminum		Fiberglass	
			Ft-lb	N-m	Ft-lb	N-m
54 - 72	14	1/2"	20	27	30	41
81 - 96	18	3/4"	45	61	50	68
108 - 144	18	3/4"	45	61	50	68

Figure 15. Assembly Exploded View

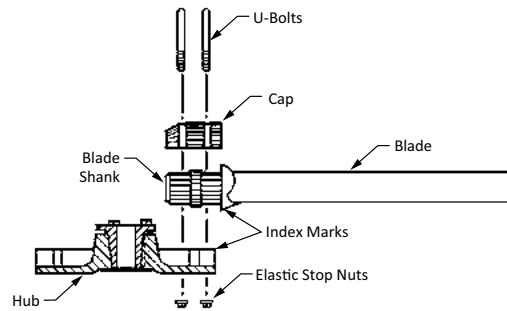

Setting Angle with Protractor (optional)

Under most conditions, the preceding assembly procedure using the index marks is of sufficient accuracy.

When greater accuracy is desired, use a level bubble protractor. Before the final tightening of the nuts, set the protractor on the angle setting mark. (The hub and blade assembly must be level for accurate setting.)

Adjust the angle by tapping the shank end with a mallet.

Figure 16. Blades and Angle Setting Mark

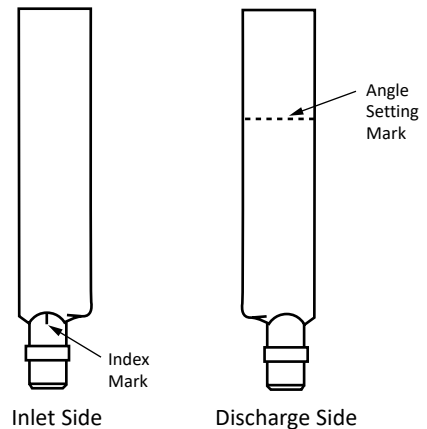

Tighten lock nuts to proper torque per Table 8. Again check the angle setting. Rotate impeller to check angle on each blade in the same location.

Impellers may be assembled so the cap side of the hub is the inlet side (reverse bore). If blades do not have the index mark on the discharge side, it is then necessary to adjust the blade angle with a protractor.

The hub and blades are balanced separately. The weight distribution throughout the length of the blade varies slightly. Therefore, the balance is to a constant moment and blades may be assembled at random even though the weights are slightly different.



WWW.AEROVENT.COM

5959 TRENTON LANE N | MINNEAPOLIS, MN 55442 | PHONE: 763-551-7500 | FAX: 763-551-7501

© 2006-2023 TWIN CITY FAN COMPANIES, LTD.