

General Installation, Operation and Maintenance Instructions For Aerovent Products

AVAILABLE VANEAXIAL FAN DESIGNS

BELT DRIVEN – TYPE B AND P

The Type B and P belt driven vaneaxial fan designs incorporate internal guide vanes welded around the inner shell bearing support. An impeller inspection section to facilitate cleaning the cast solid aluminum impeller can be provided as an option. If this section is not furnished it is necessary to field install an access door in the duct next to the inlet or to remove the fan from the duct system for cleaning of the impeller and guide vanes. For high temperature or corrosive applications, the Type B can be reconfigured with an external guide vane section similar to the Type T shown below.

DIRECT DRIVE – TYPE B AND P

The Type B and P direct drive vaneaxial fan designs incorporate internal guide vanes welded around a circular bulkhead/motor base plate assembly. An impeller inspection section to facilitate cleaning the cast solid aluminum impeller can be provided as an option. If this section is not provided it is necessary to field install an access door in the duct next to the fan inlet or to remove the fan from the duct system for cleaning of the impeller and guide vanes.

BELT DRIVEN – TYPE W & J

The Type W belt driven vaneaxial fan design incorporates internal guide vanes welded around the inner shell bearing support. For Type W, an impeller inspection section to facilitate cleaning the adjustable pitch aluminum impeller can be provided as an option. If this section is not furnished it is necessary to field install an access door in the duct next to the fan inlet or to remove the fan from the duct system for cleaning of the impeller and guide vanes. For Type J, an impeller access door is provided as standard.

DIRECT DRIVE – TYPE W & J

The Type W direct drive vaneaxial fan design incorporates internal guide vanes welded around the circular bulkhead/motor base plate assembly. For Type W, an impeller inspection section to facilitate cleaning the adjustable pitch aluminum impeller can be provided as an option. If this section is not furnished it is necessary to field install an access door in the duct next to the fan inlet or to remove the fan from the duct system for cleaning of the impeller and guide vanes. For Type J, an impeller access door is provided as standard.

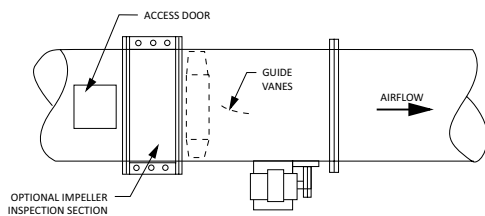

Type B, W, J & P Belt Driven Vaneaxial Fan

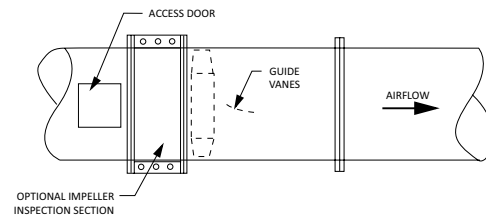

Type B, W, J & P Direct Drive Vaneaxial Fan

BELT DRIVEN – TYPE S

The Type S belt driven vaneaxial fan design incorporates internal guide vanes welded around the inner shell bearing support. An access door over the impeller area can facilitate inspection of the welded steel impeller and can be provided as an option. If impeller cleaning capability is desired, it is necessary to field install an access door in the duct next to the inlet or to remove the fan from the duct system for cleaning of the impeller and guide vanes.

BELT DRIVEN – TYPE T

The guide vanes are built into a removable section of duct adjacent to the impeller and can be taken completely out for cleaning without disturbing the fan. Removing the vane section also provides access to the cast solid aluminum impeller. The construction of this fan lends itself to high temperature or corrosive applications. As an alternative, an optional access door can be provided in the fan housing for inspection and cleaning of the impeller.

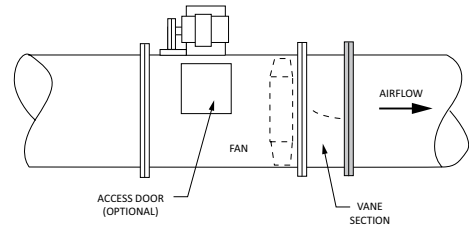

Type T Belt Driven & Type B High Temperature

TYPE W - ADJUSTABLE PITCH IMPELLER

The blade angle of the adjustable pitch Type W vaneaxial impeller has been set at the factory to deliver a particular performance. However, the performance of the fan can be changed by adjusting the blade to a different angle, either higher or lower, depending on the volume of air required. Blades may be adjusted for low angles without concern of overloading motors. When adjusting to higher angle settings, check motor current to be sure the motor is not overloaded. Keep motor current within nameplate and service factor ratings. See Catalog 456 for Type W vaneaxial fan performance data.

The blades are held in place by a high strength specially designed steel bolt cast into the blade and threaded into the hub. It is locked by one setscrew. There is a scale on the hub that indicates the position in degrees. An index mark needs to be made on the blade before adjusting.

To change the angle, simply loosen the setscrew with an Allen wrench, adjust the index mark on the blade to the proper angle setting on the scale on the hub and tighten. The angle cannot be thrown off once the locking setscrew is tightened. When increasing the angle, turn the impeller by hand to check tip clearance before startup.

Bushing Bolt Torque Values

BUSHING NO.	DIAMETER	LENGTH (IN.)	TORQUE FT. LBS.
H	1/4-20	1 1/4	7 1/2
P-1	5/16-18	1 1/2	13
P-2	5/16-18	1 3/4	13
Q-2	3/8-16	2 1/2	24
R-2	3/8-16	3	24

Setscrew Torque Values

SETSCREW SIZE	TORQUE (FT.-LB.)	
	SOCKET HEAD	SQUARE HEAD
5/16	14	18
3/8	16	24
1/2	34	45
5/8	64	85

W7 Adjustable Pitch Impeller

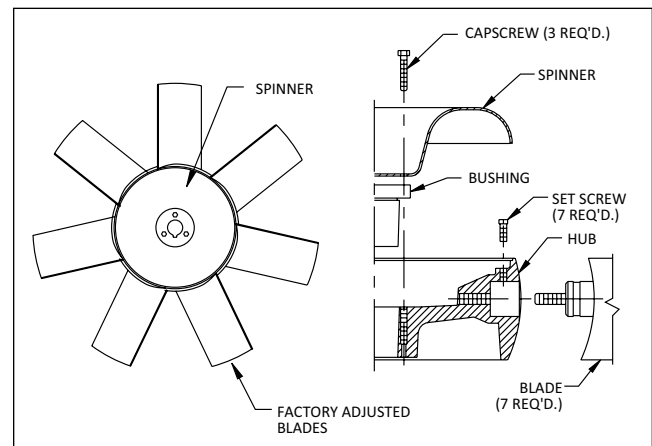

TYPE J - ADJUSTABLE PITCH IMPELLER

BLADE ANGLE ADJUSTMENT

The blades are set at the factory to the blade angle that gives the performance specified on the order. This angle should be checked prior to start-up. The patented impeller construction uses friction and centrifugal force to hold the blades in place. No disassembly of the impeller is required to change the blade angles. If it is necessary to change the blade angle, the following procedure should be used:

1. Work safely. Make sure that proper safety precautions have been followed. Electrical power must be locked off.
2. The adjustment can be made through the inlet on open inlet fans. On fans with ducted inlets, open the impeller area access door.
3. Place adjustment tool around end of blade (see Figure 6, below). If necessary, apply "cheater bar" around the 1 $\frac{1}{4}$ " diameter end for additional leverage.

The blades can be turned by hand on open inlet fans. If additional leverage is needed, place a wrench on the leading edge of the blade near the hub. Take care not to mar the surface of the blade.

4. **Prior to adjusting the blade angle, check the performance data to insure that the motor will not overload.**
5. Turn blade to desired angle. See Figure 1. There is an indicator mark on the hub. Align the Vernier index line on the blade with the indicator mark on the hub. The Vernier has the characters 3, 4 and 5 with gradation lines in between. (Note: Character 3 is 30°, 4 is 40°, 5 is 50°.) Each gradation is 2.5°. The blade is adjustable between 25° and 50°.

6. Friction and centrifugal force will hold the blade at the set angle. No additional adjustment is necessary.
7. **Adjust all blades to the same angle.**
8. Close the impeller area access door before operating the fan.

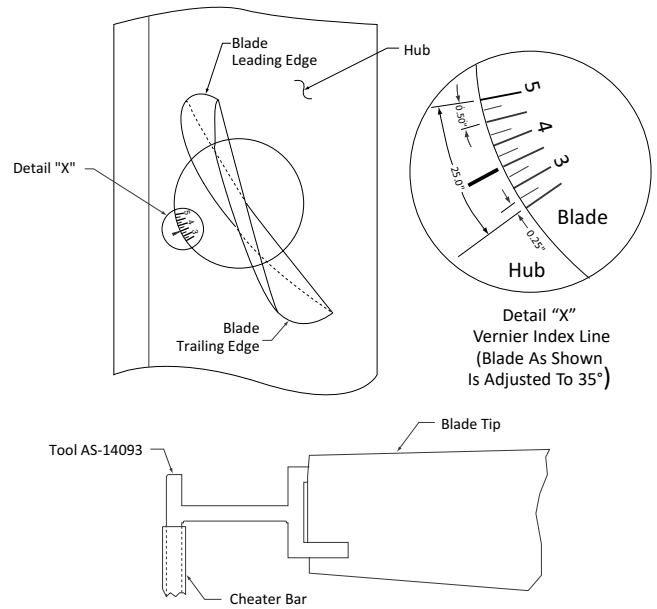

Figure 1.

GENERAL MAINTENANCE

The key to good fan maintenance is a regular and systematic inspection of all fan parts. Severity of the application should determine frequency of inspection. The components requiring service are generally the moving parts, which include bearings,

impeller, belts and sheaves and motor. Included with this shipment is a General Installation and Maintenance Manual (IM-100) covering these items.

CLEANING IMPELLER AND GUIDE VANES

The impeller in an axial flow fan must be kept reasonably clean if it is to perform properly. Fans handling fresh air for ventilating purposes will seldom need cleaning. Fans exhausting process air should be cleaned as required. Dirt or chemical deposits will usually build up evenly on an impeller and although performance is affected, vibration is usually acceptable until the deposits become thick enough to break away in crust-like pieces. When this happens, the impeller may be thrown out of balance and the resulting vibration could be serious. Accumulations should be removed by solvent cleaning or scraping. If the impeller has been coated, be careful not to cut through this protective covering.

The vaneaxial fan is constructed with a set of guide vanes adjacent to the impeller. These should be cleaned at the same time the impeller is cleaned. The guide vanes are important to the performance of the fan and should be inspected carefully. They may accumulate dirt even under conditions where the impeller remains clean.

SUGGESTED INSTALLATIONS

SAME SIZE DUCT

Normal fan installation. Rating tables are based on this arrangement. Variations in installations as indicated below may provide more economical fan performance but may require higher installation costs.

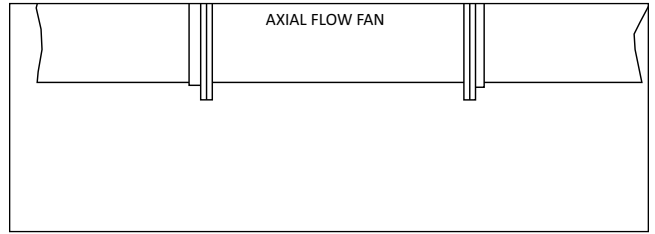

TAPERED DISCHARGE

Allows regain of a portion of the velocity pressure to static pressure. The fan can then be picked at a lower pressure for more economical operation. For specific design information, consult your Aerovent representative.

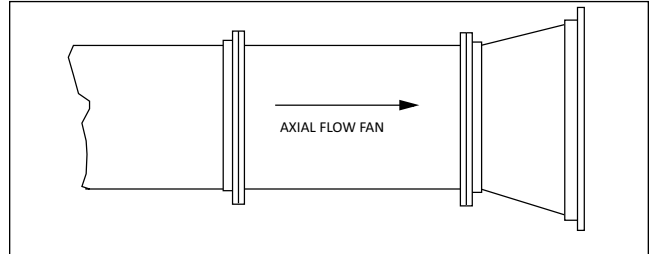

CONVERGING INLET & DISCHARGE

Provides lower duct velocities and less friction to airflow. This allows choosing a fan at lower pressure for more economical operation.

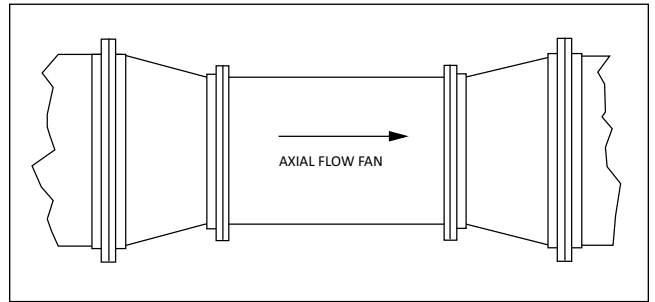

SUGGESTED CONNECTIONS FOR FANS IN DUCT SYSTEMS

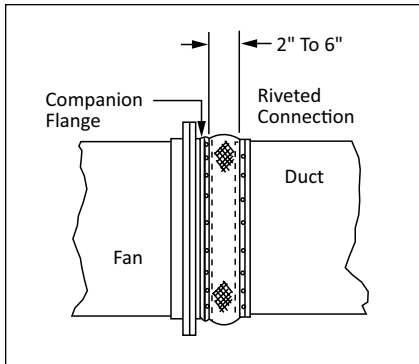

Flexible Connection
Minimum Vibration
(Use Canvas or Other
Suitable Material)

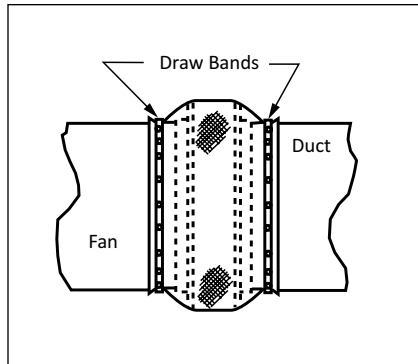

Flexible Connection
Minimum Vibration
(Use Canvas or Other
Suitable Material)

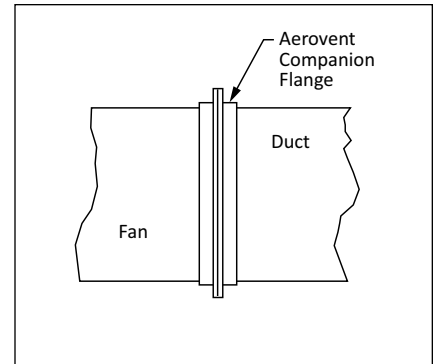

Rigid Connection

Flexible connections between the fan and duct section will reduce vibration to the duct and decrease noise. Mounting the fan on vibration isolators is also necessary for noise dampening.



WWW.AEROVENT.COM

5959 TRENTON LANE N | MINNEAPOLIS, MN 55442 | PHONE: 763-551-7500 | FAX: 763-551-7501