

## Vibration Isolation of Fans

### Introduction

Vibration isolation is used to prevent or limit the amount of force transferred to the supporting structure by a fan in operation. These forces are either undesirable, as in an office setting where they may be distracting or possibly destructive to a process, as in electronic manufacturing where they may cause upset in a production process. In an extreme case, vibration can be destructive enough to destroy the supporting structure.

Whatever the severity of the vibration, rotor unbalance or fluctuating aerodynamic forces cause it. It is good practice to limit the magnitude of both of these sources by good balancing practices and minimizing aerodynamic forces. If the magnitude of vibration is still unacceptable after both of these sources are minimized, often vibration isolation of some sort is required.

In cases where outside vibration may be detrimental to the fan, vibration isolation may also be employed to stop outside vibration from affecting the fan.

### Definition of Vibration Isolation Efficiency and Transmissibility

The general model that is used to define transmissibility (the amount of force transferred through the isolating medium) is based on a single degree of freedom (vertical motion), undamped system on a rigid supporting structure. All of these assumptions are simplistic; there are usually at least six degrees of freedom in rotating machinery, the vibration isolation media do typically provide some damping, and the supporting structure is usually not completely rigid. However, most specifications asking for a degree of vibration isolation efficiency or transmissibility are based on this model, which will be discussed here.

$$F_n = 3.13 \times \sqrt{1/\delta} \text{ (cps)} \quad \delta = \frac{\text{Weight}}{\text{Spring Constant}}$$

$$F_n = 188 \times \sqrt{1/\delta} \text{ (cpm)}$$

$$T = \frac{100}{\left(\frac{F_d}{F_n}\right)^2 - 1} \text{ [%]}$$

$$E = 100 - T \text{ [%]}$$

Where: T = Transmissibility

E = Efficiency

F<sub>d</sub> = Disturbing frequency (frequency that drives the vibration, usually rotational speed of the fan or motor)

F<sub>n</sub> = Natural frequency (Calculated from the deflection of the vibration isolation system)

g = Acceleration of gravity

δ = Deflection of vibration isolation system

Plotting the disturbing frequency as a function of the natural frequency on a logarithmic scale gives lines of transmissibility or vibration isolation efficiency (see Figure 1). Typical levels of isolation efficiency can be specified, usually depending on the criticality of the installation. A practical method suggested by some of the manufacturers of vibration isolation equipment is to consider the horsepower of the driver of the equipment along with the speed of the equipment. These are then tabulated and assigned suggestions for vibration isolation, usually by type of support structure.

The model also assumes that the support structure or foundation is infinitely stiff. If this were true, the isolators would be unnecessary since the support structure would not react to forces transmitted by the rotating equipment. The isolator achieves its function by being soft enough to allow relative vibration without transferring excessive forces to the support structure. Since the structure is not infinitely stiff, however, it acts as a spring in series with the isolator, deflecting proportionally to the isolator in relation to the ratio of their respective spring constants. To perform satisfactorily, the spring constant of the support structure must be at least 10 times that of the isolator, assuring that at least 90% of the spring system constant is provided by the isolator.

Figure 1. Vibration Transmissibility

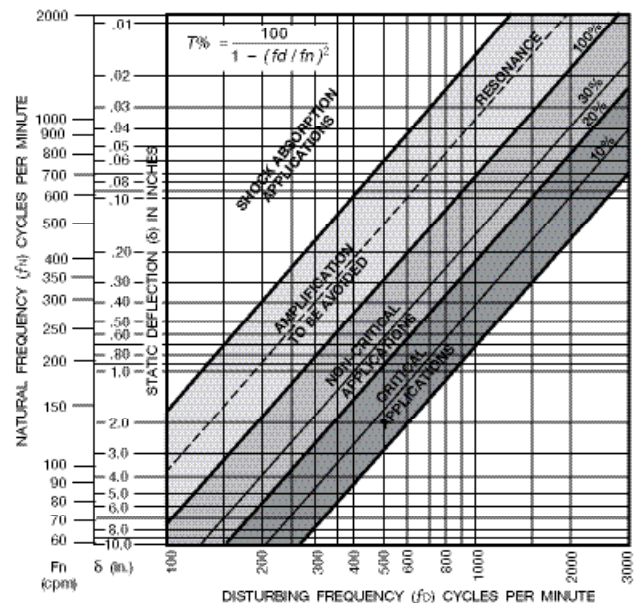

## Types of Support for Vibration Isolation

Equipment is supported on vibration isolation devices such as springs and pads in differing methods depending on the equipment mounted and rigidity of the supporting structure. Light duty equipment may be mounted directly on the devices, but often there is an intermediate supporting structure, which will be discussed here.

In every case where equipment is mounted on isolators, the inlet and outlet must be flexibly connected to the ductwork. Ductwork which is rigidly connected will short circuit the vibration isolation and transmit vibration directly through the ductwork.

**1. Vibration Isolation Base** — This type of base is usually supplied to either support a piece of equipment that has a frame, which is not sufficiently stiff to be isolated independently or to unitize the mounting of a piece of equipment and the driver. It should be mentioned that bases are manufactured solely for the purpose of unitizing the mounting of a piece of equipment and the driver, and are not sufficiently rigid to be mounted on isolation. These are usually referred to as unitary bases, not vibration bases.

The vibration base is constructed of structural members of sufficient depth to provide rigidity for the isolation installation, typically channel, I-beam or angle. If the motor is not mounted on the fan, built in slide rails or a slide base are usually provided as part of the base. To keep the height at a minimum, height saving brackets are also usually built into the base as a standard feature (see Figure 2).

Figure 2. Typical Vibration Isolation Base

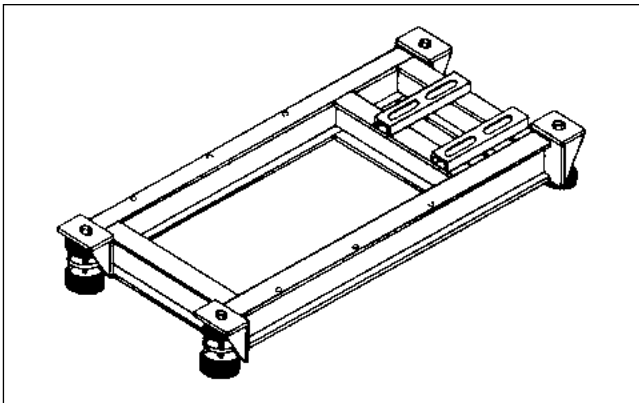

**2. Vibration Isolation Rails** — Vibration isolation rails are sometimes employed in much the same capacity as the vibration isolation base, usually on smaller arrangement 9, 10 or 4 fans. They add stiffness to the mounting platform of the fan and height saving brackets may be used if height needs to be kept to a minimum (see Figure 3).

Figure 3. Typical Vibration Isolation Rails

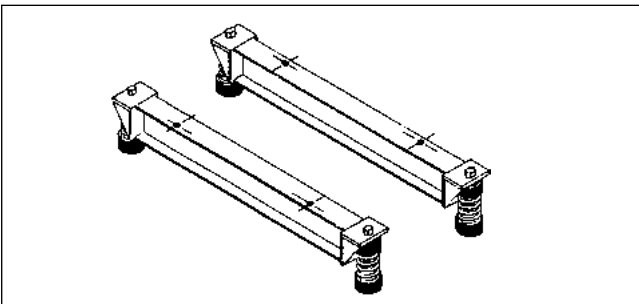

**3. Inertia Bases** — (Concrete filled vibration isolation base) This type of base is used in the same sort of installation as a vibration isolation base. The addition of concrete makes this base considerably stiffer, and the weight of the concrete in the base lowers the center of gravity of the installation, making it more stable on larger equipment. This type of base is preferable on fans that are coupled directly to the motor, as the stiffness helps to maintain coupling alignment. Some fan users prefer that this base be built with structural members stiff enough that the fan can be shipped and handled without the concrete in the base. Some also prefer a bottom pouring pan on this type of base for ease of installation (see Figure 4).

Figure 4. Typical Inertia Base

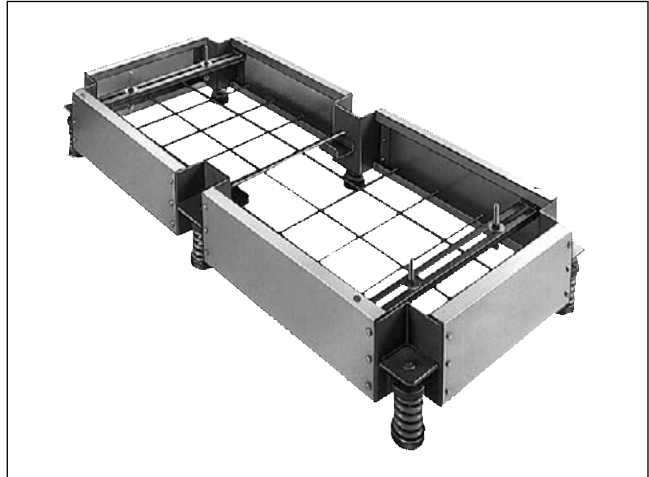

**4. Isolation of Fans Mounted on Curbs** — There are a few types of isolation equipment designed for mounting fans on curbs, usually custom designed for the application. Typically they are variations of the isolation base, sometimes incorporating the roof curb itself into the structure (see Figure 5).

Figure 5. Curb Mounted Vibration Isolation for an Air Handling Unit

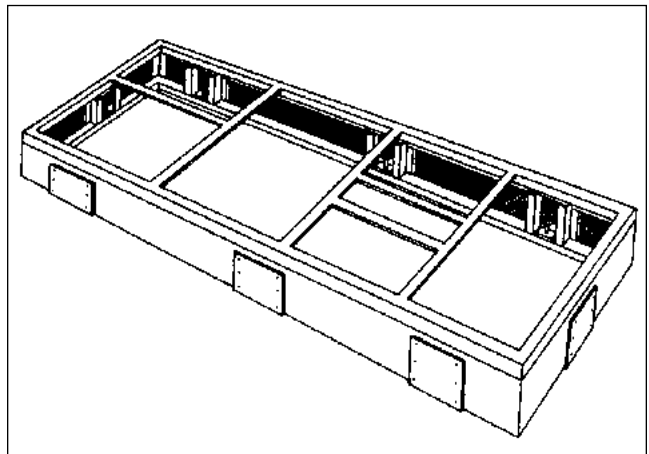

## Vibration Mounts

There are several types of mounts typically used in fan vibration isolation installations, including pads, rubber-in-shear mounts and a variety of springs. The more common varieties will be discussed here.

- 1. Rubber-in-Shear Isolators** — Rubber-in-shear pads consist of two load plates of steel which are embedded in a rubber pad. The equipment to be isolated is bolted to the top load plate and the bottom load plate is attached to the supporting structure. The rubber that is loaded in shear between the load plates provides the deflection that provides for the vibration isolation. The relatively small deflection provided by this type of pad makes it a good selection for vibration isolation on smaller, higher speed fans. Typical deflection is from  $\frac{1}{4}$ " to  $\frac{1}{2}$ " (see Figure 6).
- 2. Open Springs** — Open springs are the simplest of the spring mounts. They are required to be laterally stable without using a housing. This requires a horizontal stiffness to vertical stiffness ratio from about 0.75 to 1.25. The deflection of the spring is at a rated load and usually the spring provides approximately 50% overload capacity. That is, the spring will compress to completely closed at 150% of the design load. Leveling bolts are usually included in the springs to adjust the equipment to level when the springs are loaded. Often a neoprene pad is included between the bottom mounting plate and the supporting structure. Typical deflection is from 1" to 4". The greater deflection provides better vibration isolation efficiency for larger, slower moving fans (see Figure 7).
- 3. Housed Springs** — Housed springs work in the same way as open springs, but are contained in some type of enclosed housing. Often, this housing is telescoping, with rubber pads of some sort between the housing halves, providing some snubbing action for horizontal loads. To provide the necessary load carrying capability, there are sometimes multiple springs in the housing. The requirement for the horizontal to vertical stiffness ratio is usually not as high as for open springs. The spring does usually provide for 50% overload capacity. Often a neoprene pad is included between the bottom mounting plate and the supporting structure. Typical deflection is from 1" to 2" (see Figure 8).
- 4. Restrained Springs** — Usually this type of spring is the same in design as the open springs, but a housing or frame is included to restrain the vertical and/or horizontal motion of the spring. Springs that are vertically restrained are usually used in situations where the vertical loads may have upset conditions, such as wind loading. Horizontally restrained springs may have snubbing features to restrain horizontal loads in cases such as horizontal loads imposed on equipment start up (see Figure 9).
- 5. Pads** — Molded ribbed neoprene pads are used in some instances for isolation of smaller fans. Because of the extremely low deflection provided, these pads provide very little vibration isolation capacity. Typical deflection is about  $\frac{1}{16}$ ".

Figure 6. Rubber-in-Shear



Figure 7. Open Spring



Figure 8. Housed Spring



Figure 9. Restrained Spring



Figure 10. Spring & RIS Hanger



Figure 11. Use of Horizontal Thrust Restraint

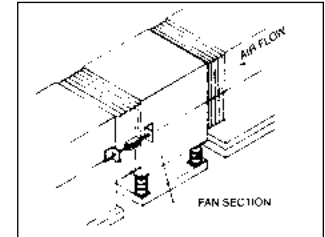

- 6. Hangers** — Most of the isolators listed above have a similar hanger for suspending fans. Spring and rubber-in-shear (RIS) pads are used by themselves and in combination. Deflections and vibration isolation efficiencies are the same as when floor mounted when the same loads are imposed on the vibration isolation element (see Figure 10).
- 7. Horizontal Thrust Restraints** — Horizontal thrust restraints are used to prevent excessive motion of fans due to aerodynamic force. Typically they are springs or spring/RIS pad combinations that are attached to both the fan discharge and the discharge duct. They are adjusted to prevent horizontal motion. To perform properly, they should be installed on the centerline of the thrust force.

## Design Considerations for Vibration Isolation in Seismically Active Zones

Special considerations must be taken when mounting fans on vibration isolation equipment in seismically active zones. Since the equipment is not rigidly mounted on these mounts, provision must be made to restrict lateral motion in the case of a seismic event. The support structure and anchor bolting must be designed to withstand this activity also.

Seismic isolators are specially designed to withstand a specific lateral force. Usually a structural engineer then certifies the isolators for the load.

The Uniform Building Code provides definitions of the seismic zones recognized in the United States. These zones, along with other factors (such as Importance Factors) determine the lateral force the vibration isolation system must withstand. The design of this type of installation and determination of necessary design force are usually made by a certified structural engineer.

Figure 12. Uniform Building Code Seismic Zone Map of the United States

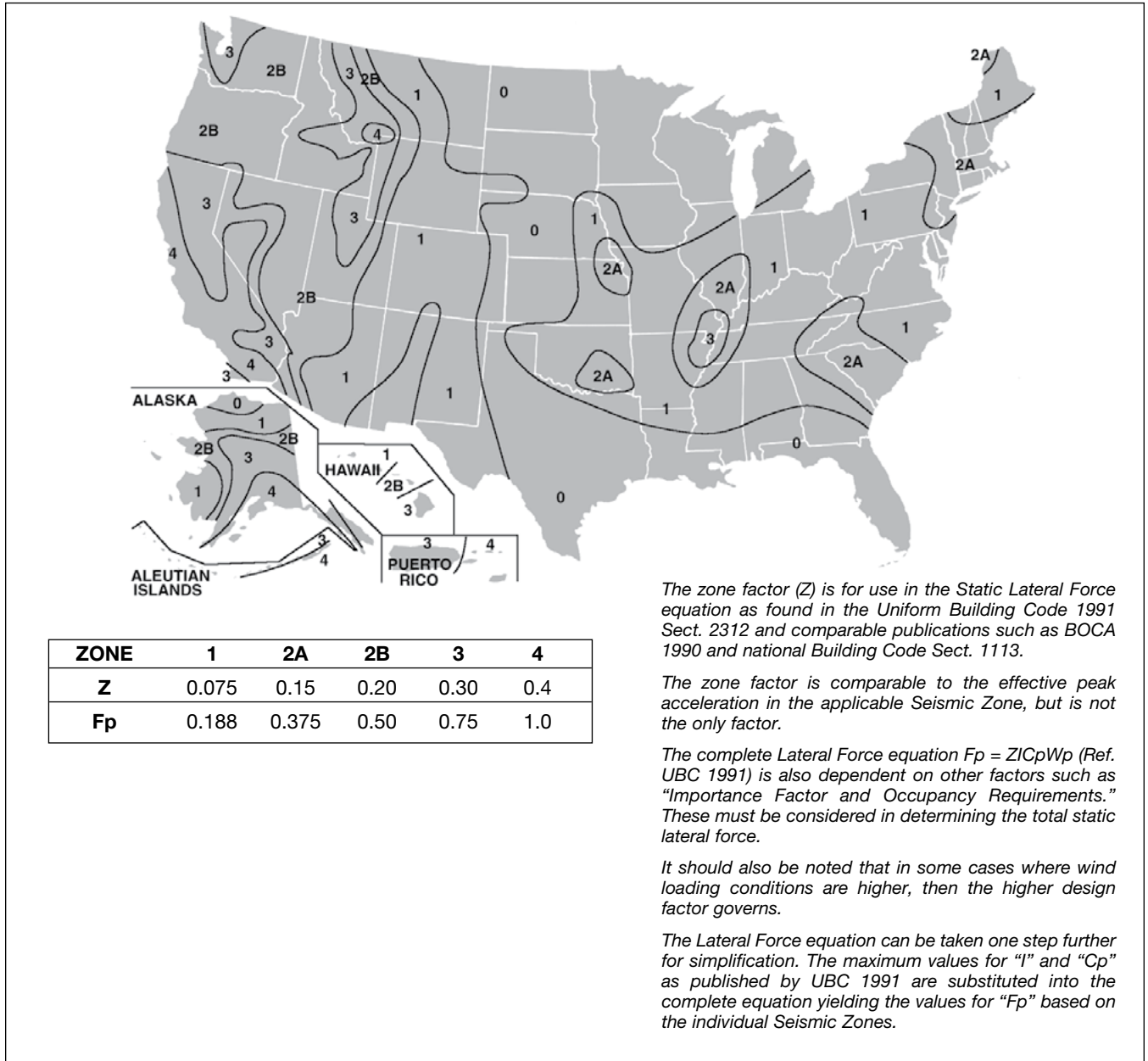

WWW.AEROVENT.COM

5959 TRENTON LANE N. | MINNEAPOLIS, MN 55442 | PHONE: 763-551-7500 | FAX: 763-551-7501

©2021 TWIN CITY FAN COMPANIES, LTD.