

**CONTROLLABLE PITCH-IN-MOTION
& ADJUSTABLE PITCH-AT-REST
VANEAXIAL FANS, AXICO ANTI-STALL®**

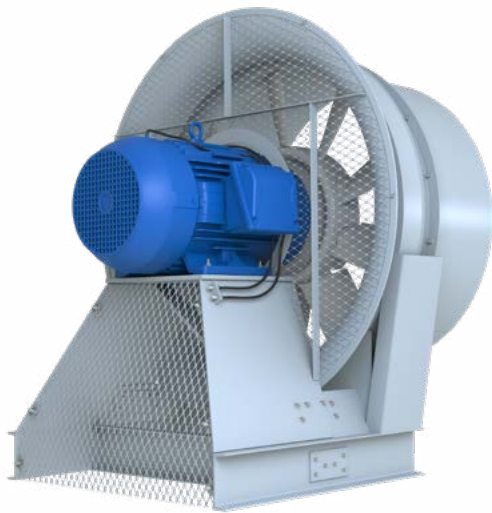

Model FPDA

MODELS: FPAC / FPDA



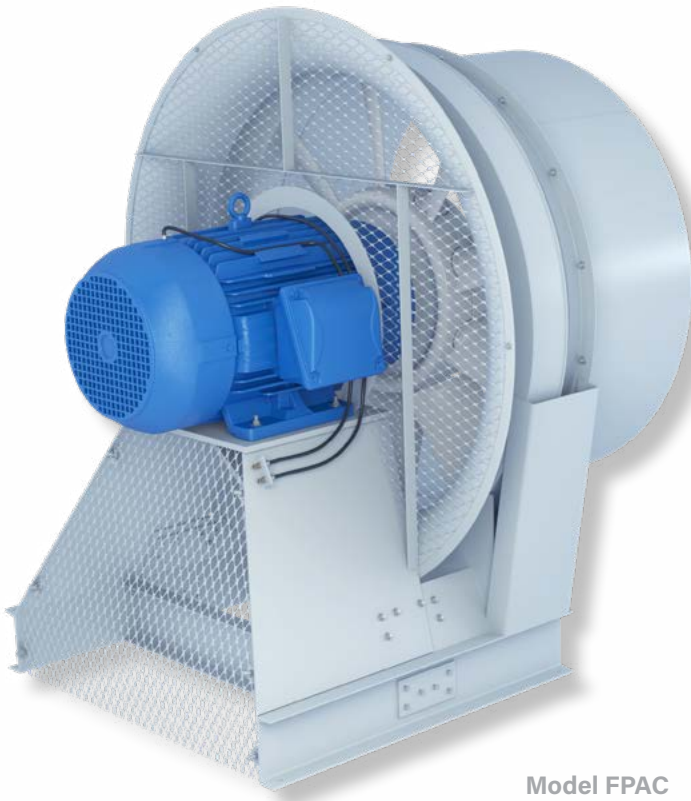

Model FPAC



Energy Regulations

Aerovent supports energy efficiency regulations enacted by the U.S. Department of Energy (DOE) and specific states. The selection and application of fan products is a significant part of these regulations. Engineers and specifiers must understand how to apply Aerovent products to their specific applications to meet applicable DOE and state regulatory requirements. Aerovent has made significant investments in product testing and development to provide efficient products. Developments in Aerovent's Fan Selector software are in place to aid your decision in product selection to assist with meeting the efficiency requirements as stipulated in the applicable regulations.

Models

FPAC | FPDA

AXICO Anti-Stall® is the only controllable pitch vaneaxial fan designed to totally eliminate stall, system surging and increased noise levels often experienced by ordinary controllable pitch vaneaxial fans under unstable conditions.

Normal axial fans can be forced to perform within unstable working ranges when operating conditions are unfavorable. This can happen when the fan system is subjected to sudden or unexpected variations in pressure, which can be caused by:

- dampers that close suddenly or fail to open
- hypersensitive automation control systems
- improper parallel fan starting sequences
- incorrect or optimistic pressure drop calculations
- clogged filters, etc.

When a fan operates in an unstable range the blades are submitted to sharp variations in pressure, which will ultimately result in blade fatigue and eventual fan failure.

AXICO Anti-Stall® provides a patented solution to solve the problems associated with fan stall in a simple, ingenious method, without the addition of any moving parts or expensive electronic controls. The secret lies in the small bypass vanes that are integrated into the chamber placed around the periphery of the fan impeller. The bypass vanes "catch" turbulent airflows produced at the tips of the blades, which normally cause stalling and restore them to stability in the proper flow direction.

AXICO Anti-Stall® has no stall area and no stall limit. While this means that the AXICO Anti-Stall® can be selected directly at any point on the performance curves in this catalog without consideration of any safety range against the possibility of stall, we strongly recommend selections be made toward the central part of the fan curve at the point of highest possible efficiency.

Sizes

32 to 79 inch impeller diameters

Performance

Airflow to 250,000 CFM

Static pressure to 12 inches w.g.



For complete product performance, drawings and available accessories, download our Fan Selector software at aerovent.com.

- Inlet bell designed exclusively for free inlet applications such as custom air handlers (duct configurations also available)
- Vane section provided with removable access panel to provide unimpeded access to fan impeller and blade actuator mechanism
- Fan supported from a welded steel channel base (minimum 5" channel)
- Anti-stall ring with bypass vanes
- NEMA designed foot-mounted motor completely exposed for ease of service and accessibility
- Motor supported on structural base upstream of impeller

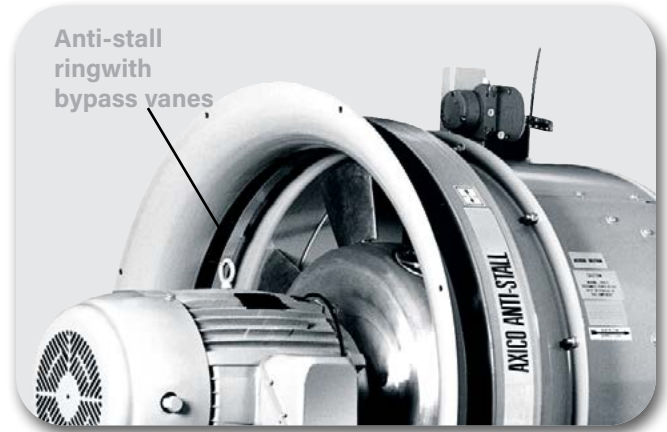

VAV Control Flexibility

The AXICO Anti-Stall® fan can easily be controlled to deliver the required flow or pressure in most situations by properly sizing the fan and then adjusting the blade angle of attack while fan is energized. Blade pitch control can be accomplished in the following ways:

FPAC

Variable air volume fan impeller is equipped with an internal pneumatic diaphragm and external Honeywell industrial-grade pilot positioner assembly to simultaneously vary the pitch angle of all blades identically while the fan impeller is rotating at motor speed. An 80 to 100 psi pneumatic supply air line is required for pitch actuation of this fan. These fans typically operate in a direct-acting mode in conjunction with the building automation temperature control system. The standard pneumatic pilot positioner receives a 3 to 15 psi control signal from the building automation system to modulate the fan blades. An optional electro-pneumatic positioner is available that will modulate blade pitch after receipt of an externally generated 4-20mA electronic control signal.

FPDA

Constant air volume fan impeller is equipped with mechanically-fixed, individually manually-adjustable blades that may only be re-pitched when the fan is stopped. This fan may be operated with a variable frequency drive unit to vary the rotational speed of the impeller and thereby vary the air volume produced while maintaining the Anti-Stall® characteristics of the unit.

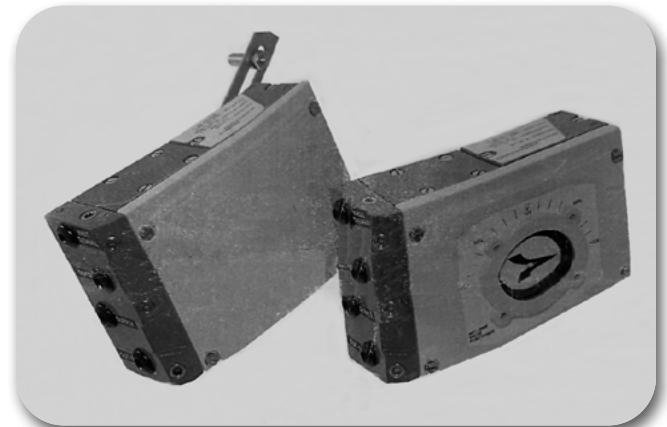

Pneumatic Controllable Pitch

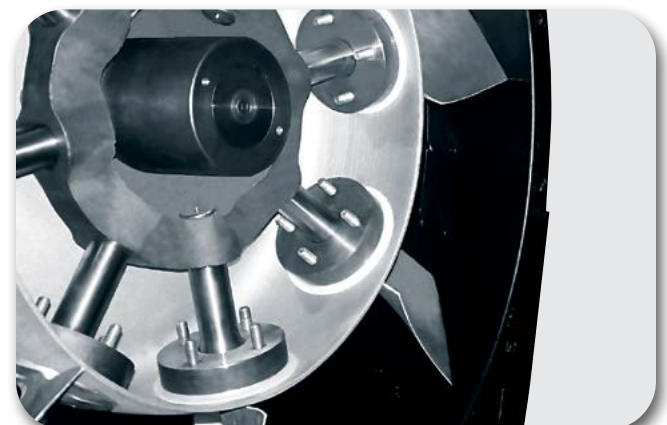

Manual Adjustable Pitch



View of AXICO Anti-Stall® fan from discharge. Honeywell industrial-gauge pilot positioner with closed-loop feedback cable is shown standardly mounted on top of straightening vane section. Bolt-on vane section allows 360° rotation to allow simple field adjustment for improved jobsite accessibility of pilot positioner.



Similar view of fan discharge with standard access panel removed. Every AXICO Anti-Stall® fan in-cludes a 17.75" long by 90° of fan circumference access panel located in straightening vane section. Total service accessibility is provided by this exclusive feature.



As can be seen in this close-up of the inlet bell continuously welded to the patented Anti-Stall® ring, an exclusive AXICO® feature, Anti-Stall® is accomplished by welded bypass vanes without the use of any extra moving parts or electronic "black boxes."



A close-up of the pneumatic controllable pitch impeller mechanism viewed through the standard access panel. Pneumatic supply air (80 to 100 psi) is introduced through the diaphragm through the rotary union (center of photo with feedback cable attached) inflating the pneumatic piston forcing the spider arms to move away from the hub and increase the blade angle of attack.

AXICO Anti-Stall® fans are characterized by completely stable high efficiency operation over an extremely wide operating range. The risk of stall (surging, instability, etc.) encountered in conventional vaneaxial fan designs has been completely eliminated. Fan performance in this publication is presented as Total Pressure versus CFM at standard air density (0.075 lbs/ft³). The maximum blade angles presented in the published performance curves are the maximum angles for which the fan is designed.

For **controllable pitch in-flight** fans in variable volume situations the maximum design load should ideally be selected to the right and slightly above the peak efficiency ring so that normal operation at modulated partial loads will result in operation at areas of highest efficiency on the fan curve.

Fans with **manually adjustable pitch blades** for applications in either constant volume or variable speed (frequency) systems should ideally be chosen for normal operation within the peak efficiency ring of the fan curve to insure the highest possible energy savings throughout the complete range of operation.

The pressure/flow characteristic of the fan is presented as a total pressure rise between the fan inlet and the fan outlet, providing that the fan is connected to ductwork of the same diameter as the fan. The curves are applicable to either a free or a duct connection at the fan inlet and no provision is made for less than ideal fan inlet conditions within the performance curves. The outlet side of the fan is

often connected to a conical regain diffuser that is in turn connected to ductwork or a discharge plenum. Various system requirements and layouts result in numerous combinations of standard or compact fan designs often used in conjunction with a variety of discharge options (ductwork, outlet transitions, C-D diffusers, acoustic diffusers, etc.). The pressure regain and or applicable discharge connection losses for any instance other than that of a fan connected directly to fan diameter discharge ductwork requires the inclusion of these losses in all presentations of Total Pressure.

The following explanation of the performance curves, associated fan laws and formulas should be used to determine and analyze various aspects of fan performance.

SP = Static Pressure

VP = Velocity Pressure

P_v = Velocity pressure in fan diameter duct

P_{vD} = Velocity pressure in diffuser diameter duct

DL = Discharge Loss

TP = Total Pressure

TE = Total Efficiency

bHP = Brake Horsepower

TP = SP + VP + DL

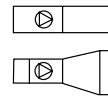
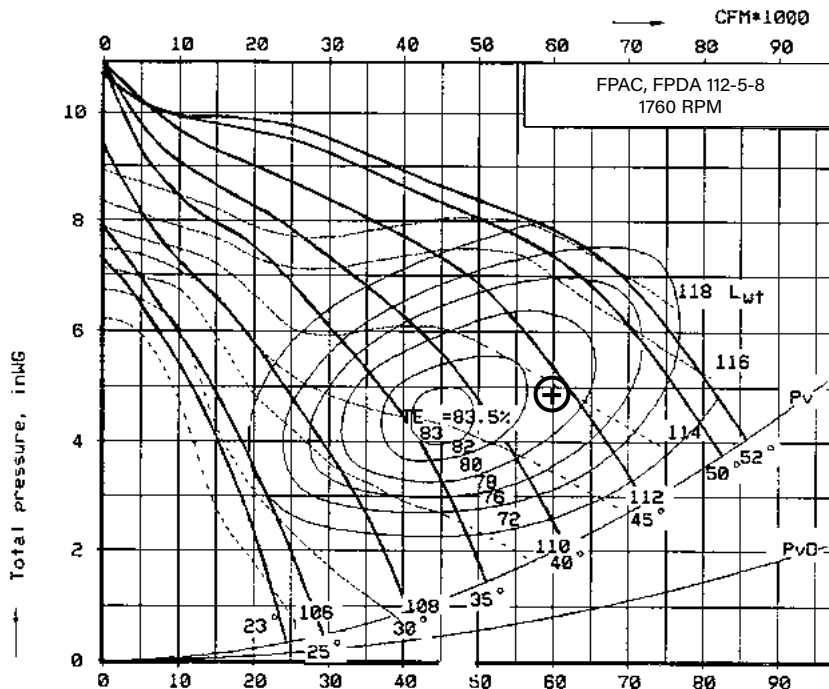
$$\text{bHP} = \frac{\text{CFM} \times \text{TP}}{6356 \times \text{TE}}$$

Fan chart is valid for a gas density of .075 lb/ft³.

L_wt: Total sound power level dB(A)

P_v: Velocity pressure in fan diameter duct

P_{vD}: Velocity pressure in diffuser diameter duct

TE: Total efficiency

Model Nomenclature

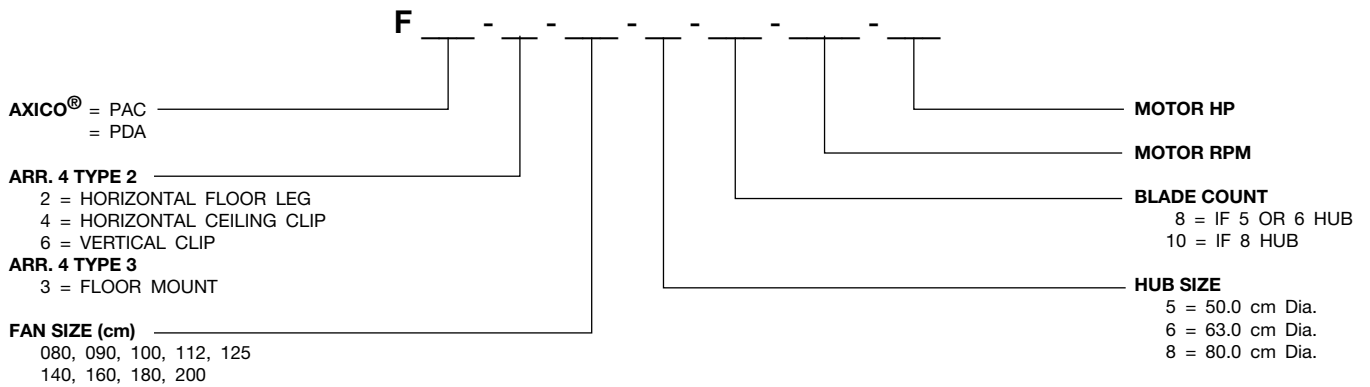

NOTES:

1. Motor frame size must be specified in the body of the order and will no longer be indicated within the model number.
2. Blade pitch setting must be indicated in the body of the order.

Dimensional Data

Model FPDA Compact Design: Arr. 4, Type 3

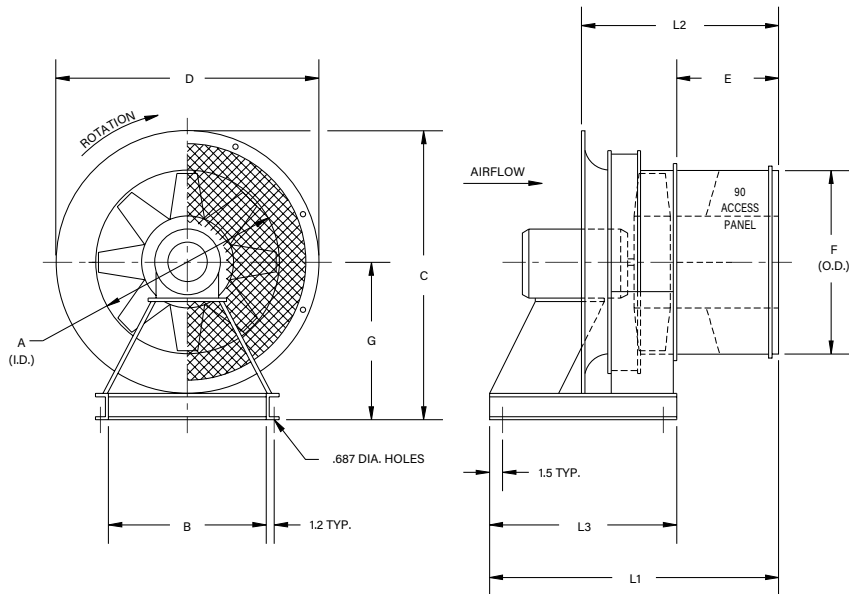

FAN SIZE	A	B	C	D	E	F	G	L1	L2	L3	APPROX. WT. (LBS.)*
080	31.50	28.00	48.50	41.50	17.75	31.71	28.00	47.00	33.25	29.13	910
090	35.43	30.00	52.70	45.40	17.75	35.64	30.00	48.00	33.25	30.70	1000
100	39.37	34.00	56.70	49.40	17.75	39.58	32.00	49.00	33.25	31.70	1080
112	44.09	37.00	62.05	54.10	17.75	44.30	35.00	56.00	33.25	38.18	1230
125	49.21	42.00	71.60	63.20	17.75	49.42	40.00	60.00	35.25	42.25	1405
140	55.12	45.00	78.55	69.10	17.75	55.33	44.00	60.00	35.25	42.25	1655
160	63.00	48.00	85.50	77.00	17.75	63.21	47.00	60.00	35.25	42.25	1880
180	70.87	53.00	93.45	84.90	17.75	71.08	51.00	60.00	35.25	42.25	2055
200	78.74	58.00	100.35	92.70	17.75	78.95	54.00	60.00	35.25	42.25	2415

R101094A

DIMENSIONS ARE NOT TO BE USED FOR CONSTRUCTION.

*SHIP WEIGHT LESS MOTOR

Model FPDA Compact Design: Arr. 4, Type 2 (Floor Mount)

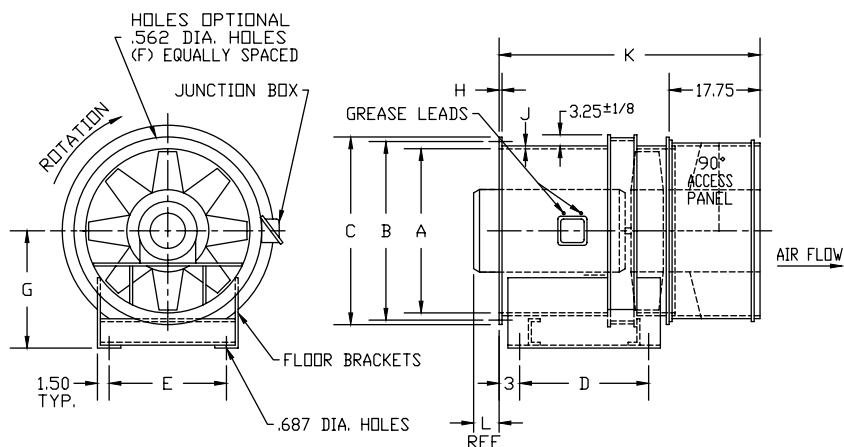

FAN SIZE	A	B	C	D	E	F	G	H	J	K
071	27.95	29.85	31.42	22.00	20.00	12.00	20.00	0.25	0.25	46.00
080	31.50	33.38	34.50	23.00	23.00	12.00	22.00	0.25	0.25	47.00
090	35.43	37.31	38.43	30.00	25.00	12.00	24.00	0.25	0.25	54.00
100	39.37	41.25	42.37	30.00	28.00	12.00	26.00	0.25	0.25	54.00
112	44.09	45.97	47.09	34.00	31.00	16.00	28.00	0.25	0.25	58.00
125	49.21	51.09	52.21	34.00	35.00	16.00	33.00	0.25	0.25	58.00
140	55.12	57.37	59.12	34.00	39.00	24.00	36.00	0.25	0.25	58.00
160	63.00	65.25	67.00	34.00	45.00	24.00	40.00	0.25	0.25	58.00
180	70.87	73.37	74.87	34.00	50.00	30.00	43.00	0.25	0.25	58.00
200	78.74	81.24	83.34	34.00	56.00	30.00	47.00	0.25	0.25	58.00

R101114B

DIMENSIONS ARE NOT TO BE USED FOR CONSTRUCTION.

Model FPDA Compact Design: Arr. 4, Type 2 (Horizontal Clip Mount)

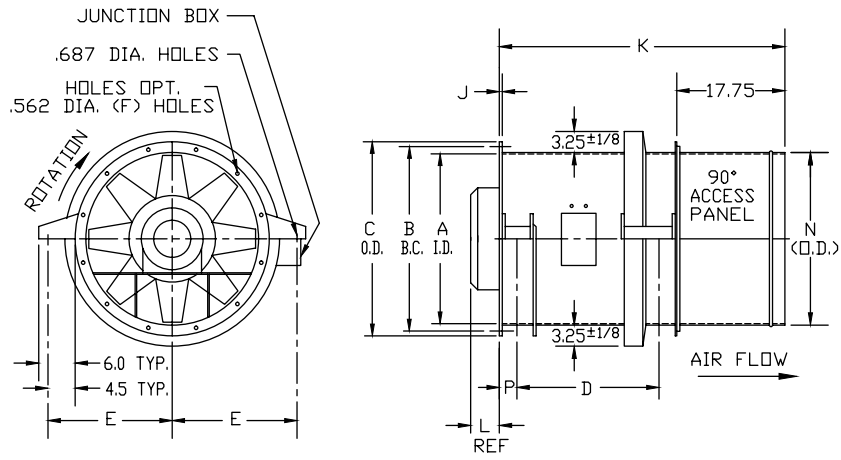

FAN SIZE	A	B	C	D	E	F	J	K	N	P
071	27.95	29.85	31.42	23.00	18.67	12.00	0.25	46.00	28.16	2.625
080	31.50	33.38	34.50	24.00	20.44	12.00	0.25	47.00	31.71	2.625
090	35.43	37.31	38.43	31.00	22.41	12.00	0.25	54.00	35.64	2.625
100	39.37	41.25	42.37	31.00	24.38	12.00	0.25	54.00	39.58	2.625
112	44.09	45.97	47.09	35.00	26.74	16.00	0.25	58.00	44.00	2.625
125	49.21	51.09	52.21	35.00	29.30	16.00	0.25	58.00	49.42	2.625
140	55.12	57.37	59.12	35.00	32.31	24.00	0.25	58.00	55.33	2.625
160	63.00	65.25	67.00	35.00	36.25	24.00	0.25	58.00	63.21	2.625
180	70.87	73.37	74.87	35.00	40.18	30.00	0.25	58.00	71.08	2.625
200	78.74	81.24	83.34	35.00	44.12	30.00	0.25	58.00	78.95	2.625

R101089B

DIMENSIONS ARE NOT TO BE USED FOR CONSTRUCTION.

Model FPDA Compact Design: Arr. 4, Type 2 (Vertical Mount)

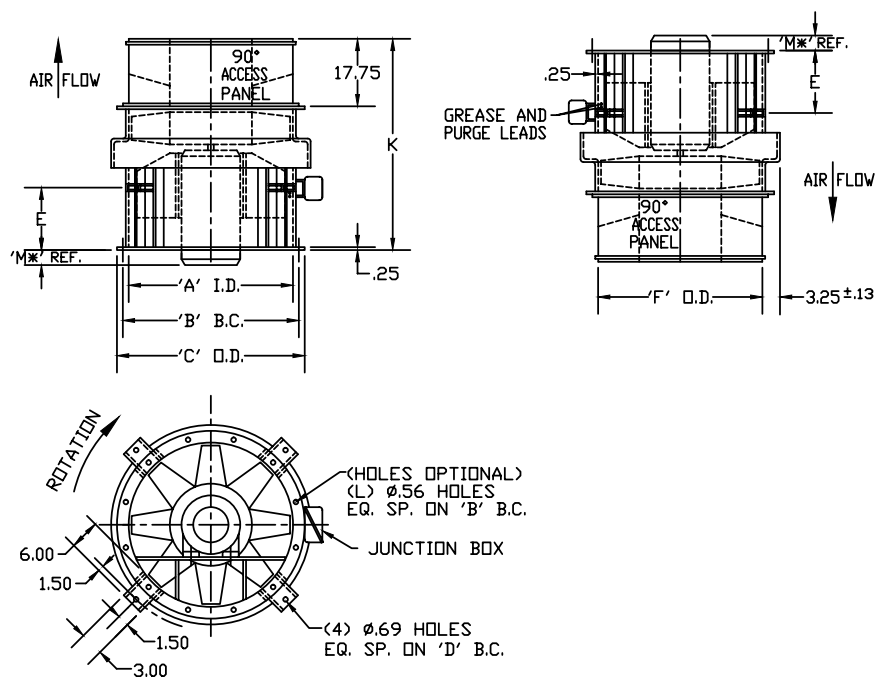

FAN SIZE	A	B	C	D	E	F	K	L
071	27.95	29.85	31.42	37.33	14.12	28.16	46.00	12.00
080	31.50	33.38	34.50	40.88	14.62	31.71	46.00	12.00
090	35.43	37.31	38.43	44.81	18.12	35.64	54.00	12.00
100	39.37	41.25	42.37	48.75	18.12	39.58	54.00	12.00
112	44.09	45.97	47.09	53.48	20.12	44.00	58.00	16.00
125	49.21	51.09	52.21	58.60	20.12	49.42	58.00	16.00
140	55.12	57.37	59.12	64.62	20.12	55.33	58.00	24.00
160	63.00	65.25	67.00	72.50	20.12	63.21	58.00	24.00
180	70.87	73.37	74.87	80.36	20.12	71.08	58.00	30.00
200	78.74	81.24	83.34	88.24	20.12	78.95	58.00	30.00

R101119C

DIMENSIONS ARE NOT TO BE USED FOR CONSTRUCTION.

WALL MOUNTED FANS | TUBEAXIAL & VANEAXIAL FANS | CENTRIFUGAL FANS & BLOWERS
ROOF VENTILATORS | AIR HEATERS & COOLERS | AIR MAKE-UP | FIBERGLASS FANS | CUSTOM FANS

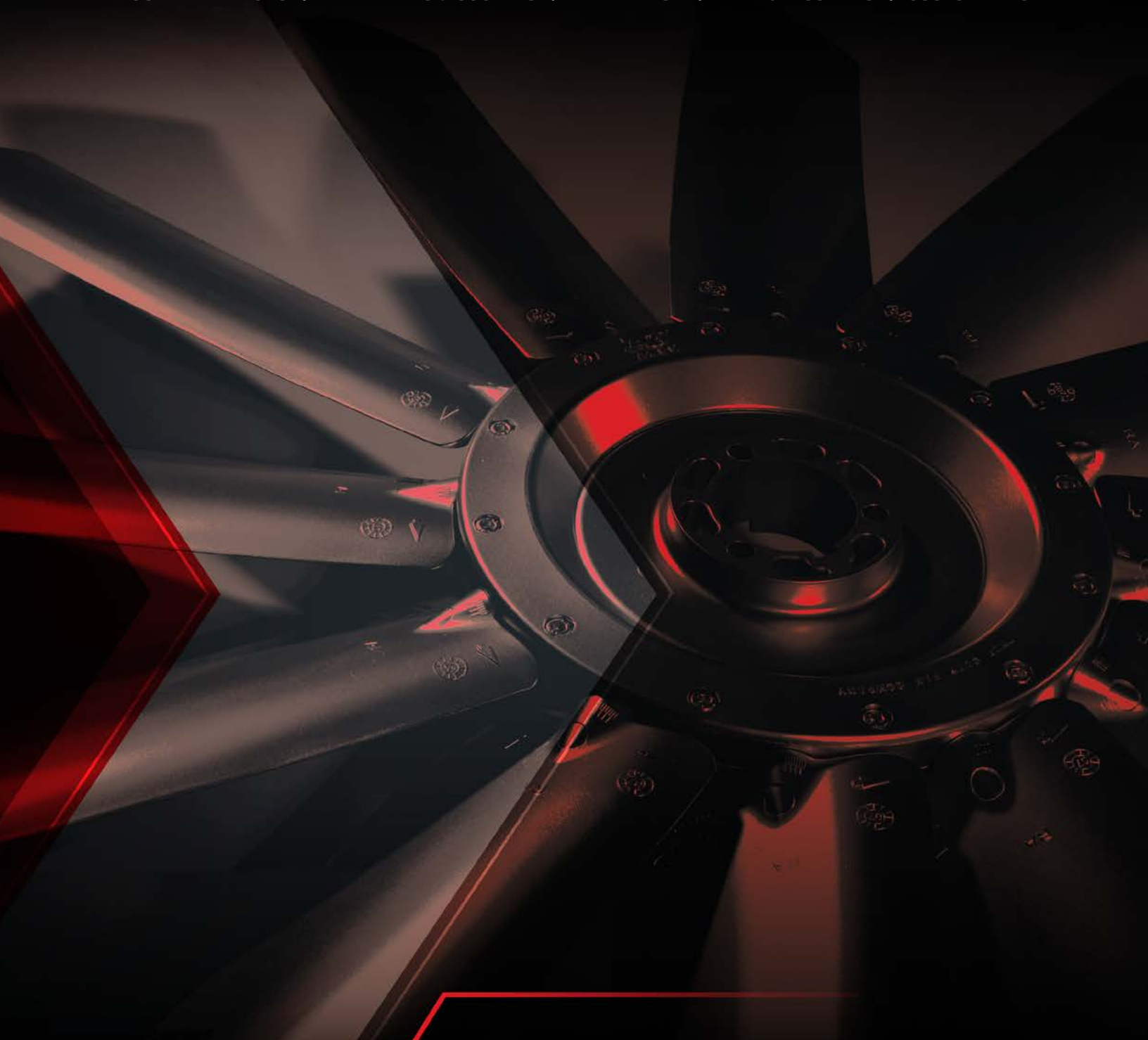

AEROVENT 
INDUSTRIAL VENTILATION SYSTEMS

AEROVENT.COM

5959 Trenton Lane N. | Minneapolis, MN 55442 | Phone: 763-551-7500 | Fax: 763-551-7501

©1999-2024 Aerovent, Minneapolis, MN. All rights reserved. Catalog illustrations cover the general appearance of Aerovent products at the time of publication and we reserve the right to make changes in design and construction at any time without notice.