

General Installation, Operation and Maintenance Instructions For Aerovent Products

Throughout this manual, there are a number of HAZARD WARNINGS that must be read and adhered to in order to prevent possible personal injury and/or damage to equipment. The signal word "WARNING" is used to indicate the severity of a hazard and is preceded by the safety alert symbol.

⚠ WARNING

Used when serious injury or death MAY result from misuse or failure to follow specific instructions.

It is the responsibility of all personnel involved in installation, operation and maintenance to fully understand the ⚠ Warning procedures by which hazards are to be avoided.

ASSEMBLY PROCEDURES

1. Lay hub on a horizontal surface with openings of shank sockets (Fig. 3) facing up. This is normally the discharge side of the assembly.
2. Lay blade shank in socket with discharge side of the blade up. The discharge side of the blade is the side with the angle setting mark. Line up the index mark on the blade with the proper angle mark on the end of the shank socket (Figs. 2 and 4) on the underside of assembly.
3. Place cap over blade shank with beveled end toward center. Install U-bolts and elastic nut stops. Before tightening lock nuts, pull the blade outward to set the key against the keyway and check angle setting (Fig. 3).
4. Tighten elastic stop nuts evenly and torque to the following foot-pounds:

IMPELLER DIA.	HUB DIA.	U-BOLT SIZE	TORQUE (FT/LBS)	
			ALUMINUM	FIBERGLASS
54" - 72"	14"	1/2"	20	30
81" - 144"	18"	3/4"	45	50

5. Check angle setting to be sure it has not changed during assembly. If so, loosen lock nuts and reset angle. Tighten nuts again to proper torque. Do not over-tighten. Be sure to tighten U-bolts evenly.

SETTING ANGLE WITH PROTRACTOR (OPTIONAL)

Under most conditions, the preceding assembly procedure using the index marks is of sufficient accuracy. When greater accuracy is desired, use a level bubble protractor. Before the final tightening of the nuts, set the protractor on the angle setting mark. (The hub and blade assembly must be level for accurate setting.) Adjust the angle by tapping the shank end with a mallet. Tighten lock nuts to proper torque. Again check

the angle setting. Rotate impeller to check angle on each blade in the same location.

Impellers may be assembled so the cap side of the hub is the inlet side (reverse bore). If blades do not have the index mark on the discharge side, it is then necessary to adjust the blade angle with a protractor.

Fig. 2

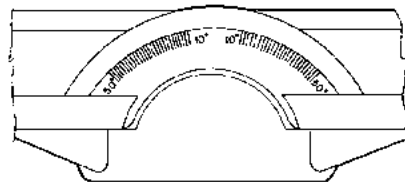

Angle setting index on shank socket. Marked from 10° through 50°. Each mark is 2°. When hub is viewed as shown above, scale on left side should be used for right-hand impeller and scale on right side should be used for left-handed impellers.

Fig. 3

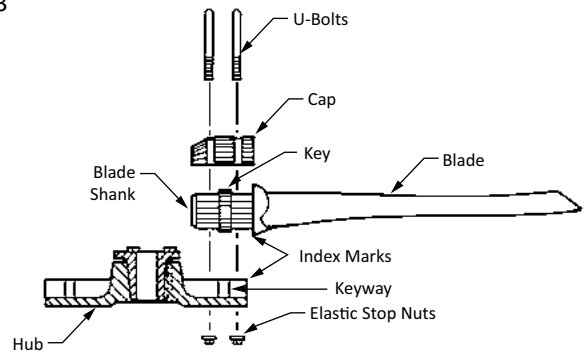

Fig. 4

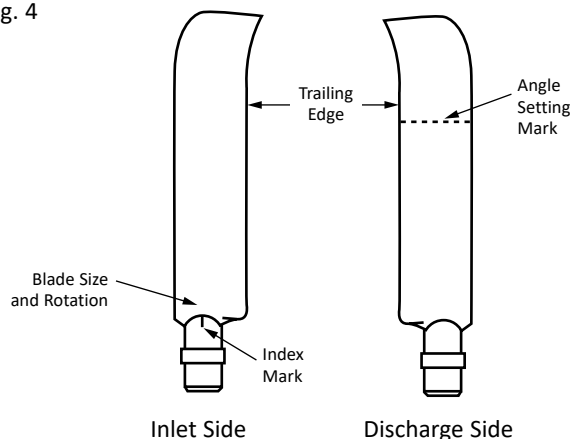
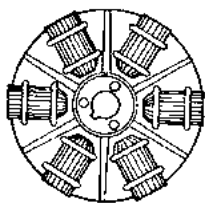
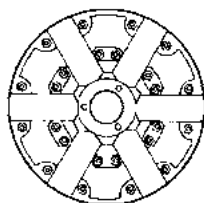

Fig. 1



Cap and U-Bolt Side



Lock Nut Side

The hub and blades are balanced separately. The weight distribution throughout the length of the blade varies slightly. Therefore, the balance is to a constant moment and blades may be assembled at random even though the weights are slightly different. Blades are marked for size and rotation (Fig. 4). "54 R" means a 54" diameter fan with right-hand rotation.

Right-hand or left-hand rotation of impellers is determined as follows: When facing into the discharge of the fan, clockwise rotation is right-hand; counterclockwise rotation is left-hand. The thicker rounded edge of the blade or edge opposite the pointed tip is the leading edge.

INSTALLATION INSTRUCTIONS FOR IMPELLERS EQUIPPED WITH BROWNING MALLEABLE IRON SPLIT TAPER BUSHINGS

Aerovent adjustable pitch impellers are furnished with hubs that have a tapered bore. A split taper bushing is used for mounting the impeller assembly to the shaft. When properly assembled, the bushing grips the hub and the shaft with a positive clamping action. The split taper bushing is always mounted on the discharge or cap side of the hub unless the impeller has been ordered with a reverse bore.

- A. Bushing barrel and bore of impeller hub are tapered. This assures concentric mounting and a true running impeller.
- B. Capscrews, when tightened, lock bushing in impeller. Use plated capscrews threaded full length (see table below).

BUSH NO.	CAPSCREW			TORQUE (FT/LBS)
	SIZE	THREADS/IN	LENGTH	
Q2	3/8"	16	2 1/2"	24
R2	3/8"	16	3"	24

- C. Bushing is split so that when the locking capscrews force bushing into tapered bore, the bushing grips the shaft with a positive clamping fit. This will withstand vibration and punishing loads without being loosened.
- D. Impeller and bushing assembly is keyed to shaft and held in place by compression. This gives added driving strength.

INSTALLATION INSTRUCTIONS

Put bushing loosely into impeller. Do not press or drive. Start capscrews by hand, turning them just enough to engage threads in tapped holes on impeller. Do not use a wrench at this time. The bushing should be loose enough in the impeller to move slightly.

Be sure shaft and keyway are clean and smooth. Check key size with both shaft and bushing keyways. Slide impeller and bushing assembly onto shaft, making allowance for end play of shaft to prevent rubbing. Do not force impeller and bushing onto shaft. If it does not go on easily, check shaft, bushing and key sizes.

Tighten capscrews progressively with wrench. Do this evenly as in mounting an automobile wheel. Take a part turn on each capscrew successively until all are tight.

These capscrews force the taper bushing into the hub which in turn compresses the bushing onto the shaft. This makes a positive clamping fit. The torque must not exceed 24 ft. lbs. for Q bushings and for R bushings.

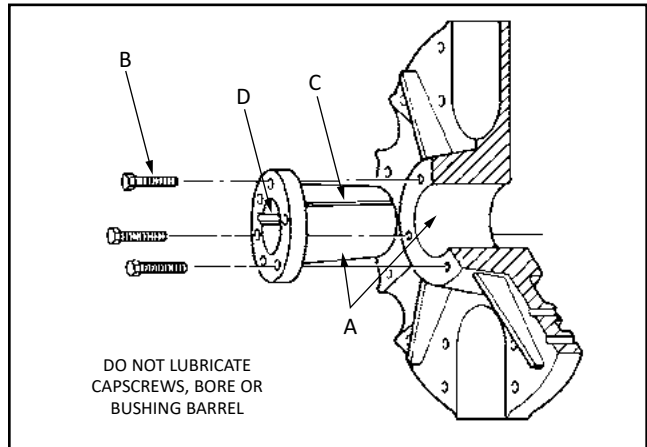

WARNING

Do not attempt to pull bushings flange flush with hub end. There should be 1/8" to 1/4" clearance when tightened.

REMOVING IMPELLER ASSEMBLY FROM SHAFT

Impeller is easily removed from shaft by inserting and tightening two of the capscrews into the tapped holes in the bushing flange. This forces the bushing loose from the impeller and releases the compression so that the entire assembly will slide from the shaft.

1. Remove all three capscrews from impeller and hub assembly.
2. Start capscrews into the threaded holes in the bushing flange.
3. Tighten each bolt part of a turn successively to force the impeller off the bushing.
4. Pull the bushing off the shaft. If the assembly has been in place some time, it may be necessary to use a wheel puller to remove the bushing. Never use a wheel puller on the impeller.

For impeller dimensions, see Drawing R-9183.



WWW.AEROVENT.COM