

## V-Belt Drive Selection For Fans

### Achieving Optimum Performance

#### Introduction

Proper V-belt drive selection can have a dramatic influence on the life of the fan/motor assembly. Improved belt life, lower maintenance costs and higher efficiencies can be obtained with minimal increase in initial cost. The information in this document, based on years of fan experience, will help you select and maintain drives for your fan needs.

Before a discussion on selecting optimum drives, let us review the variables which affect the selection of the drives. Figure 1 shows a variety of belt cross sections and Figure 2 shows a comparison of drive bushings and

sheaves. There are cast iron and stamped steel sheaves. Cast iron sheaves are used up to 6500 fpm. Stamped steel sheaves are less expensive and are only "safe" to 5000 fpm. A sheave can be mounted using either a taper-bushing or set screw mounted bushing. Taper-bushings are better than set screw mounted bushings since they are more concentric, resulting in less vibration and better "holding" properties. Sheaves are available as either fixed pitch or variable pitch. It will be explained later that fixed pitch sheaves exhibit less vibration than variable pitch sheaves.

Figure 1. Belt Identification

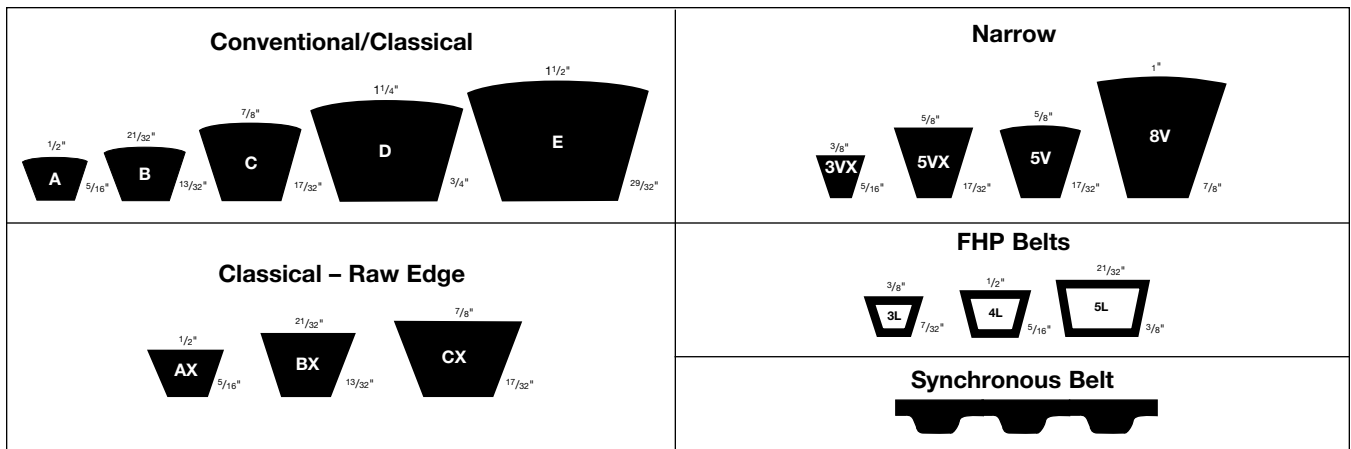
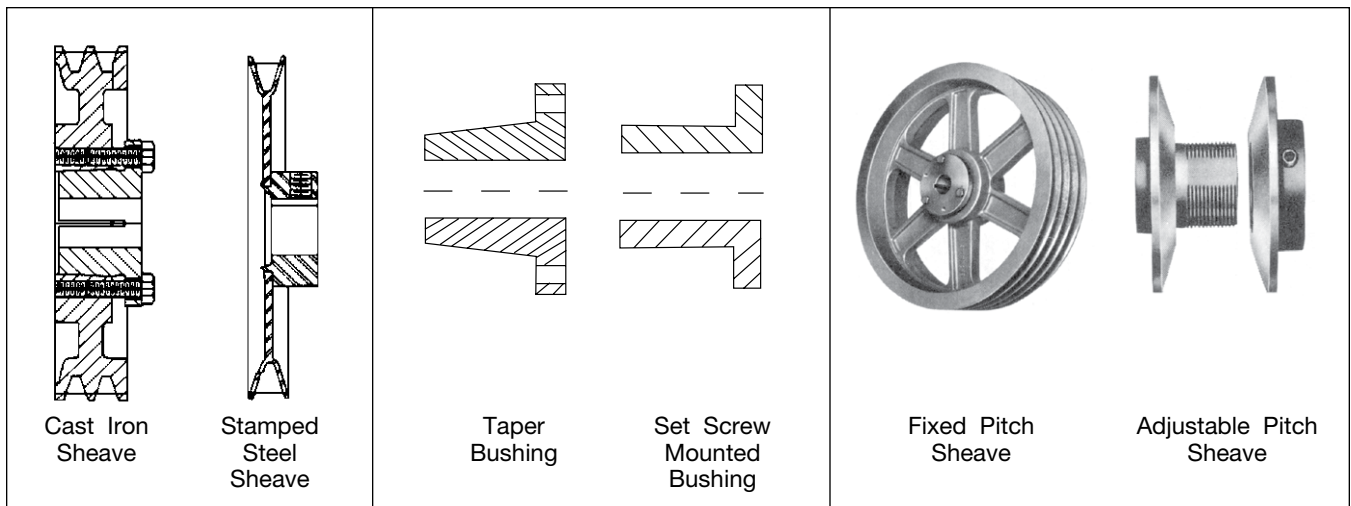

Figure 2. Comparison of Drive Bushings and Sheaves



# How a V-Belt Drive Is Selected

A V-belt drive works when friction between the side of the belt and sheave causes the shaft to rotate. The equations using this friction are beyond the scope of this paper but they are based on Euler's equation. Euler's equation is accurate for a flat belt drive but is only a gross approximation for a V-belt drive, even with the inclusion of factors to account for groove angle and wedging. It is not accurate for speed-up drives which will be discussed later. It is important to note that current industry practice for selecting belts is based on the extension of Euler's equation.

"Pitch diameter" is the effective diameter of the sheave, which is used to determine the pitch length of the belt for center distance calculation. The drive ratio is the driver speed divided by the driven speed. "Hub load" is the result of belt tension, which is the vector sum of the tight side tension and the slack side tension. Hub load is directly proportional to the horsepower and indirectly proportional to the product of RPM and pitch diameter. The greater the hub load the lower the bearing life.

## General Guidelines for Selection of Drives

When you select drives from other sources, the selection is usually based on a computer program that considers the motor limits but not the fans. We encourage you to use the following guidelines to select drives for your fan needs. These guidelines are based on years of fan experience.

1. When using common drive selection programs, select the following:
  - a. If the product cost is within 10%, the selection of raw edge cog belts over wrapped belts will normally provide better value.
  - b. Classical belts are a better selection than narrow belts (3V-5V-8V). In general, maintenance departments do a poor job of tensioning narrow belts to the higher tensions required.
  - c. It is desirable to select a drive using as few belts as possible.
  - d. The lowest hub load is recommended to improve bearing life.
  - e. Purchase finish bore sheaves only when split taper-bushing sheaves are not available (for example, do not purchase a 2AK30 in finished bore since a 2AK30H with "H" bushings is available).
2. Follow the minimum pitch diameters on both the motor and fan whenever possible (see Tables 1 and 2). On speed-up drives consult the fan manufacturer for minimum pitch diameters if not published in the catalog and NEMA minimums cannot be followed. In no case should the fan sheave be smaller than 3" in diameter.
3. Maximum belt speed should not exceed 6500 fpm. A pulley running at more than 6500 fpm may cause vibration, noise, poor bearing life, and high fatigue stresses. Some pulleys may require dynamic balancing at speeds less than 6500 fpm. Purchase dynamic balance sheaves when the RPM is greater than the maximums determined in Figure 3.
4. Always use at least a two-groove minimum on 7.5 horsepower and higher motors.

Two-groove drives are not recommended on fractional horsepower motors since motors may not

Table 1. Minimum Recommended Sheave Diameters (in.) For Electric Motors\*

MOTOR HP	MOTOR RPM			
	870	1160	1750	3500
1/2	2.2	—	—	—
3/4	2.4	2.2	—	—
1	2.4	2.4	2.2	—
1½	2.4	2.4	2.4	2.2
2	3.0	2.4	2.4	2.4
3	3.0	3.0	2.4	2.4
5	3.8	3.0	3.0	2.4
7½	4.4	3.8	3.0	3.0
10	4.4	4.4	3.8	3.0
15	5.2	4.4	4.4	3.8
20	6.0	5.2	4.4	4.4
25	6.8	6.0	4.4	4.4
30	6.8	6.8	5.2	—
40	8.2	6.8	6.0	—
50	8.4	8.2	6.8	—
60	10.0	8.2	7.4	—
75	10.0	10.0	8.6	—
100	12.0	10.0	8.6	—
125	—	12.0	10.5	—
150	—	—	10.5	—
200	—	—	13.2	—
250	—	—	—	—
300	—	—	—	—

\*NEMA standards

Table 2. Minimum Recommended Sheave Diameters (in.) For Fan Sheaves

MOTOR HP	FAN RPM								
	1-999	1000-1499	1500-1999	2000-2499	2500-2699	2700-2999	3000-3499	3500-3999	3500-
1/2	3.0	3.0	3.0	3.0	3.0	3.0	3.0	3.0	3.0
3/4	3.0	3.0	3.0	3.0	3.0	3.0	3.0	3.0	3.0
1	3.0	3.0	3.0	3.0	3.0	3.0	3.0	3.0	3.0
1½	3.0	3.0	3.0	3.0	3.0	3.0	3.0	3.0	3.0
2	3.0	3.0	3.0	3.0	3.0	3.0	3.0	3.0	3.0
3	3.5	3.0	3.0	3.0	3.0	3.0	3.0	3.0	3.0
5	4.0	3.5	3.2	3.0	3.0	3.0	3.0	3.0	3.0
7½	4.9	4.2	3.8	3.5	3.4	3.3	3.1	3.0	3.0
10	5.5	4.8	4.3	4.0	3.9	3.8	3.5	3.4	3.4
15	6.5	5.6	5.2	4.8	4.7	4.5	4.3	4.2	4.2
20	7.5	6.5	5.8	5.4	5.2	5.0	4.6	4.5	4.5
25	8.1	7.0	6.5	5.9	FAN SELECTION NOT RECOMMENDED				
30	8.8	7.5	6.8	6.5					
40	10.0	8.6	7.8	7.3					
50	11.0	9.5	8.6	8.0					
60	12.0	10.4	9.4	8.6					
75	13.2	11.2	10.2	9.6					
100	14.9	12.8	11.6	—					
125	16.5	14.0	12.8	—					
150	17.6	15.2	13.1	—					
200	20.0	17.2	13.1	—					

On fan speeds 2700 RPM and up (shaded area), a 3600 RPM T frame (not TS) motor is recommended.

If an application is NOT RECOMMENDED, consult factory.

start the fan because the frictional forces may exceed the starting torque of the motor. It is not necessary to have an extra belt because the reliability of the belts has improved over time. On 25 through 60 horsepower motors use a three-groove minimum, and on 75 horsepower and higher use a four-groove drive minimum.

5. Fan sheaves should always have a taper-bushing on applications using one horsepower and higher motors.
6. If belt length exceeds 158", then purchase machine matched belts.
7. Avoid excessive service factors. A 1.5 service factor is adequate for all normal electric motor driven fans, and service factors over 3.0 can cause problems. It is recommended that the minimum service factor should be 1.2 for up to 25 horsepower and 1.5 for 30 horsepower and greater.

Figure 3. To Determine the Need for Dynamic Balance

This chart shows the maximum speed limit (in RPM) for a standard statically balanced sheave of a given diameter and face width. To exceed this speed limit it is recommended that the sheave be dynamically balanced. This information can also be used for pulleys.

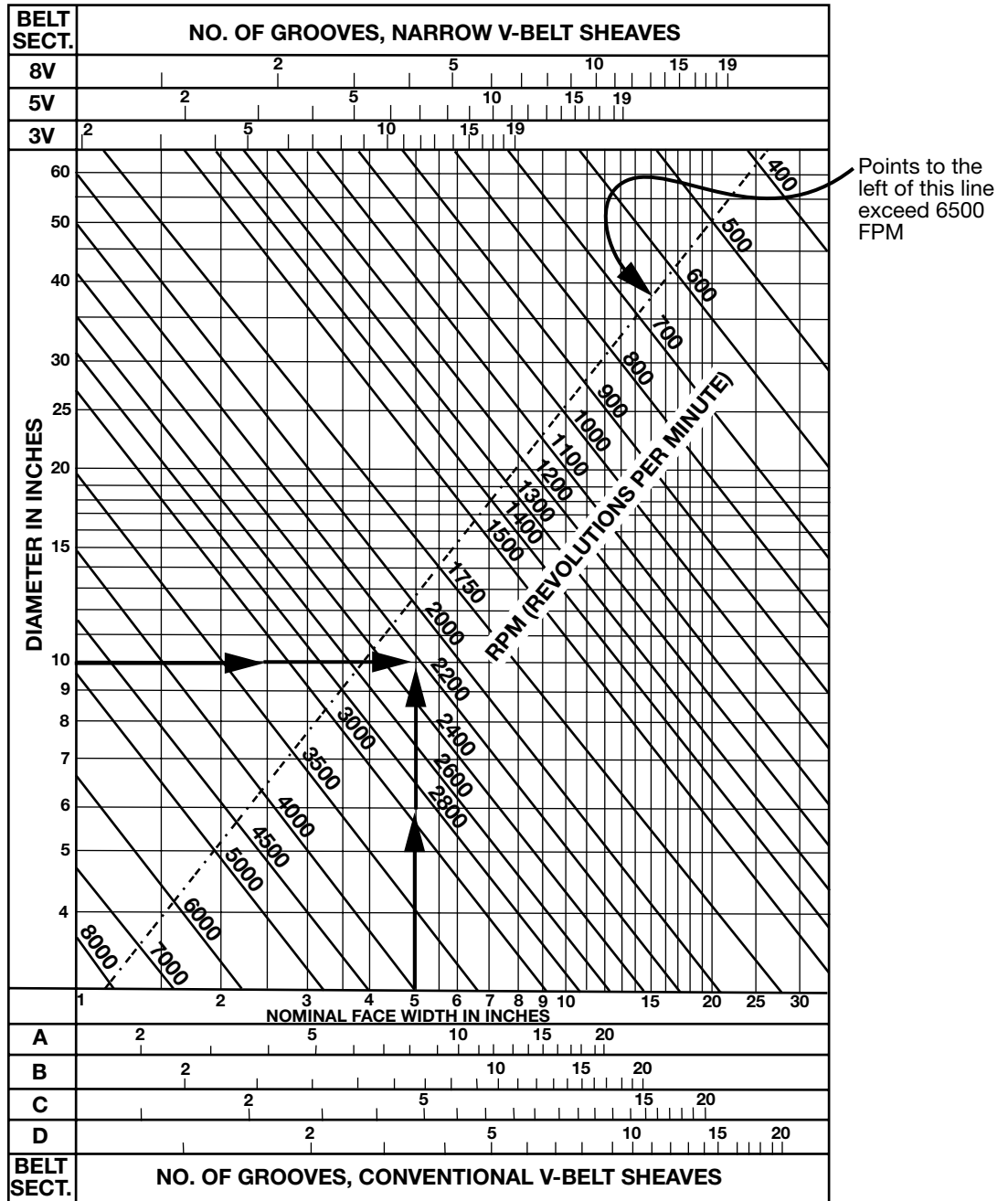

**Example:** A 10" diameter, 5" wide sheave or pulley is recommended to be dynamically balanced (balanced in two planes) at 2250 RPM and above. Below 2250 RPM a static balance (balanced in one plane) is sufficient.

**IMPORTANT:** When belt speeds exceed 6500 feet per minute, special ductile iron sheaves and materials must be used. Consult the manufacturer for special design requirements.

8. Avoid excessive speed-up drives. Speed-up ratios greater than 1.6 can be very difficult to maintain. See discussion below.
9. Avoid synchronous belts. Synchronous belts are tooth or geared belts. They are usually selected because of their high efficiency. They do not slip. However, they are usually noisy. They require a rigid drive mounting support structure and require precise alignment. They usually result in increased vibration and are more expensive.
10. Adjustable pitch drives over 25 horsepower are usually not acceptable. The groove spacing of adjustable pitch sheaves is not very precise. The non-uniform groove spacing creates a tugging action between fan and motor as the sheave rotates. This results in higher vibration and possibly shortens the bearing life. This problem is particularly severe when multi-groove sheaves are required to transmit higher horsepower. ASHRAE's Practical Guide to Noise and Vibration Control recommends limiting adjustable drives to 5 horsepower.
11. The motor should be selected to the following criteria.
  - a. Use a 1200 RPM motor when the fan is running at 300 RPM or less.
  - b. Use an 1800 RPM motor when the fan is running between 301 and 2699 RPM.
  - c. Use a 3600 RPM motor when the fan runs at 2700 RPM and up.
  - d. Check with the motor manufacturer before applying "TS" frame motors with V-belt drives.
  - e. Some fans like tubular fans require a 1200 RPM motor because the fan sheave diameter must be less than the belt tube diameter. Check with the fan manufacturer on the limits for fans with belt tubes.
12. It is the responsibility of the person starting the fan to insure that the belt tension and alignment are correct. Factory settings often get shifted during shipping and installation.

## Larger Horsepower Speed-up Drives

It has been our experience that speed-up drives require higher belt tensions than our drive suppliers specify. This is consistent with some analysis work done by the Gates Corporation in the mid 1980s ("New Method for Analyzing V-Belt Tension," *Machine Design*, July 11, 1985).

On smaller fans with lower horsepower, speed-up drives can be avoided by going to a 3600 RPM motor. However, on larger horsepower, 3600 RPM motors are generally not available. When we have applied 1800 RPM motors we have had field failures consisting of:

1. Very short belt life;
2. Excess heat from the V-belt drive, which gets into the bearing, breaks down the lubricant, and causes bearing failure;
3. Bent shafts from a combination of excessive heat and the resulting breakage of one belt. The broken belt then gets caught between the sheave and other belts, causing excessive loads.

Although it is possible to select components that could transmit the torque acceptably, it is very likely that maintenance personnel will at some time under-tension

the belts. Rapid failure will result.

For these reasons, we have set a maximum speed-up ratio of 1.6 (2800 RPM on a 1750 RPM motor). It is usually possible to select a fan which will avoid excessive speed-up drives.

## Improving the Performance of V-Belt Drives

The following are points that can help improve the performance and extend the useful life of V-belt drives.

1. Prevent belt squeal — This is usually caused by belt slip often due to under-tensioning. Tension belts properly.
2. Correct belt drive tension — Both vertical and lateral vibration occur when the natural frequencies of the drive and belt coincide with the frequency of the fan and motor. Belt tension can affect the amplitude of this vibration. Therefore, to correct the problem first check for proper tension. If this does not work, changing other parameters may reduce the amplitude or alter the frequency. The parameters include span length, belt type, misalignment, and inertia of the driving or driven equipment, pulley diameter and weight, speed and the number of belts. It may be possible to alter the belt's natural frequency so it does not coincide with the frequency of the machinery by downsizing the drive by reducing the number of belts or belt width, and increasing the static tension. To reduce lateral vibration, increase the rigidity in the lateral direction by using joined belts. A wider synchronous belt can increase rigidity but must be tensioned and aligned carefully.
3. Effect of fluids and oils on belts — An occasional spatter of grease or oil does not usually have a negative effect on standard belts. But a large amount will cause a belt to slip. Extensive exposure to oil can also cause the rubber to swell and break down the adhesion between belt components. All stock belts manufactured by members of the Rubber Manufacturers Association are reasonably oil and chemical resistant.
4. Static conductivity of a belt — RMA bulletin IP 3-3 explains how to test for static conductivity by passing an electric current of a specified voltage through a section of belt while measuring the belt's resistance to conduct the current. Most V-belts are manufactured to this standard but to be certain obtain the proper static conductivity from the belt manufacturer. It should have a resistance of 6 M ohm or less to prevent static voltage buildup. This applies to new belts only. With age and exposure to contaminants, static discharge may occur. If this is a consideration, it is important to use a static conductive brush or similar device to bleed off static from the belt. If a belt enables a static charge to build up in a hazardous environment, an explosion may occur. Thus, the environment should be evaluated, and the proper protection should be recommended.
5. Normal belt life — With proper storage, belts can be stored for up to 8 years with no effect on performance. This means that the belt is protected from moisture, temperature extremes, direct sunlight, and high ozone levels. Belts should be hung on a diameter of at least the smallest recommended pulley diameter for that cross section. If the fan stands idle for long periods of time, the tension on the belts should be relaxed. The normal "running"

life of a belt is 24,000 hours or 3 years continuous operation if applied and used properly.

6. Normal temperature range is -30 to +140°F. Tests have shown that for every 36 degrees increase in ambient temperature V-belt life is cut in half. And for every 2°F increase in ambient temperature there is a 1°F increase in the belt's internal running temperature. Thus each 18°F increase in ambient temperature cuts the belt life in half.
7. Causes of heat buildup — When a belt runs, the flexing as it moves around the pulley generates internal heat; external heat is created by slippage between the belt and sheave. The factors that affect temperature include pulley diameter, flexing, load, maintenance (alignment), ambient temperature, and air-cooling. To optimize these effects, use the larger pulley diameters since this reduces internal heat buildup due to small radius bending. This also reduces belt tension and bearing loads, increases airflow, and increases belt contact area. All of this minimizes belt slip and heat buildup. It is good practice to tension belts after a run-in period to ensure proper seating and prevent slippage, which can generate external heat. A good belt guard allows adequate ventilation. Select a flexible belt type to reduce heat buildup. V-ribbed and molded notched V-belts (AX, BX, 3VX, etc.) usually provide good solutions to temperature buildup, especially for small diameter pulleys.
8. Matched belts — RMA standards indicate when belts are considered “matched” (see Table 3 below). For example, all belts in a set that are 100" long must not vary more than 0.30 inches from the longest to the shortest belt. Manufacturing processes have improved so those classical, narrow and molded notched belts now have tighter than RMA tolerances.

Table 3. RMA Standard for Matching V-Belt Lengths

BELT LENGTH (IN.)	RMA TOLERANCE (IN.)	TOLERANCE AS A RATIO OF MAX. LENGTH
Up to 63	0.15	0.0024
63 to 150	0.30	0.0020
151 to 250	0.45	0.0018
251 to 375	0.60	0.0016

9. Bad pulleys — It is always a good idea to check the runout of pulleys with a dial indicator. Experience has shown that there are too many bad pulleys. One result of a bad pulley is excessive vibration. RMA standards are:
  - a. Radial tolerance — Up through 10" outside diameters: 0.010" TIR, add 0.0005" for each additional inch of outside diameter.
  - b. Axial tolerance — Up through 5" outside diameter: 0.005" TIR, add 0.001" for each additional inch of outside diameter.

Figure 4. Groove Gauge

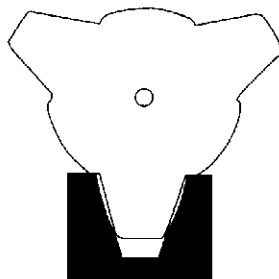

Worn pulleys can be checked visually or with a gauge. It is common to replace sheaves after 3 to 4 belt replacements.

10. Low vibration specifications — Do NOT use variable pitch drives.

## Drive Efficiency

It used to be acceptable to design a belt drive simply by determining the required speed ratio and horsepower, selecting belts and sheaves from a catalog, and finding the lowest price. Today, smart designers fine-tune drives to optimize drive efficiency and keep down both initial and operating costs. Drive efficiency depends on several factors, including load capacity, speed, sheave size, belt flexing resistance and belt tension. Some general rules are:

1. The maximum efficiency is obtained by operating at or very near the belt's rated load capacity. Belt load ratings are calculated and published in tables by the Rubber Manufacturers Association and belt suppliers.
2. Use larger diameter sheaves to increase the belt speed. Larger pulleys reduce flexural stress and require less tensioning force; and
3. Eliminate or control maintenance factors that contribute to energy loss. The most obvious maintenance factor is belt tension. Insufficient belt tension allows belt slip, which reduces speed and performance (horsepower).

## Interchanging U.S. & Metric Standard V-belts

Before substituting, check for dimensional differences in cross sections, length, and belt-rideout (distance a belt extends beyond the sheave OD). For multi-belt drives with joined belts, check for compatibility between belt centers and sheave groove spacing. Even though the specifications indicate interchangeability, a U.S. belt may have a different cross section or length than a comparable metric belt.

## Proper Tensioning of V-belt Drives

Proper tensioning of V-belt drives will make it possible for extended drive life; improper tensioning leads to early failure and can pose a safety hazard as well. A drive tensioned beyond the proper value may shorten belt life, cause excessive vibration, premature bearing failure, and shaft breakage.

### General Method

1. Reduce the center distance so that the belts may be placed over the sheaves and in the grooves. Do not force the belts over the sides of the groove. Arrange the belts so that the top and bottom spans have about the same sag. Apply tension to the belts by increasing the center distance until the belts are snug.
2. Operate the drive a few minutes to seat the belts in the sheave grooves.
3. If any of the following conditions exist, adjust the tension on the belts until they are alleviated.
  - a. The belts squeal as the motor is turned on.
  - b. The belts do not have a slight bow on the slack side when they are operating at full loads (properly tensioned belts will have a slight bow). They could be too loose OR too tight.
  - c. The sheave is excessively hot. With the drive stopped and the safety of the operator insured (turn off power, lock out controls), you should be able to hold your finger in the sheave groove. It will be warm but not too hot to touch.

**Force Deflection Method**

Consult the manufacturer's recommendations for the proper belt deflection. This system involves determining the proper static belt tension, which is checked on the installed drive by measuring the force required to deflect a belt 1/64 inch for each inch of span. A gauge is used to perform this method. Figure 5 shows a typical belt tension gauge.

Figure 5. Typical Belt Tension Gauge

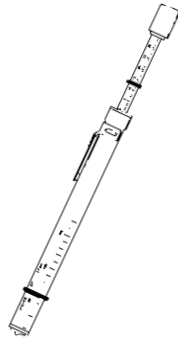

**General Troubleshooting Guide for V-Belt Drives**

PROBLEM	PROBABLE CAUSE	SOLUTION
Short belt life.	<ul style="list-style-type: none"> <li>a. Belt slipping.</li> <li>b. Gouges or extreme cover wear caused by belt rubbing on drive guards or other objects.</li> <li>c. Grease or oil on belt.</li> <li>d. Worn sheaves.</li> </ul>	<ul style="list-style-type: none"> <li>a. Tension belt.</li> <li>b. Eliminate obstruction or realign drive to provide clearance.</li> <li>c. Check for leaky bearings. Clean belt and sheaves.</li> <li>d. Replace sheaves.</li> </ul>
Belts turn over in groove.	<ul style="list-style-type: none"> <li>a. Damaged cord section in belts. Frayed or gouged belts.</li> <li>b. Excessive vibration.</li> <li>c. Sheave misaligned.</li> <li>d. Worn sheaves.</li> </ul>	<ul style="list-style-type: none"> <li>a. Replace belts.</li> <li>b. Tension belts. Replace belts if damaged. Use banded belts.</li> <li>c. Align sheave.</li> <li>d. Replace sheaves.</li> </ul>
Belt squeal.	<ul style="list-style-type: none"> <li>a. Belt not tensioned properly.</li> </ul>	<ul style="list-style-type: none"> <li>a. Tension belts.</li> </ul>
Belt breakage.	<ul style="list-style-type: none"> <li>a. Foreign material in drive.</li> <li>b. Belt damaged during installation</li> </ul>	<ul style="list-style-type: none"> <li>a. Provide belt guard.</li> <li>b. Follow manufacturer's recommendations.</li> </ul>
Belt stretch beyond takeup.	<ul style="list-style-type: none"> <li>a. Worn sheaves.</li> <li>b. Drive excessively tensioned.</li> <li>c. Damaged cord during installation.</li> </ul>	<ul style="list-style-type: none"> <li>a. Replace sheaves.</li> <li>b. Properly tension drive.</li> <li>c. Replace belt and install properly.</li> </ul>
Excessive vibration.	<ul style="list-style-type: none"> <li>a. Damaged belt cord section.</li> <li>b. Loose belt.</li> <li>c. Belts improperly tensioned.</li> </ul>	<ul style="list-style-type: none"> <li>a. Replace belt.</li> <li>b. Tension belt.</li> <li>c. Tension drive with slack of each belt on the same side of drive.</li> </ul>
Belt too long at replacement.	<ul style="list-style-type: none"> <li>a. Wrong size belt.</li> </ul>	<ul style="list-style-type: none"> <li>a. Use shorter belts.</li> </ul>
Belt too short at replacement.	<ul style="list-style-type: none"> <li>a. Wrong size belt.</li> </ul>	<ul style="list-style-type: none"> <li>a. Use longer belts.</li> </ul>



WWW.AEROVENT.COM

5959 TRENTON LANE N. | MINNEAPOLIS, MN 55442 | PHONE: 763-551-7500 | FAX: 763-551-7501

©2018 TWIN CITY FAN COMPANIES, LTD.