

Improvements in Fan Performance Rating Methods for Air and Sound

Introduction

Traditionally, fan manufacturers have tested several sizes of fans out of a product line and used the fan laws to generate ratings for the complete line. The same air and sound performance ratings were used for all arrangements and classes of construction that were offered within the line. It has always been recognized that these product variations would affect the performance. However, as long as the actual performance was within the stated tolerances, the effects of construction variations were ignored.

Several factors have combined in recent years to promote the need for change:

1. The need to improve building efficiency as promoted in the LEEDS program and ASHRAE 90.1 has led to stronger awareness of "as installed" fan efficiency.
2. Fan customers have been pushed to make tighter and tighter guarantees on their equipment, thus increasing the need for tighter accuracy on the fan ratings.
3. The AMCA certified ratings program for fan air performance now allows the manufacturer to certify fan efficiency. Compliance with the efficiency tolerances will require more precise ratings than current methods.
4. A recent article in the November 2005 issue of the *ASHRAE Journal* suggests that fan manufacturers should be testing more samples to establish their ratings.
5. The accuracy of sound power ratings is becoming increasingly important.

Improvements in Adjusting for Fan Arrangements

A fan commonly used in air handling units is the airfoil bladed plenum fan. Its efficiency, combined with compact size and versatility in duct take-offs, have made it ideal for many applications. There are three common arrangements that manufacturers may offer:

Arrangement 1: This has a pedestal that supports two bearings. The fan impeller is over-hung on one side and the fan sheave is mounted on the opposite end.

Arrangement 3: This arrangement has one bearing mounted in the inlet side and the other bearing on the backside of the fan impeller. The impeller is thus center-hung. The fan sheave is normally mounted on the shaft extension, which protrudes through the rear bearing.

Arrangement 4: The fan impeller is mounted directly on the motor shaft. There is no fan shaft or fan bearings.

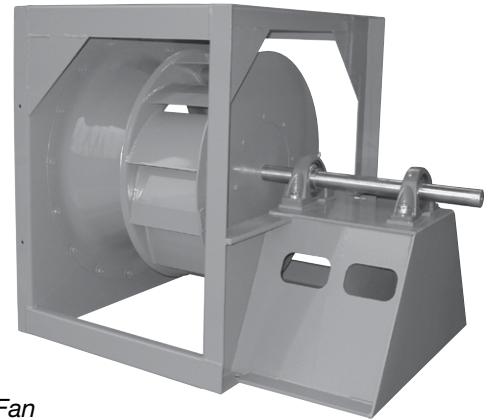

*Arrg. 1
Plenum Fan*

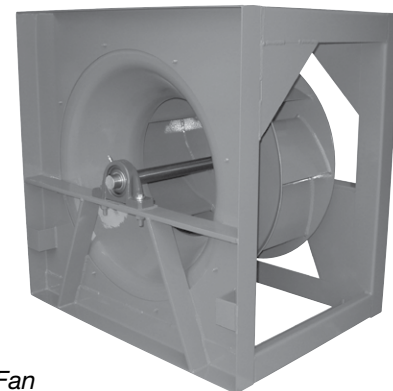

*Arrg. 3
Plenum Fan*

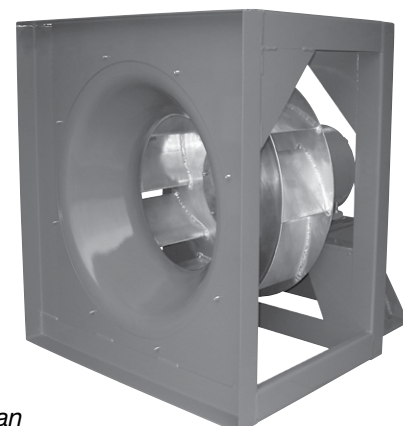

*Arrg. 4
Plenum Fan*

The Arrangement 4 has no obstruction in the inlet, and no bearing drag loss to incorporate and therefore will have the best efficiency. A close second is the Arrangement 1 fan, which also has the open inlet, but includes the bearing drag losses. The lowest efficiency is the Arrangement 3 fan, which typically has a pillow block bearing as well as its support structure directly in the high velocity inlet air. This causes increased aerodynamic losses. It also has the bearing drag loss.

It was common for fans that were offered both in Arrangements 1 and 3 to use the Arrangement 1 for rating purposes. It gave higher efficiencies than Arrangement 3, and if all manufacturers used the same methods, the results were comparable. However, the Arrangement 3 fan could actually be 5-10 percent lower in efficiency. This difference has become important when considering the developments discussed above. Manufacturers can and are responding to the current situation by having separate AMCA certified ratings for the fans that have the bearings in the inlet (Arrg. 3) versus those that do not (Arrg. 1 and 4). While this increases the time and expense required to get new products to the market, it provides more accurate ratings required by air handling equipment manufacturers who utilize the Arrangement 3 fans. It should be noted that Arrangement 3 has a cost advantage in that it has a smaller footprint along the axial direction.

Another common fan used in air handlers are airfoil, double width fans that use scroll type housings. Since these are only offered in the Arrangement 3 configuration, the performance ratings of different manufacturers should be comparable. The only change anticipated on this fan line to improve rating accuracy is to test more sizes. This is to allow for the fact that there are some "size effects" that the fan laws do not predict.

Arrg. 3
DWDI Fan

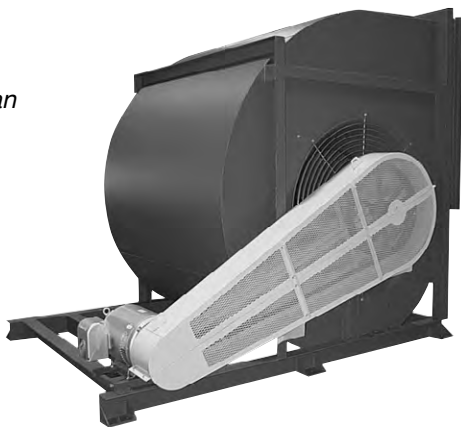

Considerations of Fan Class of Construction

The fan class determines the maximum allowable operating speed of the fan. In the higher classes, the materials of construction may be changed to stronger, thicker or more heavily reinforced construction. In very high speed construction, fan manufacturers can use higher cost, high strength steels or they may choose to add blade reinforcing rings. These may be segmented gussets that are welded to the blades near the mid-span of the blade, or they could be a continuous ring.

While it is possible to make airfoil fans to generate high pressure without reinforcement rings, some manufacturers

do not do this. A blade reinforcement ring can also degrade fan performance substantially, but this may not be reflected in the performance ratings of some manufacturers.

The Impact of Fan Accessories

Just as the accessories installed on a car can affect gas mileage, fan accessories can affect fan efficiency and sound. Some common fan accessories are as follows:

1. Inlet screens: These will affect performance and their loss is normally not accounted for in the ratings. Some air handling manufacturers avoid inlet screens by use of electrical interlocks in the doors. These require the fan power to be cut prior to accessing the unit interior.
2. Protective Enclosures: These enclose the fan impeller and have a high percentage of open area to reduce losses. A good design will have minimal effect on performance and its effect can be ignored. Welded heavy wire performs best, but non-flattened expanded metal also has minimal losses.
3. Flow Measurement Tubes and Probes: When mounted in the throat of the inlet cone, these can have dramatic losses. Do not use for optimum efficiency. Consider the use of the piezometer style flow measurement, which has no loss.



Flow tubes in inlet (left) create large losses, whereas a piezometer ring (below) has no loss.

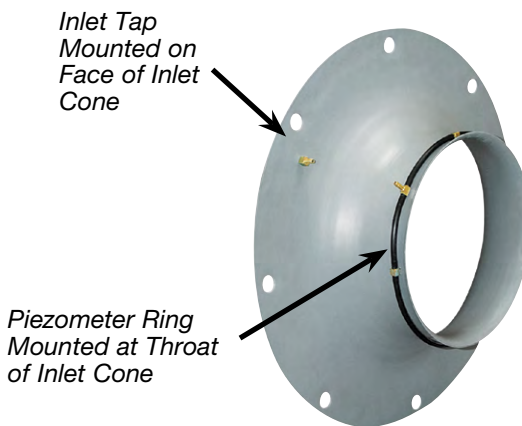

4. V-belt Drives: Plenum fan and airfoil double width fans do not include V-belt drive losses. Do not over-specify V-belt drives. Service factors from 1.3 to 1.5 will always provide good life on these types of fan. Specifying "two-groove minimum" on fans five horsepower and smaller can be counter-productive to reliability and can waste a large percentage of the power. AMCA 203: "Field Performance Measurement of Fan Systems" shows a table for estimating V-belt drive losses that works well for normal service factors.

5. Inlet Vanes: The purpose of the inlet vane is to change the performance in a controlled manner. However, there are also losses with the vane fully open that the fan manufacturer can correct for in their published performance. The popularity of inlet vanes has declined due to the wide acceptance of inverter driven motors.
 6. Inverter driven motors (VFD): Fan users should be aware that VFDs induce two types of power losses that are often overlooked due to sparse data from the manufacturers. The inverter itself has electrical losses that result in heating of the inverter. Also, since the output of the inverter is not sinusoidal, there is a loss of motor efficiency. Some motor manufacturers state that a motor with a 1.15 service factor will have a 1.0 service factor when inverter driven. At the time of this writing, there is no motor industry standard to allow motor manufacturers to publish these losses in a uniform manner.
 7. Most other accessories will not affect performance to a significant degree. Up-sized bearings will have slightly higher bearing drag. Belt guards on plenum fans have minimal effects if driven from the “back” (opposite inlet) side.
3. Specify that no blade rings should be used or make inquiries to the manufacturer on their use of blade reinforcing rings, and whether the ratings are adjusted for the rings.
 4. Some air handling manufacturers use a variety of fan arrangements in their designs. A fan manufacturer that can provide accurate AMCA certified ratings in all arrangements will simplify fan selection and assure design and data integrity.
 5. Consider the impact of accessories on fan performance and avoid those that cause significant losses.

Recommendations for Fan Users

1. Where an Arrangement 3 fan is being used, specify that the fan air, inlet and outlet sound ratings must be AMCA certified from Arrangement 3 tests. Some manufacturers may provide derate factors, but these are not likely certified and are of questionable accuracy.
2. When comparing ratings between manufacturers, make sure that all fans are of like construction. Comparing an Arrangement 3 performance from one manufacturer to an Arrangement 1 of another will lead to the wrong conclusions.

Additional Observations and Conclusions

Fan users' requests for better precision in fan ratings are forcing responsible fan manufacturers to perform a great deal more testing. A primary impetus of this is to know more accurately the fan efficiency for all variations of fan design. A side benefit of this is that all fan samples are also tested for sound. It has been found that the bearing mounted in the inlet also affects the sound ratings and these should be rated separately. Unless the fans are perfectly symmetrical, inlet sound power and outlet sound power are not equal. Therefore, these should be rated separately.

Intelligent comparisons of fan ratings involve “digging into” the details. Users should know the configuration of the fans used for ratings and whether any blade reinforcement is used that is not accounted for in the ratings. Finally, be aware that the use of fan accessories can affect performance. Accessory effects can be minimized by effective design.

Although it is possible to certify fans for efficiency, at the time of this writing, no manufacturers had done so. If this has value to fan users, they should work with the manufacturers to encourage them to adapt this added assurance of accurate ratings.



WWW.AEROVENT.COM

5959 TRENTON LANE N. | MINNEAPOLIS, MN 55442 | PHONE: 763-551-7500 | FAX: 763-551-7501

©2018 TWIN CITY FAN COMPANIES, LTD.