

General Installation, Operation and Maintenance Instructions For Aerovent Products

Throughout this manual, there are a number of NOTICE statements that must be read and adhered to.

NOTICE

Indicates information considered important, but not hazard-related.

It is the responsibility of all personnel involved in installation, operation and maintenance to fully understand the Notice procedures by which hazards are to be avoided.

Installation

1. Install the door heater in the position required. Dimensions can vary to suit door opening. Heaters can be mounted in horizontal, angular or vertical position. Do not mount with the control box upside down or on the bottom. Weight of the unit is approximately 375 lbs.

NOTICE

Negative pressure in the building will have an affect on the unit's ability to maintain an air curtain effect. This should be taken into account when locating the unit.

2. Connect electrical power. If the unit does not have a built-in disconnect switch, then an external disconnect should be provided by the installer. Be sure power supply is the proper voltage. These units are furnished for specified voltage.
3. Connect the gas supply line using the regulator furnished with the unit. Consult your gas company service representative to determine the proper size for the gas line. This varies according to the pressure and length of the run. Required gas input can be determined by the chart, Fig. 1.

NATURAL GAS MODEL NO.	INPUT BTU	NOMINAL TEMP. RISE	GAS PRESS.	
24S728 NDH	325,000	73°F	1 oz.	1.75" w.c.
	440,000	99°F	2 oz.	3.50" w.c.
	580,000	131°F	3 oz.	5.25" w.c.
24S728 NDH	440,000	66°F	2 oz.	3.50" w.c.
	580,000	85°F	3 oz.	5.25" w.c.
	680,000	102°F	4 oz.	7.00" w.c.
2 HP	790,000	118°F	5 oz.	8.75" w.c.
	870,000	130°F	6 oz.	10.50" w.c.
	990,000	148°F	7 oz.	12.25" w.c.

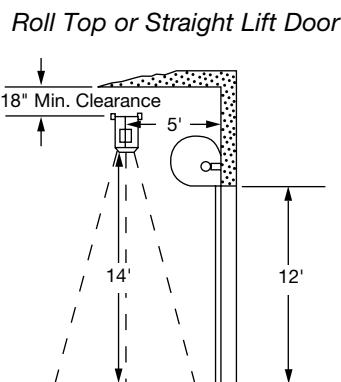
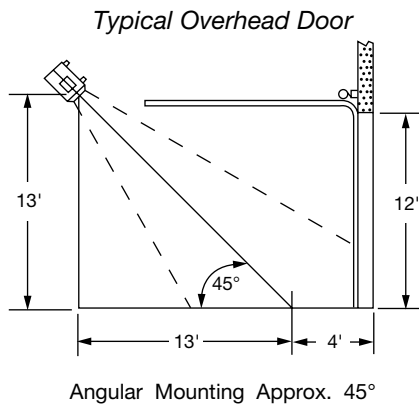

Vertical Mounting Used With Roll Top Doors

Fig. 2. Operating Station

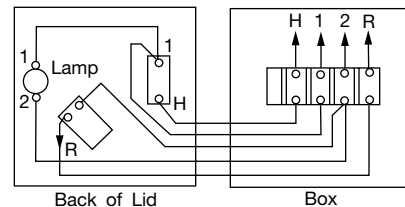

Connect H, 1, 2, and R to terminal strip in unit control box.

Fig. 3. Operating Station with Optional Hi-Lo Fire

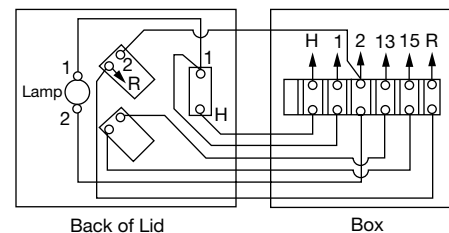

Connect H, 1, 2, R, 13 and 15 to terminal strip in unit control box.

4. Mount the operating station in a convenient location and make connections to the terminal strip in the unit as indicated in Fig. 2, or Fig. 3 for units supplied with the optional high-low fire feature.
5. Mount the door switch so it will trip to close the circuit when the door is open. The switch may be located so the heater will come on when the door starts to open or when fully open at the discretion of the user. See typical suggested installations.

Door Switch and Suggested Installations

The door switch may be installed with the switch in the "free" position when the door is either opened or closed. If the switch is mounted so that it is in the "free" position when the door is open, use the normally-closed circuit, terminals #1 and #2. If the switch is mounted so that it is in the "free" position when the door is closed, use the normally-open circuit, terminals #3 and #4.

Installation #1: Floor Level Location - Switch is in "free" position when the door is open. Use switch terminals #1 and #2. Heater will fire when the door starts to open.

Installation #2: Overhead Location - Switch is in "free" position when the door is closed. Use switch terminals #3 and #4. Heater will fire only when the door is completely open.

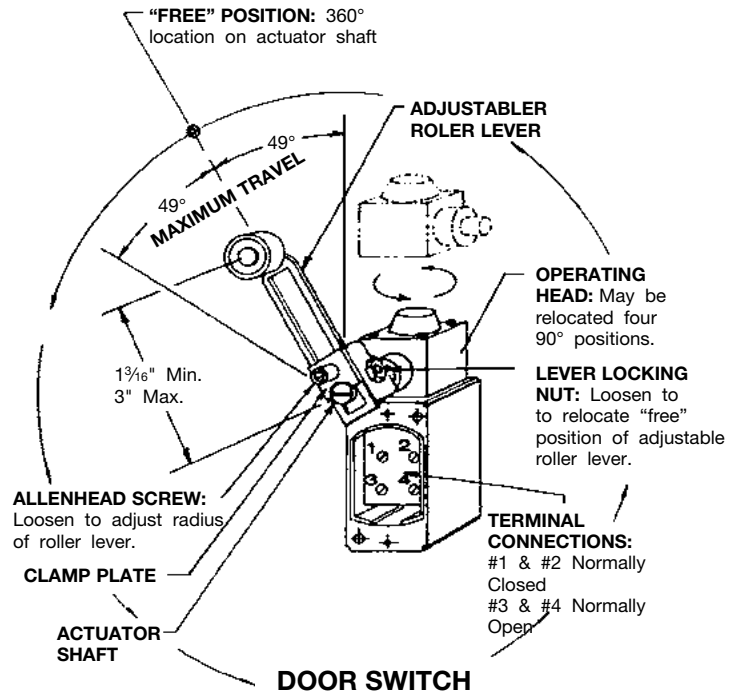

Installation #3: Overhead Location - Switch is in "free" position when the door is open. Use switch terminals #1 and #2. Heater will fire when the door starts to open.

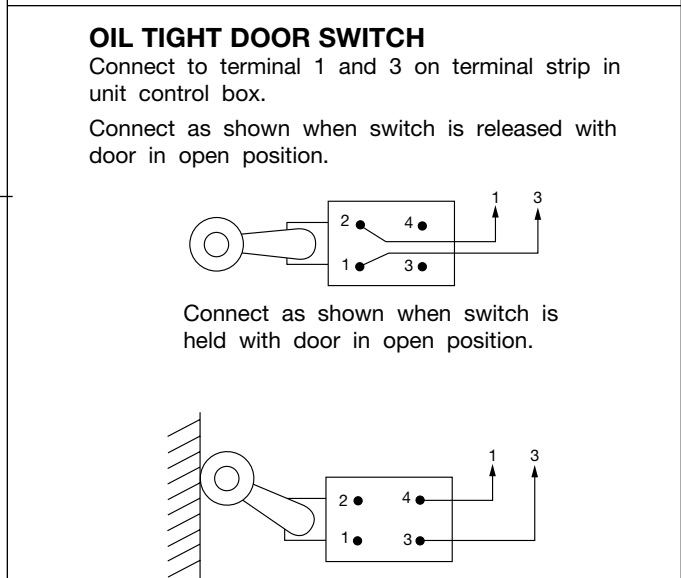
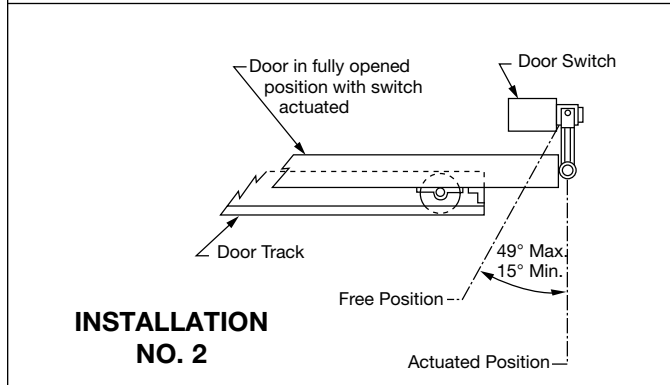
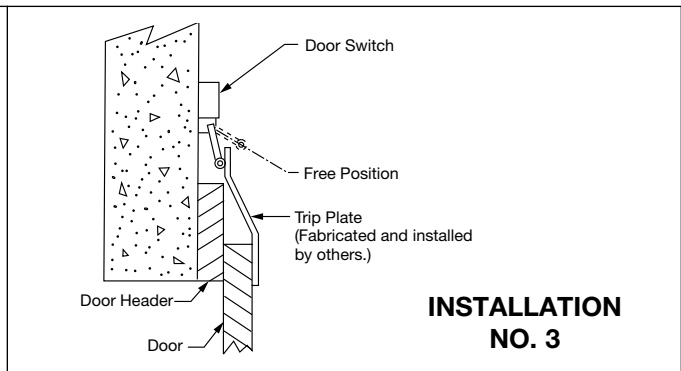
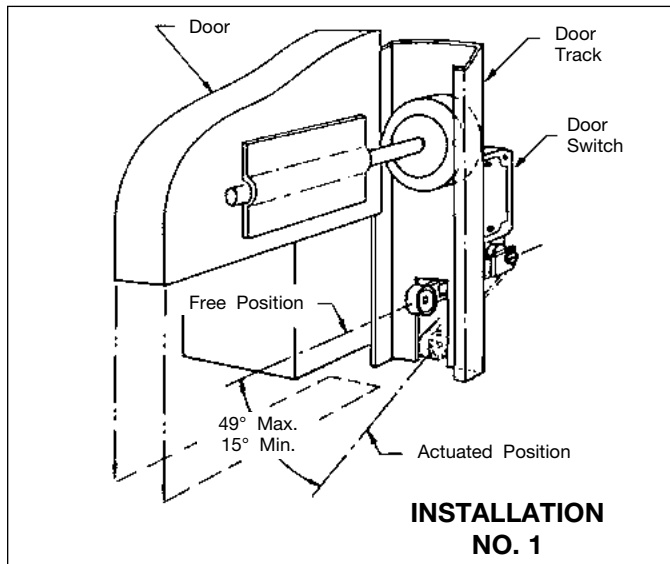

Standard Wiring and Piping Sequence of Operation

The unit can be operated manually with an on-off switch in remote station or automatically from a door switch on an overhead door. Normal operation is to leave the on-off switch "on" and cycle the unit with the door switch as the overhead door on the dock opens and closes.

Door opening closes the switch between terminal #1 and #3; the fan starts. Interlock (E) on the fan starter (FSR) closes the circuit between terminal #6 and #7. An electrical circuit is made to terminal #7 through the high gas pressure switch (C) and airflow switch (D). Power on terminal #7 will cause the primary combustion relay (RM7890) to pull in. Ignition occurs powered from terminal #9, main gas valves open powered from terminal #11.

Flame is proven through the flame rod and the RM7890 primary relay allows power to energize terminal #10 and de-energizes terminal #9 dropping out the ignition transformer.

If discharge temperature exceeds 200°F, high limit (A) between terminals #10 and #11 will open which de-energizes the gas valves. Loss of flame will cause combustion relay to lock out requiring manual reset on IRI/FM single valve and FM valve. The standard unit will try to restart on flame loss.

The sequence of operation is similar for IRI/FM and FM units. For schematic wiring, see the following reduction drawings:

Standard	R26871-00
FM	R26870-00
IRI/FM	R26869-00
All Piping Diagrams . . .	R26872-00

Troubleshooting

1. Switch the on-off toggle switch to the "ON" position in remote station. The indicator light should come on. If not, check the power supply to the unit, the fuse between H and XI or the bulb to see if it has burned out.
2. Close the door switch between terminal #1 and #3. The fan should start. If not, check overload on the motor starter (manual reset) when the fan starts auxiliary contact between terminal #6 and #7 closes. You should have 120 volts to terminal #7 (flame relay). If not, check the high gas pressure switch (manual reset) or the airflow switch. The high gas pressure switch should be set at 21.0". The airflow switch should be set at 1.0".
3. When the flame relay has power to terminal #6, it will go through a self-checking cycle and then power wire #9 from terminal #10, turning on the ignition transformer and wire #10 from terminal #8, opening the main valves. If ignition (spark) is occurring but valves do not open, check the high limit between terminal #10 and #11. High limit should be set at 200°F. If spark is not occurring, check the spark plug. The gap should be 0.072 and the electrode should be clean (no carbon). If the flame relay has power to it but flame cycle will not occur, reset the flame relay (manual reset). If flame comes on momentarily and goes out, check

the flame rod. There should not be any cracks in the porcelain. The flame rod senses current in the flame. To check if it is functioning, plug a voltmeter into the amplified module. The unit should be 0-5 volts D.C. (On older units equipped with RA890F, a test jack is beside the red reset button and the unit should be minimum 2 microamps. Normal range is 2-5 microamps.)

4. FM and IRI/FM units work the same as standard with the exception that they have a pilot which lights before the main flame comes on. If the pilot does not light, check to see that the 1/4" pilot valve is opening, the pilot gas line is not obstructed or the pilot assembly in the burner is intact. Also, there is a timer to turn the pilot off after the burner lights which should be set at approximate 5 seconds. Check the timer to make sure it is functioning.
5. Some units are supplied with a UV scanner (mini-peeper) rather than a flame rod. Flame current check should yield the same results as a flame rod: 0-5 volts D.C. (on older units equipped with RA890G flame relay, flame current should be minimum 1.5 microamps).

For additional troubleshooting guidance, refer to RM7890A1015 bulletin.

High-Low Fire Option

Units ordered with the high-low fire option are supplied with a 1" NPT SR600 two-stage valve mounted in the pipe train.

The SR600 provides an economical means of flame staging where infinite modulation is not required. Turn-down on low-fire is from 25% to 75% of high-fire. This valve is powered by a 24 volt AC transformer. When the coil is energized, the valve is at low-fire. When the coil is de-energized, it is at high-fire.

Adjustments

To check the minimum or low-fire and maximum or high-fire pressures for the limits of modulation or staging, use the following procedures:

To set minimum or low-fire:

1. Remove the cover plate **1**.
2. Remove the high fire adjusting screw **2**, spring **3** and plunger **4**. A small magnet is useful for this purpose. Handle the plunger carefully to avoid marring or collecting dirt. Do not lubricate.
3. Modulation or Staging: Using the low-fire adjusting screw **5**, set the manifold pressure to the manufacturer's specifications (50% to 75% of high-fire).
4. Modulation or Staging: Cycle the solenoid gas valve to check for proper ignition.
5. Modulation or Staging: Adjust the air shutter or increase low-fire adjustment if needed.
6. Replace the plunger, spring and high-fire adjusting screw.

To set maximum or high-fire:

NOTICE

To avoid danger of over-firing, make certain that the inlet pressure is at 1.0" w.c. above the outlet pressure.

1. Modulation and Staging: Using the high-fire adjusting screw **2**, set the manifold pressure to the manufacturer's specifications. See page 1, Fig. 1.
2. Staging Only: Cycle the burner to check performance.
3. Replace the cover plate.

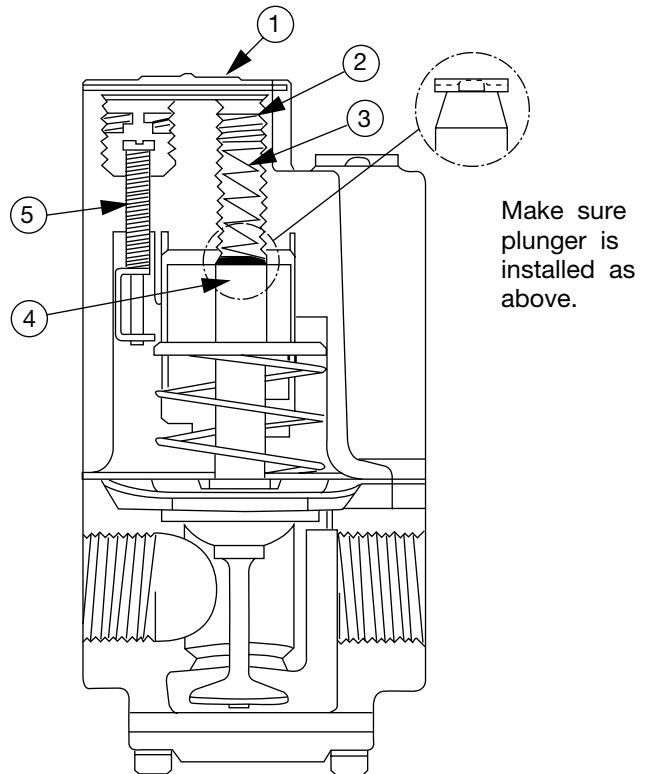

WWW.AEROVENT.COM

5959 TRENTON LANE N | MINNEAPOLIS, MN 55442 | PHONE: 763-551-7500 | FAX: 763-551-7501