



Electronic commutation (EC) is the latest motor technology to be used in direct drive fans. Also known in the industry as Brush Free or Brushless DC, the EC motors utilize an electronic circuitboard to control the functionality of the motor. The motor operates off of 115V or 208/230V AC single phase power or 208/230V or 460 three phase power, which is converted to DC power within the motor’s circuitry. The result is a highly efficient motor with an expanded speed control range and a variety of speed control options to choose from.



Model ACXD
with EC motor



REVIEW AMCA BULLETIN 410 PRIOR TO INSTALLATION

This bulletin has been prepared to guide the users of electronically commutated motors in the proper installation, operation and maintenance procedures to ensure maximum equipment life with trouble-free operation. For safe installation, startup and operational life of this equipment, it is important that all involved with the equipment be well versed in proper fan safety practices and read this bulletin. It is the user’s responsibility to make sure that all requirements of good safety practices and any applicable safety codes are strictly adhered to. Because of the wide variety of equipment covered in this bulletin, the instructions given here are general in nature. Additional product and engineering information is available at www.aerovent.com.

SAFETY NOTICE

Refer to the safety section(s) in this manual prior to installing or servicing the fan. The most current version of this installation and maintenance manual can be found on our website at www.aerovent.com/resources/installation-maintenance-manuals.

TABLE OF CONTENTS

| | |
|--|-----|
| Safety & Hazard Warnings | 2 |
| Shipping & Receiving | 2 |
| Handling | 3 |
| Unit Storage | 4 |
| General Installation..... | 4 |
| Electrical Connection..... | 5 |
| Speed Control Options: EC-ODP & EC-TENV Motors | 5-7 |
| Speed Control Options: EC-TEFC Motors | 8-9 |
| Speed Control Options: EC-OP Motors | 10 |
| Maintenance | 11 |
| Troubleshooting..... | 11 |

SAFETY & HAZARD WARNINGS

For general safety practices for air moving equipment, see AMCA Bulletin 410. Aerovent offers many safety accessories. These safety devices include (but are not limited to) belt guards, shaft guards, inlet and discharge screens. The use and suitability of safety devices is the responsibility of the purchaser.

Facility-related safety conditions include the fans' accessibility and location. How easily can non-service personnel access the unit? Is the fan in a hazardous duty environment? Was the unit ordered for this duty? Other concerns must also be addressed. All fans should be powered through switches which are easily accessible to service personnel from the fan. Fan power must have the ability to be "locked out" by service personnel trained in lockout/tagout procedures per OSHA requirements (29CFR1910.147). When performing lockout, be aware of factors, such as building pressure and additional fans in the system that can influence unwanted fan rotation (wind milling). If you have any doubt about your ability to perform a task, seek a person qualified to do that task. Before any work is done on a fan, ensure that the fan is isolated from the electrical supply using a 'lockout/tagout system.'

Note: A stationary, non-rotating fan does not mean that the fan is isolated from the electrical supply. A non-rotating fan could be subject to controls or other circuit protection devices that may start the fan without notice.

The following safety precautions should be followed, where applicable:

- Do not attempt to slow a rotating impeller even when it is isolated from the electrical supply. Fan impellers have a high inertia and injury could result from an attempt to stop it. It is recommended that the impeller is isolated by closing off the inlet or outlet to prevent wind-driven rotation. If an impeller is chocked to prevent rotation, ensure that the chocks are removed prior to start up.
- Wear appropriate personal protective equipment. This may include protective clothing, eye protection, ear protection, respiratory equipment, hand and foot protection when installing or servicing the fan.
- Always use caution when entering a fan's air path. High velocity airflow can cause you to lose your balance.
- Motors can be hot, and similarly if the fan is subject to processes that are hot, the fan housing could be hot.
- Fans are often used to move hazardous materials that could be dangerous. Always wear protective clothing and take precautions not to inhale dust/gases. If hazardous chemical vapors are present, respiratory equipment may be required.
- Sharp edges – wear protective gloves when handling, installing, or servicing a fan.
- Fans can operate at high decibel sound levels. Wear proper ear protection to protect from excessive noise levels.
- Access Doors – Do not open access doors when fan is in operation. The effects of suction and air pressure could result in injury.
- When working around pulleys and belts, keep hands away from pinch points. This pertains to when the fan is under or off power.

Throughout this manual, there are a number of HAZARD WARNINGS that must be read and adhered to in order to prevent possible personal injury and/or damage to equipment. Two signal words "WARNING" and "CAUTION" are used to indicate the severity of a hazard and are preceded by the safety alert symbol. It is the responsibility of all personnel involved in installation, operation and maintenance to fully understand the warning and caution procedures by which hazards are to be avoided.

 **WARNING:** Used when serious injury or death MAY result from misuse or failure to follow specific instructions.

 **CAUTION:** Used when minor or moderate injury or product / equipment damage MAY result from misuse or failure to follow specific instructions.

NOTICE: Indicates information considered important, but not hazard-related.

SHIPPING & RECEIVING

All Aerovent products are carefully constructed and inspected before shipment to insure the highest standards of quality and performance. Compare all components with the bill of lading or packing list to verify that the proper unit was received. Check each unit for any damage that may have occurred in transit. Any damage should be reported immediately to the carrier and the necessary damage report filed. Damage should be noted on the bill of lading.

HANDLING

Handling of all air moving equipment should be conducted by trained personnel and be consistent with safe handling practices. Verify the lift capacity and operating condition of handling equipment. When using hoisting equipment, only qualified and trained personnel should operate the equipment.

Units shipped completely assembled may be lifted with slings and spreader bars. (Use well-padded chains, cables or nylon straps, rated to lift the required weight.) On most units, lifting lugs are designed to protect the fan and fan housing from damage. Never lift a fan by the inlet or discharge flange, wheel or propeller, motor or motor base, or in any other manner that may bend or distort parts. Never lift with slings or timbers passed through the fan inlets.

For fans provided without lifting lugs, use a forklift or pallet jack to handle the equipment. Consult a qualified person before lifting.



CAUTION

1. Maintain handling equipment to avoid serious personal injury and do not stand under the load.
2. If supplied, only use the provided lifting lugs to lift the equipment.
3. Ensure that the lifting equipment is rated for the capacity to be lifted.

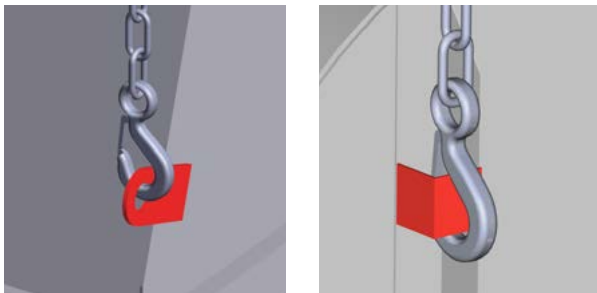

Lifting lugs are provided on most units.

Lift fans as shown



Partial or disassembled units require special handling. All parts should be handled in a method which protects the coatings and parts from damage. Components should be handled such that forces are not concentrated to avoid bending or distortion.

The housing should be lifted using suitably rated spreader bars and padded chains or straps. Do not distort housing or side plates when lifting.

Never lift or support the assembly by the wheel. See the Fan Installation section for additional details.

Wheels shipped separately can be lifted by slings running between the blades or through the hub. Never lift the wheel by a single blade or single point on the flange/shroud. Do not put a chain within the hub bore. Always transport wheels by lifting, do not roll the wheel as this can damage coatings and change the balance of the wheel.

UNIT STORAGE

If fan installation is to be delayed, store the unit in an environmentally stable and protected area. During storage, the fan should not be subjected to vibration from external sources or bearing damage may occur. The unit should be reasonably protected from any accidental impacts. Cover the fan to protect coatings and to prevent any foreign material or moisture from entering the inlet or discharge. Take care to protect the motor.

Extended storage requires monthly inspections. Check for corrosion or damage to the unit and for debris within the fan.

Motors should be stored in a clean, dry and vibration-free location. The packaging should be opened up enough to allow air circulation around the motor. The winding temperature should be kept slightly above that of the surroundings to prevent condensation. This can be accomplished by energizing the internal heaters, if the motor is so equipped, or by using space heaters. If it is impossible to heat the windings, the motor should be wrapped tightly with a waterproof material which also encloses several bags of desiccant. Replace the desiccant regularly to prevent moisture problems. The motor rotor should also be rotated regularly (monthly) to assure the bearing parts are well greased. Consult the motor manufacturer for further detail on motor storage and start up after longer periods of storage. It may be necessary to regrease the bearings.

GENERAL INSTALLATION

| |
|---|
|  CAUTION |
| <ol style="list-style-type: none"> 1. Sheet metal parts, screws, clips and similar items inherently have sharp edges, and it is necessary that the installer and service personnel exercise caution. 2. Surface temperatures of motor may reach temperatures which can cause discomfort or injury to personnel accidentally coming into contact with hot surfaces. When installing, protection should be provided by the user to protect against accidental contact with hot surfaces. Failure to observe this precaution could result in bodily injury. 3. This equipment contains voltages that may be as high as 1000 volts! Electrical shock can cause serious or fatal injury. Do not touch any circuit board, power device or electrical connection before you first ensure that the power has been disconnected. Always disconnect, lock and tag power source before installing or servicing. Failure to disconnect power source can result in fire, shock or serious injury. |

The installation of this equipment shall be in accordance with the regulations of authorities having jurisdiction and all applicable codes. This equipment is to be installed by an experienced installation company and fully trained personnel.

Verify that the wheel rotation is correct. It should be CW when viewed from the shaft end (CCW from opposite shaft end).

Refer to IM-121, IM-167 or IM-172 for detailed installation instructions on the fans that utilize EC motors.

Do not operate the fan beyond the maximum cataloged RPM. The current should be verified any time the RPM is adjusted to ensure it is below the nameplate amperage value.

| |
|---|
|  WARNING |
| <p>Pacemaker danger – Magnetic or electromagnetic fields in the vicinity of current carrying conductors and permanent magnetic motors can result in a serious health hazard to implants and hearing aids. To avoid risk, stay away from the area surrounding a permanent magnet motor.</p> |

ELECTRICAL CONNECTION

1. Connect supply wiring to the disconnect switch (non-fused standard).
2. The motor is factory set at the voltage marked on the fan nameplate. Check the line voltage with the nameplate voltage.
3. The main power wiring should be sized for the ampacity shown on the dataplate. Size wires in accordance with the ampacity tables in Article 310 of the National Electrical Code. If long wires are required, it may be necessary to increase wire size to prevent excessive voltage drop. Wires should be sized for a maximum of 3% voltage drop.
4. Disconnect switches are not fused. The power leads must be protected at the point of distribution in accordance with the fan dataplate.
5. All units must be electrically grounded in accordance with local codes or, in the absence of local codes, with the latest edition of the National Electrical Code (ANSI/NFPA 70). A ground lug is provided as standard in the unit terminal box. Size grounding conductor in accordance with Table 250-95 of the National Electrical Code. DO NOT use the ground lug for connecting a neutral conductor.
6. Supply voltage to the power ventilator should not vary by more than 10% of the value indicated on the unit dataplate. Phase unbalance must not exceed 2%.

CAUTION

1. Use copper conductors only.
2. Protect wiring from sharp edges. Leave some slack in the line to prevent damage. Do not allow the power or speed control cables to kink or come in contact with oil, grease, hot surfaces or chemicals. If damaged, discontinue use immediately and have cord replaced. Use proper strain relief.

SPEED CONTROL OPTIONS: EC-ODP & EC-TENV MOTORS

This section covers the motors listed in the chart on the right.

Three speed control options are available for the Aerovent EC motor. Coming standard with the motor is both a motor mounted dial, for speed adjustment at the fan (first option), and a 0-10V DC control lead. The 0-10V DC control lead can be used with a remote speed control, either field supplied (second option) or supplied by Aerovent (third option).

1. **Motor Mounted Dial (Standard Feature)** – A potentiometer is mounted to the motor housing offering full speed control range. Speed adjustment is made with a small flat head screwdriver. With this option, the motor’s 0-10V DC control leads are terminated in a standard 2x4 junction box from the factory and can remain there if not required by the end user.

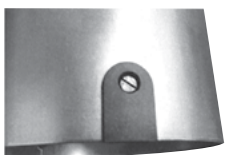

2. **0-10V DC Lead (Standard Feature)** – A 36" long control lead is prewired from the motor which accepts a 0-10V DC signal and can be wired into building control systems or field supplied controls. With this option, the control leads are terminated in a standard 2x4 junction box from the factory.

| Aerovent Part Number | Manufacturer's Part Number | HP | Voltage/Phase |
|----------------------|----------------------------|-----|---------------|
| 67001001 | F2216B4286 | 1/4 | 115/1 |
| 67001003 | F2232B4287 | 1/2 | 115/1 |
| 67001004 | F2240B4288 | 3/4 | 115/1 |
| 67001005 | F2256B4289 | 1 | 115/1 |
| 67001008 | F2212B4494 | 1/6 | 115/1 |
| 67001105 | F2280B4385 | 1 | 115/1 |
| 67002101 | F2216A4273 | 1/4 | 208-230/1 |
| 67001103 | F2232B4495 | 1/2 | 208-230/1 |
| 67001104 | F2240B4496 | 3/4 | 208-230/1 |
| 67001015 | F2256B4497 | 1 | 208-230/1 |
| 67001115 | F2280B4493 | 1 | 208-230/1 |

CAUTION

Always disconnect power before inspection or maintenance. Although motor may be off and not running when a 0-1.9V DC signal is present, high voltage will still be present at the motor.

Field supplied controllers should be provided and installed by others and send the motor a 0-10V DC signal. A 24V AC or DC source is also required to power the controls in the motor. Note that the motor mounted dial acts as a speed reference for this option. In order to have the full speed control range available for a given fan/motor combination, the motor mounted dial must be turned all the way in the CW direction or to the maximum RPM allowable for the fan/motor combination (look for labels on fan). The motor operates off of a 2-10V DC signal while the motor will be off when a 0-1.9V DC signal is present. **It is the responsibility of the installer/controls engineer to ensure that any field supplied controls are compatible and functional with this motor technology. Aerovent is not responsible for field supplied or customer designed fan or motor controls.**



SPEED CONTROL OPTIONS: EC-ODP & EC-TENV MOTORS (CONT.)

3. **Remote Mounted Dial (Optional Feature)** – A wall mounted dial allows the fan to be controlled from within the building by sending the motor a 0-10V DC option. This option includes a 115V or 230V (depending upon the motor voltage selected) to 24V AC transformer mounted in the NEMA electrical enclosure. On models ACXD, ATD/R and ATDW/R the junction box for the transformer will be located within the fan motor enclosure/weather cover. On model SCDD, the junction box for the transformer will be located on the exterior of the fan.



With this option a 3 wire control cable must be field supplied and wired from the 24V AC transformer box to the remote location of the controller. In addition, a standard 2x4 single gang electrical junction box (by others) is required to mount the controller. The maximum distance from the remote mounted controller to the motor is 100 feet. Distances greater than this could cause a loss of the signal to the motor and result in unstable motor performance.

On the back of the remote mounted dial there is a small switch which will allow the user to change the output of the remote mounted dial. The settings of the switch are 0-10V or 2-10V. A label on the rear of the controller's printed circuitboard describes the settings. The motor will run regardless of which setting the dial is at, but because the motor operates off of a 2-10V DC signal, it will be off when a 0-1.9V DC signal is present. If the user requires the remote mounted dial to turn off the motor, the dial should be set at 0-10V DC.

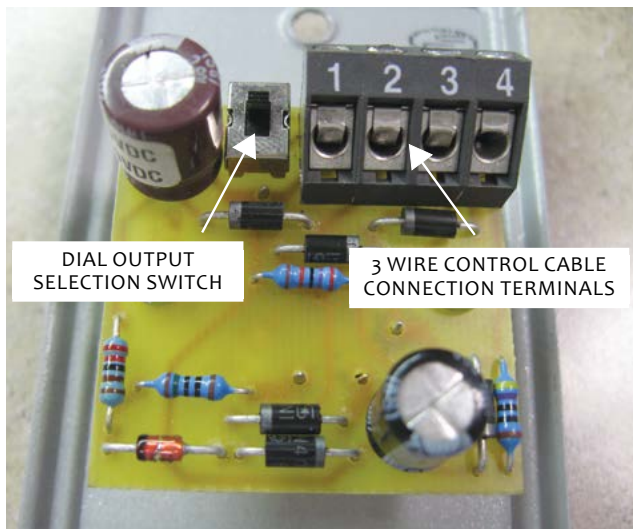

⚠ CAUTION

Always disconnect power before inspection or maintenance. Although motor may be off and not running when a 0-1.9V DC signal is present, high voltage will still be present at the motor.

The field supplied 3 wire control cable connections from the transformer box to the remote mounted dial must be made as shown in table to the right:

The user should verify that the dial is properly working by adjusting the dial and checking that the motor speed changes accordingly. The voltage at the dial should also be verified. 24V AC should be present across terminal 1 and 2. Terminals 1 and 3 should have a DC voltage in the range of 0-10V DC which should vary as the dial is adjusted.

| Connection in Transformer Box | Description | Terminal on Back of Dial |
|-------------------------------|-------------|--------------------------|
| Yellow/White | Common | 1 |
| Blue/Black | 24V AC | 2 |
| Red | 0-10V DC | 3 |

Note that the motor mounted dial acts as a speed reference for this option. In order to have the full speed control range available for a given fan/motor combination, the motor mounted dial must be turned all the way in the CW direction or to the maximum RPM available.

Figure 1 and Figure 2 (page 7) are detailed wiring diagrams for the Remote Mounted Dial option.



Figure 1. Remote Mounted Dial Wiring Diagram — 120VAC Single Phase

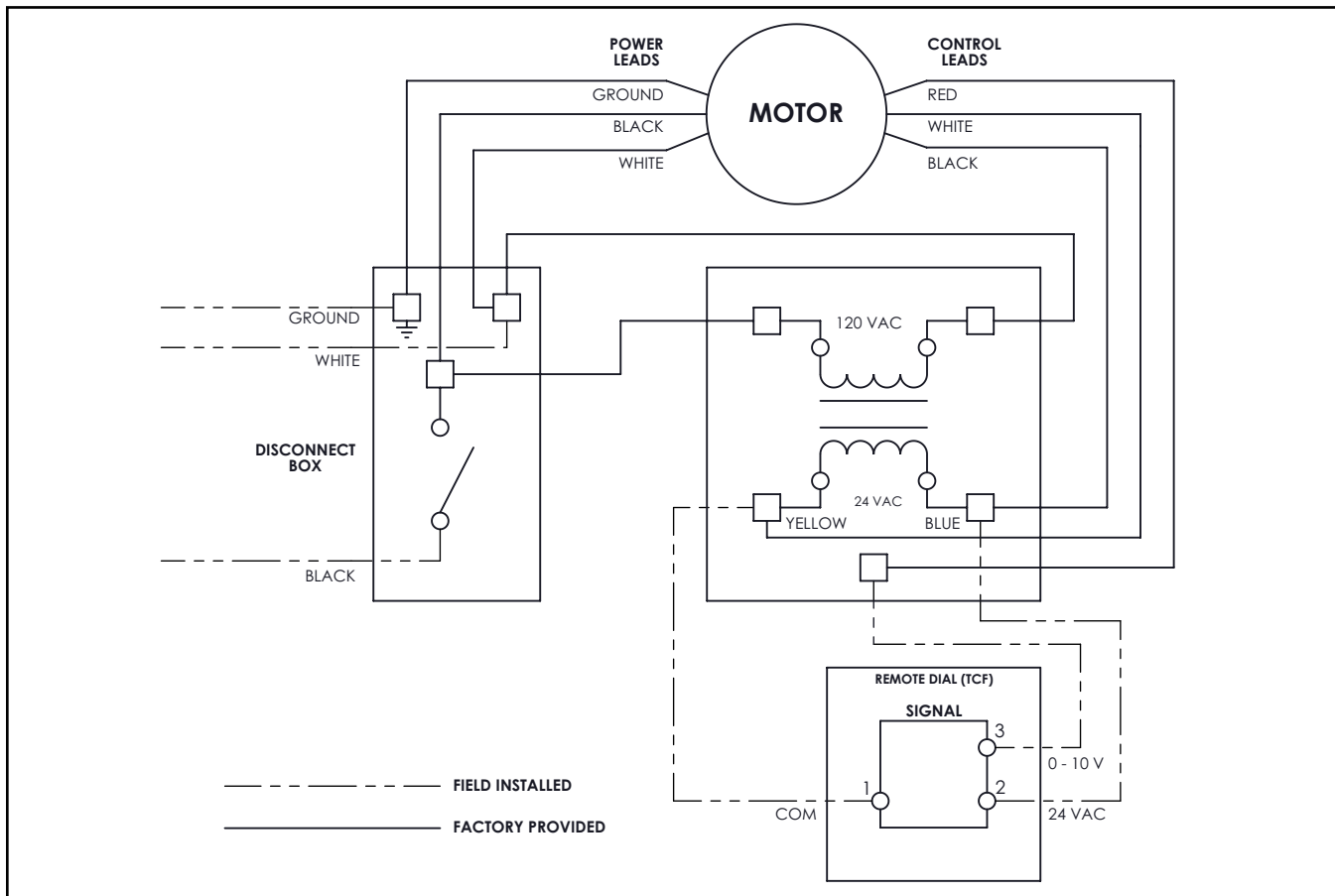
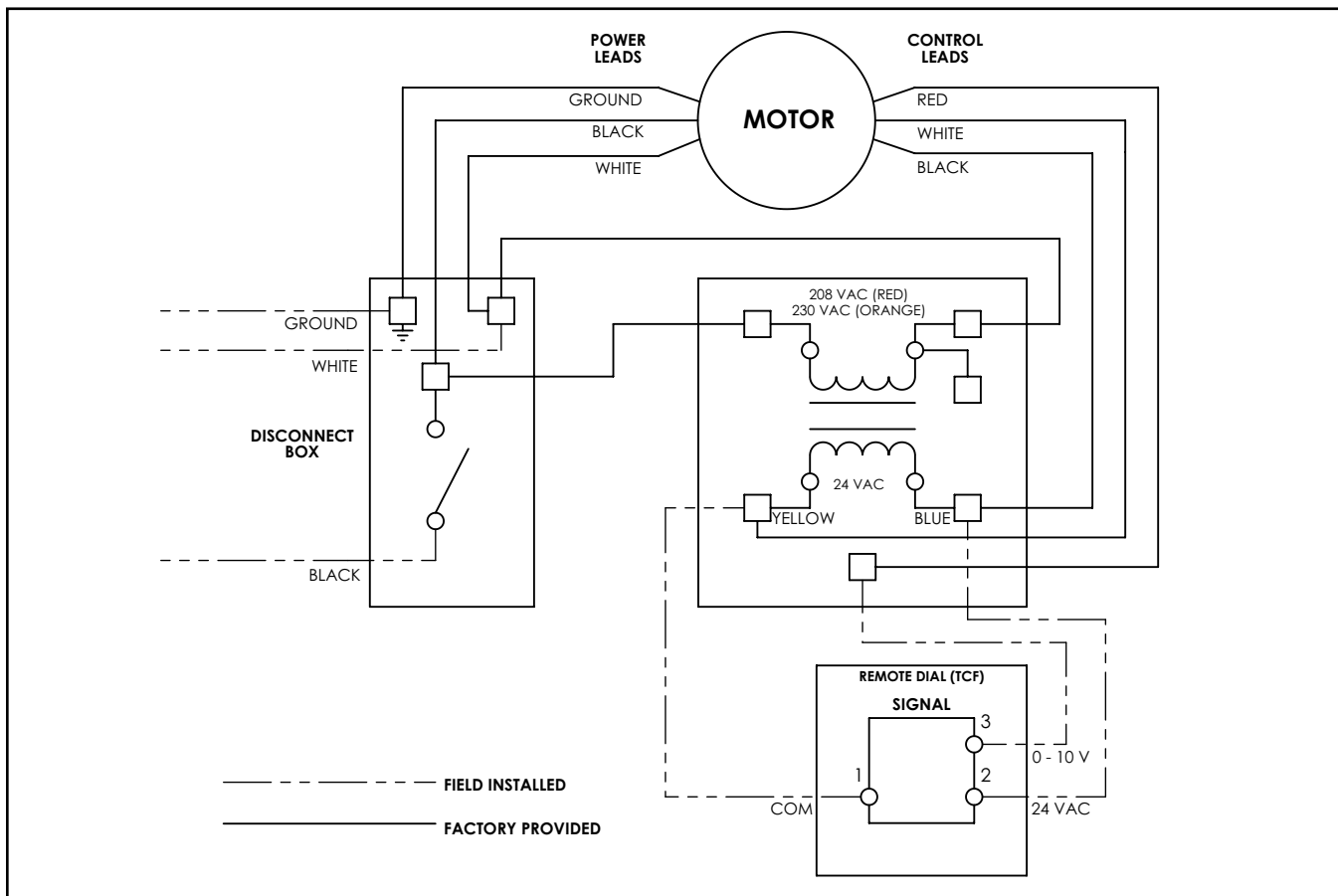

Figure 2. Remote Mounted Dial Wiring Diagram — 230VAC Single Phase



SPEED CONTROL OPTIONS: EC-TEFC MOTORS

This section covers the motors listed in the chart on the right.

| Aerovent Part Number | Manufacturer's Part Number | HP | Voltage/Phase |
|----------------------|----------------------------|----|---------------|
| 67002205 | DV3300A01 | 1 | 115/208-230/1 |
| 67002107 | DV3302A01 | 2 | 208-230/1 |

Installation

1. Connect the motor to AC power and ground the external speed control. Follow Figures 3 and 4 below for appropriate voltage. Use appropriate strain relief (not provided) and branch protection.

⚠ CAUTION

Do not remove conduit box cover for at least five (5) minutes after AC power is disconnected to allow capacitors to discharge. Dangerous voltages are present inside the equipment even when the motor is not rotating. Electrical shock can cause serious or fatal injury.

AC power

Connect it to the motor control as follows:

- a. Connect 115VAC (Black) to L1.
- b. Connect Neutral (White) to N.
- c. Connect Ground to ⚡

Use only Copper Wire for all wiring, minimum 75°C.

⚠ CAUTION

Connection of 115VAC power to "N" will damage the unit.

Figure 3. 115VAC Power Connection to Motor Speed Controller

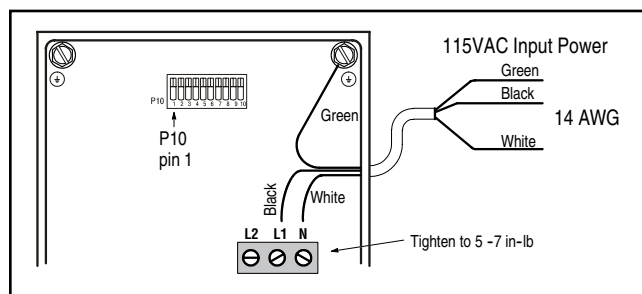

AC power

Connect it to the motor control as follows:

- a. Connect 230V (White) to L1.
- b. Connect 230V (Black) to L2.
- c. Connect Ground to ⚡

Use only Copper Wire for all wiring, minimum 75°C.

⚠ CAUTION

Connection of 230VAC power to "N" will damage the unit.

Figure 4. 230VAC Power Connection to Motor Speed Controller

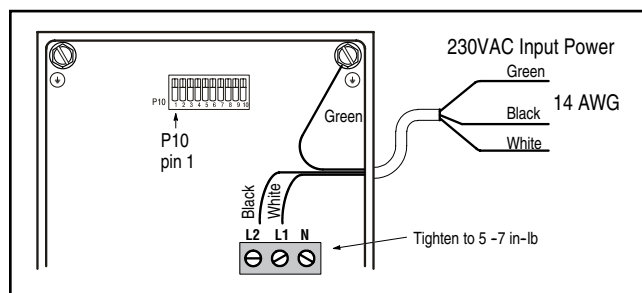

Table 1. Single Phase Power Requirements

| Nominal AC Voltage | Minimum AC Volts | Maximum AC Volts | HP | Input A _{RMS} | Output A _{RMS} |
|--------------------|------------------|------------------|-----|------------------------|-------------------------|
| 115 | 103 | 126 | 1.0 | 12.0 | 2.83 |
| | | | 1.0 | 6.0 | 2.83 |
| 230 | 200 | 264 | 2.0 | 12.0 | 5.29 |

Note: Internally, the Speed Controller provides 240VAC 3 phase at 8kHz switching frequency to the motor.

Table 2. Branch Protection

| Motor Assembly | Fuses | | | | Maximum UL Listed Circuit Breaker |
|----------------|-------------|------------|------------|------------|-----------------------------------|
| | Fast-Acting | | Time-Delay | | |
| | Class | Max Rating | Class | Max Rating | |
| All (1HP-2HP) | RK1 | 20A | RK5 | 20A | 20A |

Note: A different fuse Class may be used as an alternative to the Class shown, provided it is of the same or lesser rating and has equivalent (or better) clearing time and peak let-through characteristics (i.e. Class H, K1, J, T, etc.)

2. Connect the motor to the appropriate speed control option. The motor can accommodate 1 of 2 methods for speed control. The first method is a potentiometer (also known as a remote speed control or motor mounted dial). This is an analog dial which controls the speed of the motor by sending a variable 0-10VDC signal to the motor. CW rotation of the potentiometer increases the speed and CCW rotation decreases the speed (all the way CCW turns the motor off). Note that the motor will run between 2-10V and will shut off from 0-1.9V. See Figure 5 below for details on wiring a potentiometer if required.

Connect the Speed Control Potentiometer to the motor control as follows:

- Connect one end of Potentiometer to P10-1 (12VDC).
- Connect center (wiper) of Potentiometer to P10-2 (Analog Input)
- Connect other end of Potentiometer to P10-3 (DGND)

Use only Copper Wire for all wiring.

The second speed control method is to send the motor a 0-10VDC control signal. From the factory, a 2-wire harness is provided for field connections. Note that the motor does not require a 24V power source to operate in this mode. See Figure 6.

Connect the Control Signal Harness to the motor control as follows:

- Connect a positive voltage source to pin P10-2 (AnalogIn)
- Connect source common to P10-3 (DGND)

Use only Copper Wire for all wiring.

| Description | Wire Color |
|------------------------|------------|
| 0-10VDC (Analog Input) | Red |
| Ground (DGND) | White |

It is the responsibility of the installer/controls engineer to ensure that any field supplied controls are compatible and functional with this motor technology. Aerovent is not responsible for field supplied or customer designed fan or motor controls.

3. Verify rotation of motor is correct by energizing the motor and checking the rotation matches the fan rotation label. This can also be done before any speed controls are wired in by placing a jumper wire between terminals Pin 1 and Pin 2. This will send 10 volts into the motor and cause it to run at full speed. To change the rotation of the motor, swap the T1 (Black) and T2 (Blue) leads (as shown on the right). Note that the motor and fan warranty are void if the motor is rotating in the incorrect direction. Also verify that the motor speed control is functioning properly.

Figure 5. Motor Speed Controlled by a Remote Speed Control Dial (Potentiometer)

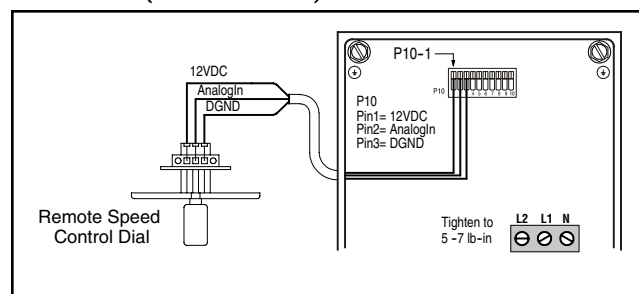
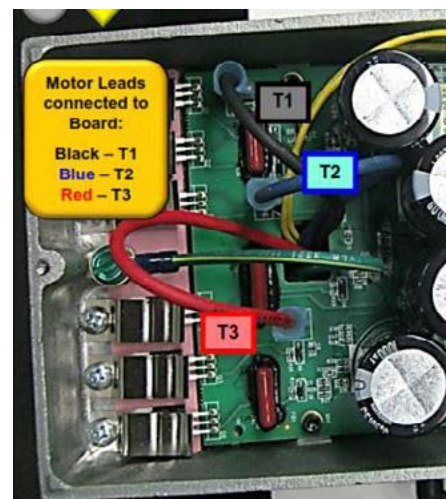
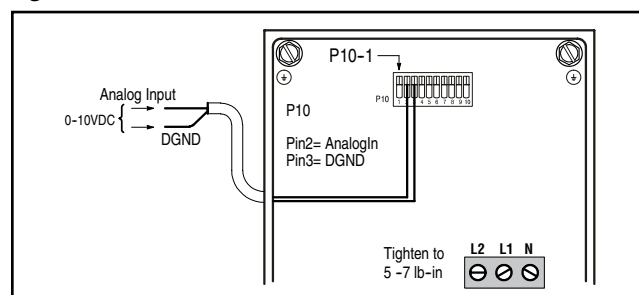

Figure 6. Motor Speed Controlled by 0-10VDC Control Signal



SPEED CONTROL OPTIONS: EC-OP MOTORS

Connections

This motor is designed to be connected to the three-phase supply mains at all times. Motor operation is controlled by an analog DC voltage signal. The motor is shipped with all necessary internal connections made for signal, power and ground connections. The three-phase AC lines are labeled “L1”, “L2” and “L3” and the earth ground line is a green and yellow wire. The customer is required to connect the three-phase AC lines and earth ground to their supply.

Figure 7. Connections for signal and power leads

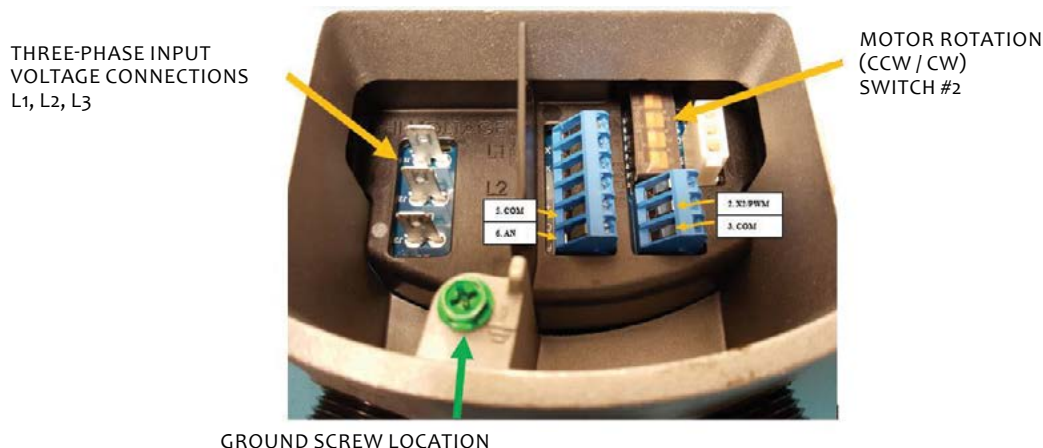

Figure 8. Connection label supplied on cover plate

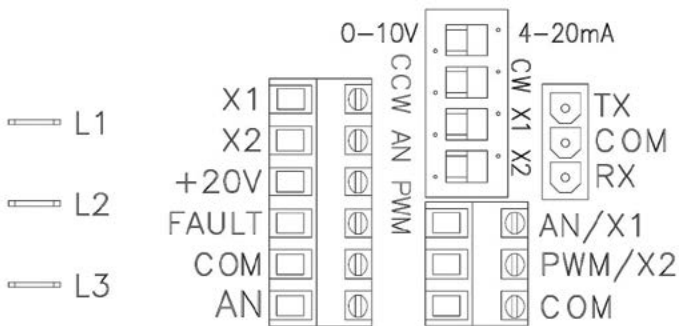

Table 3. Symax motors

| Aerovent Part Number | Manufacturer's Part Number | HP | Voltage/Phase |
|----------------------|----------------------------|----|---------------|
| 67003305 | E56Y22VBH2048 | 1 | 208 - 230/3 |
| 67003306 | E56Y22VBH2049 | 1½ | 208 - 230/3 |
| 67003307 | E56Y22VTH2046 | 2 | 208 - 230/3 |
| 67003309 | E56Y22VTH2047 | 3 | 208 - 230/3 |
| 67003405 | E56Y42VBH2048 | 1 | 460/3 |
| 67003406 | E56Y42VBH2049 | 1½ | 460/3 |
| 67003407 | E56Y42VTH2046 | 2 | 460/3 |
| 67003409 | E56Y42VTH2047 | 3 | 460/3 |

Operation Method

This engineering sample is setup for constant speed operation. The analog DC control voltage controls the target speed to maintain. Speed maximum setting (10V) has been set for 1750 RPM. Speed minimum setting has been set for 200 RPM with a turn on speed of 250RPM at ~1.6V. The torque to speed relationship is dependent on the load on the motor.

Control Method

The default motor control method is 0-10V DC where 0V is off and 10V is full speed. DC signal should be applied per Figure 7. +V DC line attached where shown (AN). DC common line should be attached per Figure 8 where shown (COM).

MAINTENANCE

These motors use brushless technology with sealed bearings so no maintenance is required other than keeping the motors dry and free of dirt, dust and debris. Always keep records of the maintenance that is performed.

TROUBLESHOOTING

Remote Dial does not vary the motor speed (all motor types, except EC-OP)

- Verify that correct connections are made (refer to page 7).
- Make sure that the connections are solid.
- Check control input voltage at connection (inside transformer box).
- Make sure that the dial on the motor is opened CW.

Speed control does not vary the motor speed

- Check voltage to ensure the motor is receiving the correct input voltage.
- Check voltage at the remote dial. 12VAC should be present across the 12V and COM terminals and 0-10VDC should be present between the 0-10V and COM terminals.
- Verify that the potentiometer or 0-10VDC lead is properly wired to the control board according to the diagram.
- Verify that all of the connections inside of the fan and motor are secure.

Motor does not operate (EC-TEFC motors)

- Check that the motor is wired for the correct supply voltage.
- Verify the Status LED is solid red.
- Verify that the jumper wire is present between terminals 9 and 10 on the low voltage terminal board because this is required for the motor to operate.
- Verify that the yellow wires are present on terminals 5 and 6 on the low voltage terminal board.

Fault indication (EC-TEFC motors)

A red LED is located either on the control board or on the side of the conduit box to provide diagnostic assistance of motor faults. When a fault occurs, the LED will blink a specific number of times to identify the fault that has occurred. See the table to the right for fault indications.

When a fault occurs, the LED will blink the number of times corresponding to the fault, pause and then repeat blinking. Count the number of blinks multiple times to ensure that the proper fault has been identified. With most of the faults, the motor will restart automatically. If the motor experiences an overload fault over 10 times within an hour, the motor will shut down to protect itself and the power will need to be reset.

| EC-TEFC Motors | |
|----------------|-----------------------------|
| No. of Blinks | Indicated Fault |
| 2 | Overcurrent |
| 3 | Overvoltage |
| 4 | Undervoltage |
| 5 | Communication Error |
| 6 | Sync Loss |
| 7 | Spin Fault |
| 8 | 3 Sec/60 Sec Motor Overload |
| 9 | Motor Over-Temperature |



WWW.AEROVENT.COM

5959 TRENTON LANE N | MINNEAPOLIS, MN 55442 | PHONE: 763-551-7500 | FAX: 763-551-7501

©2017-2019 AEROVENT