

General Installation, Operation and Maintenance Instructions For Aerovent Products

Throughout this manual, there are a number of HAZARD WARNINGS that must be read and adhered to in order to prevent possible personal injury and/or damage to equipment. Two signal words "WARNING" and "CAUTION" are used to indicate the severity of a hazard and are preceded by the safety alert symbol.

⚠ WARNING
Used when serious injury or death MAY result from misuse or failure to follow specific instructions.

⚠ CAUTION
Used when minor or moderate injury or product / equipment damage MAY result from misuse or failure to follow specific instructions.

NOTICE
Indicates information considered important, but not hazard-related.

It is the responsibility of all personnel involved in installation, operation and maintenance to fully understand the ⚠ Warning and ⚠ Caution procedures by which hazards are to be avoided.

1.0 GENERAL DESCRIPTION

1.1 DEFINITIONS

A vaneaxial fan is an axial fan with a vane section downstream of the rotor. The vane section converts the rotating component of the airflow into axial flow and pressure, increasing the static pressure capability of the rotor.

An adjustable pitch rotor is one where the blade angle can be changed, but only when the rotor is stationary.

A variable pitch rotor, also called controllable pitch, is one where the blade angle can be changed while the fan is running.

1.2 ARRANGEMENTS

Axial fans are available in two different configurations, defined as follows:

Arrangement 4, Type 2 — The rotor is mounted directly on the motor shaft, and the motor is upstream of the rotor, with both rotor and motor enclosed in the fan tube.

Arrangement 4, Type 3 — The rotor is mounted directly on the motor shaft, and the motor is upstream of the rotor, but supported outside the fan tube.

Aerovent axial fans offer the following combinations of these basic definitions, using the nomenclature shown:

Description	AXICO
Vaneaxial Fan	X
Adjustable Pitch	FPDA
Variable Pitch:	
Electric Control	FPMC
Hand Crank Control	FPMC
Pneumatic Control	FPAC
Arrangement 4, Type 2	X
Arrangement 4, Type 3	X

1.3 APPLICATION

If the application requires that the inlet to the fan be ducted, Arrangement 4 Type 3 cannot be used. All the other arrangements are furnished with an inlet duct flange to which an inlet duct or an inlet bell can be fastened.

Arrangement 4 Type 3 fans are ideally suited for plenum applications with a free inlet condition as this arrangement can permit the fan to be placed much closer to the coils or filters upstream.

1.4 ACCESSORIES

- Various accessories are available for AXICO fans.
- a. Inlet bell and screen (standard on Arrangement 4 Type 3 fans)
 - b. Inlet cones
 - c. Vane section (standard on AXICO fans)
 - d. Discharge diffuser sections (two types)
 - e. Acoustic discharge diffuser sections
 - f. Flexible duct connections and band clamps
 - g. Gravity backdraft dampers
 - h. Vibration isolation

1.5 OPTIONS

AXICO fans may be furnished with various options to meet job requirements:

- a. Legs for floor mounting.
- b. Brackets for vertical, horizontal, or angular mounting from the floor or ceiling.
- c. Electric operator or manual hand-wheel for adjustment of AXICO FPMC when in operation, or quadrant and clamp adjustment when the fan is turned off.
- d. AXICO fan operators and positioners located at other than top dead center.

1.6 NAMEPLATE NOMENCLATURE

The model number information on each fan nameplate is explained on page 15.

2.0 INSTALLATION

2.1 RECEIVING/INSPECTION/STORAGE

Each Aerovent fan is shipped on a wooden pallet and is covered with plastic for weather protection.

Carefully inspect the fan upon arrival for damage incurred during shipment. Immediately report any damage to both the factory and the carrier.

For short-term storage prior to installation, the fan should remain covered with plastic wrap on the shipping pallet and stored in a clean, dry location away from the elements. If storage is to be for a period longer than 30 days, see page 16 for long-term storage instructions.

2.2 LIFTING

Aerovent fans should be lifted using slings. Note that on AXICO fans the slings should be placed under the skids, and spreader bars used as required. Under no circumstances should the vane section be used for lifting.

2.3 MOUNTING

Depending on the type of fan support specified, the fan can be floor mounted on legs, supported on a structural frame or ceiling hung if clips or support brackets are included, and again supported on the floor on a frame, or ceiling hung if the fan is for vertical airflow.

2.3.1 Vibration Isolators

The fan is dynamically balanced to reduce vibration to a low level. However, it is recommended that the fan be supported on vibration isolators. Isolators should be selected for each installation in accordance with individual requirements.

The weight distribution between mounts is not equal on Aerovent fans. Consult the factory for isolator selection or mount loads. Isolators should be selected to support the unequal load with equal deflection. A subbase can be used to equally distribute the load to the isolators. Concrete inertia pads are generally not required on Aerovent axial fans. When mounting isolators or tie-down bolts through the base frame of an Arrangement 4 Type 3 fan, it is recommended that you use a beveled washer between the base frame and the nut. See Figure 1.

Figure 1.

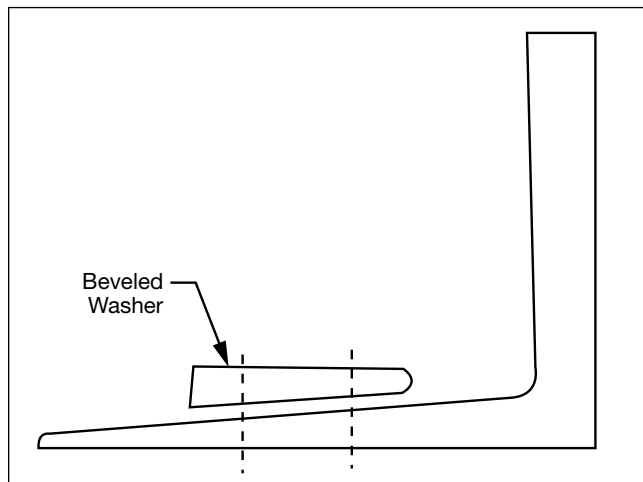

2.3.2 Fan Reactions

It is essential to minimize fan movement due to starting torque and air thrust force. These forces must be resisted to maintain duct alignment and prevent damaging the flexible connectors. Isolators must be selected with adequate stiffness to resist these forces. Snubbers may be required in some installations to limit the fan movement.

2.4 DUCT CONNECTIONS

All fans should be closely aligned with the ductwork. A flexible connection should be provided between the fan and duct to prevent structure-borne noise from being transmitted to the ductwork. Use band clamps and seal with Borden's Arabol, or equal, to insure mechanical security and prevent leakage on all flexible connections.

NOTICE

Provide a 1-inch to 2-inch gap between the fan and duct to allow for fan movement.

2.4.1 Diffuser and Cone Connection

On AXICO fans, the standard discharge is not intended to be directly connected to the fan vane section. Support the diffuser independently of the fan and provide a flexible connection between the fan and the diffuser. On all Aerovent fans, inlet cones can be directly connected and they also become part of the load to be isolated.

2.4.2 Inlet Bell Connection

The inlet bell may be mounted in a plenum wall with a flexible connection between the outer edge of the bell and a hole in the partition. Provide a 2-inch to 3-inch gap to allow for fan movement.

The inlet bell may be installed protruding into the plenum where space is limited. A metal ring should be installed between the inlet bell and the case flange and a flexible connection installed between the ring and the plenum wall.

2.5 ELECTRICAL

All wiring should conform to local electrical codes and the job specification.

2.5.1 Power Connection

The motor leads terminate in the conduit box. The leads are factory connected for the voltage specified for the job. Motor leads for wye-delta and part-winding starts are not connected. Rigid conduit should be run from the motor starter to the fan with a short section of flexible conduit at the conduit box to allow for fan movement.

Wire size and motor overloads should be sized in accordance with the fan nameplate electrical data. The conduit box is located on the outside of the case on all ducted, direct driven fans. If the motor is outside the fan case, connection will be made directly to the motor.

2.5.2 Motor Rotation

Check motor rotation by jogging the motor. The rotation should be clockwise when viewed from the inlet of the fan. Reverse any two motor leads to change rotation.

NOTICE

It is important that correct motor rotation be established on ducted fans as the rotor will not be visible after an inlet duct is installed.

2.5.3 Electrical Data

If the fan is a variable pitch AXICO fan, it is recommended that the fan not be run until the controls are operational. The fan should be started in accordance with Section 2.5.4 and the electrical data measured and compared to motor nameplate ratings.

2.5.4 Final Check Before Putting Fan Into Operation

1. Check for correct supply voltage and motor overloads.
2. Insure that all loose debris is removed from fan, fan room, plenum and/or all ducts.
3. Check that motor bolts are tight and rotor is centered in fan case with adequate blade tip clearance all-around. See Section 6.6 for motor bolt torque data, and Section 6.7 for minimum blade tip clearance.
4. Hand rotate and then bump the fan starter to check rotation.
5. Start the fan and verify that the vibration is acceptable.

If the fan is a variable pitch AXICO, make the following additional checks.

6. Check that the air supply pressure is correct (60 to 100 psig).
7. Set controller at a low set point for minimum pitch (3 psig branch pressure to the positioner) for direct acting.
8. Verify once again that the vibration is acceptable.
9. Increase the set point for maximum pitch and measure motor current. Check that full load current does not exceed motor nameplate data. Also verify that the vibration level at full pitch is acceptable.
10. Verify that blade pitch changes smoothly throughout the full range as the controller set

point is moved. If the AXICO fan has an electric operator, follow the same procedure except of course varying the signal input circuit to the Honeywell electric opener.

3.0 AXICO FAN BLADE ADJUSTMENT

3.1 FPAC FAN

The FPAC fan has a pneumatic diaphragm incorporated in the hub to operate the blade pitch changing mechanism. Air is supplied to the diaphragm through a rotary union connected to a valve positioner mounted in the vane section. The positioner is mechanically connected to the diaphragm by a flexible cable.

3.1.1 Positioner — Function

The function of the positioner is to modulate the air pressure to the diaphragm in response to the control pressure. By means of the mechanical feedback it can sense the blade pitch and thus satisfy the control set point. The positioner will provide linear response to the control pressure.

The positioner is factory set to operate in the direct acting mode. This means that a decreasing control pressure will cause a decrease in blade pitch and less airflow.

3.1.2 General Description of How It Works

The pilot positioner is a single acting, single-stage, force-balance type control device. Mounted on an AXICO fan, and cable-connected to the rotor operating mechanism, it uses an auxiliary air supply and a feedback cam controlled by the cable to position the rotor mechanism in accordance with the 3-15 psig air signal from the controller.

Figure 2 is a schematic diagram of this system. Remember that the feedback spring maintains upward pressure on the positioner arm at all times, and this keeps the cable in tension. Since the positioner is

Figure 2. Schematic of Pilot Positioner and Direct Acting FPAC Fan

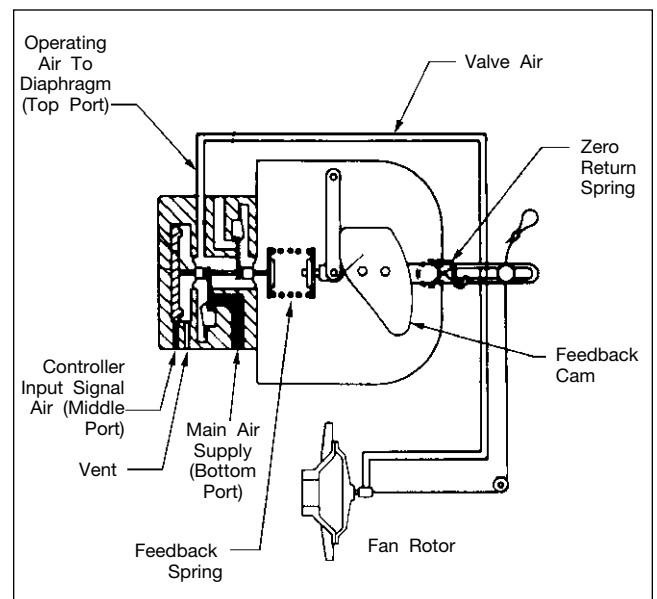

direct acting, a 3 psig instrument gauge pressure results in 0 psig valve gauge pressure or minimum pitch position. When the instrument gauge indicates 15 psig, this results in maximum valve pressure and thus maximum pitch. The tendency of the fan blades is to go to minimum pitch, so that, when the diaphragm pressure is reduced, the spider will move towards the rotor, pulling the positioner arm down and compressing the feedback spring.

3.1.3 Positioner Connections

There are three 1/4" NPT ports on the positioner. The top port is connected to the diaphragm on the fan rotor. The middle port should be field connected to the controller (branch line). The bottom port should be field connected to main air supply. **Supply air should be clean and dry instrument air. Moisture or dirt in the supply air will cause the pilot on the positioner to malfunction after repeated exposure.** The supply pressure to the positioner should be regulated as required to achieve full pitch. The supply pressure needed is a function of fan speed and size.

3.1.4 Positioner Calibration and Adjustment

The positioner is factory calibrated and no further adjustment is normally required. The calibration can be easily checked and corrected if normal fan control cannot be achieved. The positioner must be adjusted if replaced or the cable is removed from the lever arm.

To adjust the positioner, proceed as follows:

1. With fan off, disconnect the air line on the positioner to the fan rotor and connect this line to a 1/4" NPT pressure regulator.
2. Check that the cable is in alignment with the hole where it enters the stator vane core. If not, adjust the positioner on the mounting bracket (not the pin in the slotted arm), keeping the positioner horizontal with respect to the case.
3. Adjust the pressure regulator to supply full line pressure to the fan diaphragm. Loosen the cable clamp on the positioner arm and pull cable tight. Mark the cable where it protrudes through the stator case. This is the maximum pitch position. Reduce the pressure to the diaphragm to zero and start the fan while maintaining tension on the cable by pulling upward on the cable. The fan will now be in the minimum pitch position.

Mark the cable again in the minimum pitch position. Turn off the fan.

 WARNING
<p>Do not release cable tension while fan is in operation. Wait until fan has come to a complete stop.</p>

NOTICE
<p>The blades may not fully return to the minimum pitch position unless fan is operating.</p>

4. Adjust the pressure to the diaphragm to move the cable midway between the two reference marks. Measure carefully and maintain this position. Remove the side cover plate on the positioner.

Grasp the positioner arm and move it to align the line engraved on the cam with the centerline of the cam roller (see Figure 2). Tighten the cable clamp.

NOTICE
<p>The positioner is now mechanically adjusted at mid-range with the fan blade pitch mechanism at the mid position.</p>

5. Reconnect air line from the diaphragm to the positioner.
6. Proceed with the positioner calibration, as described below:
 - a. Connect a 1/4-NPT pressure regulator to the instrument port to simulate a control pressure.
 - b. Turn on the supply air. Adjust the regulator to 9 psig control pressure.
 - c. The mark on the cam should point to the center of the cam follower. If not, turn spring adjusting nut to align the mark.
 - d. Replace the cover plate and reconnect the control pressure line to the middle port.
 - e. The positioner is now adjusted and calibrated to provide linear blade pitch control from a 3 to 15 psig control pressure.

NOTICE
<p>It is advised that a 0-30 psi pressure gauge of known accuracy be used during the calibration procedure.</p>

NOTICE
<p>In the event that a positioner has to be replaced with a new part, the pin in the slotted arm on the new part should be placed in the identical position as on the old one. Specifically, the slot marking should match the distance between the marks made on the cable in item 3 of the adjustment instructions above.</p>

3.1.5 Air Consumption

The bleed rate of the positioner is zero. Under operating conditions, an FPAC fan will use a maximum of 0.25 SCFM of supply air.

3.2 FPMC FAN

The FPMC fan is a mechanical version of the AXICO fan. Pitch control is achieved by a mechanical linkage connected to a thrust bearing in the hub cover. This arrangement is available in three versions:

1. FPMC with electric operator mounted on the outside of the vane section.
2. FPMC with a manual gear/jack mounted inside the core of the vane section, and a handwheel mounted on the side of the vane section to adjust pitch. This version can be adjusted while the fan is running.
3. FPMC with the same linkage as on the motor-operated version, but the input end of the linkage is clamped in one position on a quadrant. This version cannot be adjusted while the fan is running.

3.2.1 FPMC, Electric Motor Operator

The 120 VAC operator is used with FPMC fans. This operator provides position proportion control of the AXICO mechanical blade linkage. The operators are furnished with end limit switches which have been factory set to match minimum and maximum pitch conditions required for each fan. The motor will rotate the output shaft through an arc of 150°, but the switches have been set to give the necessary linkage stroke within this 150° arc. Operating time is 60 seconds for the full 150°, so on an AXICO fan the time will be somewhat shorter. The motor has a 135 ohm balancing slide wire which must also be connected to the control relay. The motor is also equipped with a 135 ohm feedback slide wire to permit an output signal which can be used as the input signal to a second relay which would control a parallel fan.

3.2.1.1 Control

Since fan pitch is being used to control duct system static pressure in the majority of cases, a pressure sensing transducer or slide wire bridge must be used in conjunction with a balancing relay. This relay will operate a single pole double throw switch to feed power of the correct polarity to the operator motor to achieve CW or CCW rotation of the output shaft. If the balancing slide wire is not connected, the motor would run until the limit switch cuts power to the motor in that circuit direction. Not until polarity is reversed would the motor operate, and then it would go through full stroke in the opposite direction until the second limit switch is opened.

By connecting the balancing slide wire circuit back to the balancing relay, the relay is now able to compare the requirements of the duct sensor with the actual rotation of the operator, and the comparison will make or break the SPDT switch, changing operator rotational direction in a stepping manner. Thus, the system becomes proportional.

3.2.1.2 Actuator Electrical Connection

All electric connections should be in strict accordance with the job specification and local electric codes. Refer to the current manufacturer's owner's manual for a schematic wiring diagram.

3.2.1.3 Actuator Replacement

The actuator is factory adjusted to provide the full range of blade pitch movement. Should the actuator be replaced, the limit switches must be adjusted to prevent the motor from stalling at the maximum and minimum pitch positions.

To replace the actuator proceed as follows:

1. Remove the crankarm from the motor shaft without disturbing the ball joint and pushrod location.
2. Remove wiring and mark terminal locations.
3. Remove four mounting bolts and replace actuator with new unit.
4. Remove four screws from the end cover and remove the cover.
5. Connect 120 VAC power to the proper terminals, according to the owner's manual, to drive motor

to mid-position of shaft rotation as indicated by wiper arm location.

6. Move pitch control lever to mid-position and install crankarm on motor shaft.
7. Drive motor counterclockwise, according to the owner's manual, to the maximum pitch position.
8. Adjust limit switch (LS1), according to the owner's manual, to open at this position.
9. Drive motor clockwise, according to the owner's manual, to the minimum pitch position.
10. Adjust limit switch (LS2), according to the owner's manual, to open at this position.



CAUTION

Check that the limit switches are properly adjusted and that the actuator motor does not stall at either of the two extreme positions.

11. Reconnect wiring, according to the owner's manual, and replace covers.

3.2.1.4 Actuator Linkage Adjustment

Should the linkage be removed during fan disassembly, it may be adjusted as follows:

1. Position the pitch control lever and actuator motor at mid-position per Section 3.2.1.3.
2. Install crankarm in an upward vertical position on motor shaft.
3. Install ball joint on crank arm at the minimum radius from shaft, which will permit the wiper arm to operate within the length of the slide wire. It must not run off at either end.
4. Install push rod and tighten ball joint.
5. Adjust limit switches per Section 3.2.1.3.

3.2.1.5 Actuator Pitch Adjustment

The maximum and minimum blade pitch is mechanically set in the rotor. The limit switches in the actuator can be reset to reduce the range between these limits to provide different maximum and minimum airflows. This may be done as follows:

1. Remove terminal box and/or end covers from actuator as required.
2. Energize terminals, according to the owner's manual, with 120 VAC to drive the blades to minimum pitch.
3. Start the fan and energize the proper terminals, according to the owner's manual, to increase the pitch until the desired maximum airflow is obtained.
4. Adjust limit switch (LS1), according to the owner's manual, to open at this position. This will stop the motor at the new maximum pitch position.
5. Energize terminals, according to the owner's manual, to decrease the pitch until the desired minimum airflow is obtained.
6. Adjust limit switch (LS2), according to the owner's manual, to open at this position. The motor will stop at the new minimum pitch position.
7. Check limit switch adjustment by driving motor through range.
8. Replace terminal box and/or end covers as required.

3.2.2 FPMC Fan, Handwheel Version

An external handwheel on the vane section is connected to a miniature wormgear jack inside the core of the vane section. This in turn is connected to the hub cover of the rotor. If the handwheel is installed on the right side of the fan, looking in the direction of airflow, counterclockwise rotation of the wheel will increase blade pitch. If installed on the left side, clockwise rotation will increase pitch. With this arrangement the blade pitch can be changed while the fan is running.

3.2.3 FPMC Fan, Quadrant

With this version of the FPMC, the external linkage to the rotor is clamped in one position by a handwheel on a fixed bolt. The blade forces are such that the fan must be turned off to adjust the blade pitch. Move the lever upstream to decrease pitch, downstream to increase it.

3.3 AXICO FPDA FAN

The FPDA fan is an adjustable pitch fan. The blade pitch has been factory set to meet the airflow requirement of the job specification. The blade pitch may be changed to meet other airflow requirements. The hub fairing is marked with degree marks at the leading edge of the fan blade. The first mark near the inlet side of the fairing is 60°. The last mark near the center of the fairing is 25°. The intermediate marks are in 5° increments. The marks are referenced to the center of the leading edge of the fan blade.

3.3.1 Blade Pitch Adjustment

To set the blade pitch proceed as follows:

NOTICE

An 8 mm key with a square drive adaptor fitted to a torque wrench is required.

1. Remove the stator section access panel per steps 1 through 5 of Section 5.7 to gain access to the fan blades on Arrangement 4 Type 2 fans. Access on other fans may be gained by removal of the protective inlet screen if desired.
2. Loosen the four M12 blade bolts until the blade is free to rotate.
3. Rotate the blade to align the center of the leading edge with the desired pitch mark.



CAUTION

Do not exceed 55° blade pitch without consulting factory.

4. Alternately tighten opposite blade bolts to 40 ft-lb.



CAUTION

It is important that the bolts are torqued to the specified value. Do not hand-tighten the bolts.

5. Repeat Steps 2 through 4 for all blades.
6. Replace stator section access panel or inlet screen.



CAUTION

The motor current should be checked not to exceed the nameplate rating when blade pitch has been increased.

4.0 INSTRUMENTATION (PITCH CONTROL) AXICO FANS

4.1 GENERAL

Various parameters such as pressure, temperature, gas concentration, relative humidity, or velocity can be measured to provide the required system airflow. The sensor is connected to a controller which provides an electrical or pneumatic control signal to the fan. The fan pitch is modulated to meet the system airflow set point requirement.

4.2 FPAC FAN

The FPAC AXICO fan is factory adjusted to go from minimum to maximum pitch with a 3 to 15 psig pneumatic control signal. Two-position or multi-position pitch settings may be obtained with intermediate control pressures. The blade pitch may also be manually controlled by supplying the control pressure from a pressure regulator.

4.3 FPMC FAN

The FPMC fan actuator is adjusted at the factory to go from minimum and maximum pitch with limit switches at the ends of the stroke. The limit switch settings may be changed to reduce the range of blade pitch for two-position step control from contact closure. See Figure 3 for typical wiring diagram.

4.4 PARALLEL FAN OPERATION

When two or more fans are installed to operate in parallel, two problems are commonly experienced.

1. When less than all the fans are in operation, air circulates backwards through the fan that is shut down, causing it to freewheel backwards. This can be very damaging to the motor when the fan is restarted.
2. When all fans are running together, they may not be completely stable.

SOLUTION: The signal to all fans must be a common signal, and it should be a heavily damped signal so the changes of blade angle occur very slowly. Also the fans must have their positioners calibrated so that all positioner arms are at the same angle for a given control pressure. A second check can be made to insure that motor amps match within 5% at a given signal pressure.

NOTICE

STARTING A FAN WHILE THE ROTOR ASSEMBLY IS WINDMILLING BACKWARDS VOIDS ALL MOTOR AND FAN WARRANTIES.

5.0 MAINTENANCE

5.1 GENERAL

Aerovent fans are a quality product designed and manufactured for minimum maintenance and long operating life. They should provide years of trouble-free service if the following maintenance procedures are followed.

Aerovent fans are balanced at the factory to the following standards. NEMA has set standards for motor balance which are also shown. Bearing life and lubrication requirements are based on the NEMA standard. The more stringent Aerovent standards allow for normal build-up of dirt on rotors; use, evaporation and/or shifting of lubricants; and normal wear. If a fan appears to be out of balance, it is wise to clean and grease before attempting to balance as this may resolve the situation in the simplest manner.

In the event that the fan does not require dynamic balancing, balancing weights should be added as described in this text.

Balance weights should be located only between the blade hole openings and on the front and rear of the hub fairing. See Figure 4.

Balance weights should not exceed the weight (in grams) listed in Figure 4.

RPM	AEROVENT STANDARD	SHUT-DOWN	MILS ALARM
3600	0.6 Mils Peak/Peak	2.20	1.42
1800	0.8 Mils Peak/Peak	4.40	2.84
1200	1.2 Mils Peak/Peak	6.70	4.26
900	1.6 Mils Peak/Peak	8.90	5.60

5.2 MOTOR LUBRICATION

Motor bearings do not require initial lubrication unless the fan has been in storage over six months. If this is the case, the motor should be lubricated initially. Refer to motor IOM.

Lubricate motor bearings with grease gun at the following intervals and numbers of strokes:

HORSEPOWER	PERIOD	STROKES (SEE NOTE)
5 to 7½	12 Month	1
10 to 40	6 to 12 Month	3
50 to 150	6 Month	3

NOTICE

Normal amount of grease delivered by a hand cartridge type grease gun.

Use one of the following or equal lubricants if the motor IOM calls for Polyurea base greases.

Chevron SR-2 IKO A.F. No.2
Polyrex EM

The grease fittings must be clean to prevent contamination. The fittings are located as follows:

5.3 AXICO FAN LUBRICATION

TYPE FAN	LOCATION
Arrangement 4, Type 2	Fan case adjacent to conduit box
Arrangement 4, Type 3	End of motor base



CAUTION

Do not over lubricate bearings or use a grease other than specified.

5.3.1 Rotor

Rotor lubrication is described in Section 5.6 under Routine Maintenance.

5.3.2 AXICO FPMC Lubrication

In addition to the above in Section 5.3.1, all FPMC rotors have a thrust bearing in the hub cover. The grease lead to this bearing is on the outside of the vane section. Grease as per Section 5.2 should be applied, one stroke once a month of fan usage.

The FPMC unit with handwheel adjustment has a grease fitting on the jack inside the vane section in addition to the thrust bearing. Unless the pitch is changed frequently, there is no reason to lubricate this more often than as part of the two-year maintenance procedure.

The FPMC unit with external electric operator requires lubrication with SAE 30 motor oil at the pivot joints on the linkage every six months. The actuator requires no lubrication.

5.4 AIR LEAKS ON AXICO FPAC FANS

If, during the monthly check, an AXICO FPAC fan is found to be acting erratically, and if the problem is not in the external control (indicated by a constant varying 3 to 15 psig input signal), then check for air leaks.

Listen with your ear close to the positioner. If there is an erratic sound of air escaping when the fan is at maximum pitch, replace the pilot on the positioner (part number F10046301).

If the pressure to the diaphragm will not hold at the same level as main air pressure when the control pressure is 15 psig, inspect for an air leak between the positioner and the rotor. Shut the fan off, but maintain pressure to the diaphragm, and proceed as in Section 5.7 to remove the access door to the vane section. Check the air line, the diaphragm cover bolts, and the rotary union for leaks (turn fan by hand to detect rotary union leaks).

If the rotary union is removed or replaced with a new one, use Loctite Stainless Steel PST on the threads going into the diaphragm cover.

5.5 SIX-MONTH INSPECTION AND MAINTENANCE

The motor bearings may require lubrication depending on motor size per Section 5.2.

The FPMC fan linkage should be lubricated per Section 5.3.2.

5.6 ANNUAL AND TWO-YEAR MAINTENANCE

A minor inspection of the AXICO rotor is required every two years, but recommended each year for continuous duty fans or fans operating with dirty or contaminated air. Remove the access panel of the vane section as described in Section 5.7 and inspect the blade links to be sure the spherical bearings are

Figure 4.

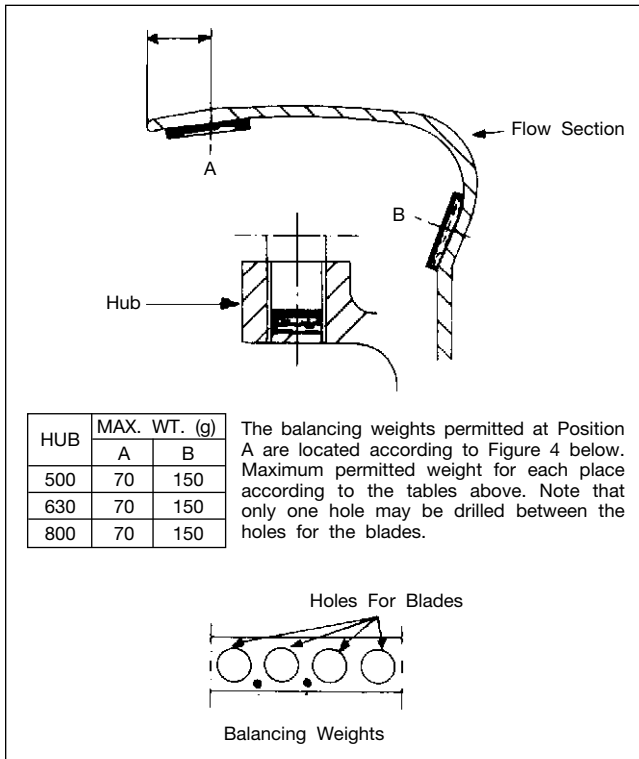

not binding, and apply an aerosol lubricant such as CRC or WD-40.

Grease blade shaft bearings by applying grease through the fitting in the bearing housing until excess grease comes past the seal. Wipe away excess.

NOTICE

If the spider is the old style that uses grease, apply 4 to 5 strokes of a grease gun to the grease fitting behind the spider. This will lubricate the spider hub sliding joint. Before closing up the access panel, operate the control to cycle the pitch several times to insure all parts move smoothly.

Every two years it is recommended that you replace the rotary union with a new one. The longevity of the union is dependent on the quality of the compressed air supply, and it is a simple precaution to replace it while it is accessible.



CAUTION

Use Loctite 242 on the two screws holding the flexible cable bar to the rotary union at any time these screws are removed and replaced.

This operation should take no more than 1 to 2 hours per fan.

5.7 VANE SECTION ACCESS

Both the FPAC and FPMC fans have removable access sections in the vane section. This provides enough visibility and working space for all maintenance short of removing the fan rotor from the motor shaft.

To remove the access sections, proceed as follows:

1. Remove the flexible duct connection between the vane section and the diffuser or duct.
2. Remove the 1/4" bolts at the side of the vane section and remove the 1/2" washers and bolts at the flange of the access panel.
3. Remove the panel exposing the internal stator vanes.
4. Remove the 1/4" bolts from the side of the inner case.
5. Remove the inner core access panel with the three vanes welded to it. The interior of the vane section and the operating mechanism of the rotor is now accessible.

6.0 ROTOR REPAIR & REMOVAL (Not Required For Maintenance)

6.1 ACCESS TO ROTOR

FPAC Fan

1. Remove the access section as described in Section 5.7.
2. Remove the air line from the rotary union.
3. Remove the two screws holding the flexible cable bar to the rotary union.
4. Remove the 1/2" nuts and washers around the vane section flange while supporting the vane section.
5. Slide the vane section off the fan case and remove it sideways. The rotor is now removable.

This operation should take no more than 1 to 2 hours per fan.

FPMC Fans

1. Remove the clevis pin in the vane section core.
2. Remove the drive linkage to the operator, if used.
3. Remove the clevis pin between the bar linkage and the fixed bracket on the fan. The bar can remain in the vane section.
4. Proceed with steps 4 and 5 as described above for FPAC vane section removal.

6.2 ROTOR REMOVAL

(Not Required For Maintenance)

If the rotor is to be removed from the motor shaft, proceed as follows:

FPAC Rotor

Refer to Figure 6 for item identification.

1. Measure and record the distance from the end of the stud (10) to the stud bar (26).



CAUTION

This distance must be maintained at assembly to set the maximum pitch.

2. Remove the nuts (21), stud bar, and springs (11) from the studs.
3. Remove the bolts (15), diaphragm cover (1) and diaphragm (8) from the spider (2).

 **CAUTION**

Mark the position of the diaphragm cover with respect to the spider so that it can be installed correctly and rotor balance be maintained.

- The motor shaft bolt (32) is now visible. After removing it, the rotor can be pulled off the motor shaft. Two threaded holes are provided in the face of the hub to anchor a puller bar.

FPMC Rotor

Refer to page 14 for item identification.

- Measure and record the distance from the end of the stud (10) to the first locknut (21).

 **CAUTION**

This distance must be maintained at assembly to set the maximum pitch.

- Remove the nuts (21) from the studs.
- Remove the bolts (15) around the hub cover (59) and take the cover off.

 **CAUTION**

Mark the position of the diaphragm cover with respect to the spider so that it can be installed correctly and rotor balance be maintained.

- The motor shaft bolt (62) is now visible. After removing it, the rotor can be pulled off the motor shaft. Two threaded holes are provided in the face of the hub to anchor a puller bar.

**6.3 ROTOR DISASSEMBLY & INSPECTION
(Not Required For Maintenance)**

If the rotor is to be serviced on site, proceed as follows.

- Remove the diaphragm cover and diaphragm (FPAC) or hub cover (FPMC) as per Section 6.2.
- Remove the bolts retaining the links to the spider arms. Mark the spider arms and blade bearing housings to insure proper reassembly.
- Slide the spider off the hub, using a continuous twisting motion.
- Remove the four socket head screws from each blade, using an 8 mm hex key. Remove the blades from the bearing housings. Remove the spring, plunger, air seal, and grease gasket from each blade position.

 **CAUTION**

Mark all parts to insure they will be reinstalled in the exact location from which they were removed. Also, all parts must be thoroughly cleaned, and kept clean until everything is reassembled.

- Remove the blade shafts, blade bearing, and bearing housing from the hub. The blade shafts have been assembled, using Loctite 242 thread sealant, so it may be necessary to apply heat to break loose the thread; do not exceed 250°F.
- Clean the blade bearings with solvent or kerosene.

 **CAUTION**

Do not mix races and rollers as the bearings should be maintained as a set.

After the bearings are clean, inspect the contact surfaces for signs of spalling, pitting, cracks, brinelling, or smearing. Replace all bearings from spare parts if there is evidence of wear. If the bearings are not to be immediately used, coat with oil and wrap in grease paper.

- Clean the threads on the shafts with a wire brush to remove the sealant.
- Clean all remaining parts with solvent to remove dirt and grease.
- Inspect the spider bore and hub bearing surfaces for galling. Lightly dress out any surface defects with fine emery paper and clean with solvent.

DO NOT remove the hub fairing (6) from the hub as it will affect the rotor balance.

- FPMC Thrust Bearing
 - Remove the three bolts holding the grease re-tainer plate inside the hub cover. Remove the bearing nut and lock washer from the shaft. Then withdraw the shaft and attached clevis from the bearing.
 - Check the thrust bearing for wear. If loose or noisy, press out the bearing and replace with a new part from spares. Apply Loctite 271 between bearing O.D. and cover.

6.4 ROTOR ASSEMBLY

To assemble the rotor proceed as follows:

NOTICE

An 8 mm hex key with a square drive adaptor fitted to a torque wrench is required.

- Grease the blade bearings with Chevron SRI-2 or equal and assemble on shaft with bearing retainer.

NOTICE

It is important to maintain clean conditions when lubricating bearings.

All parts requiring Loctite must be clean and free of oil and dirt or Loctite will not cure completely. To clean, use a non-lubricating cleaner such as trichloroethane.

- Apply Loctite grade T. Primer to blade shaft threads and hub threads. Allow to air dry 5 minutes. Apply Loctite 242 to the threads of the shaft. Screw into the hub until the bolt bottoms firmly on the shoulder. Torque to 60 ft-lbs.

3. Assemble blade, spring, plunger, plastic washer (24) and new grease gasket (30) to bearing retainer. The proper orientation is as follows when looking at the open end of the rotor.
 - a. Position blade into fairing with the concave surface facing the mechanic and the longer trailing edge of the blade to the right.
 - b. Position bearing retainer with counterbalance lug facing the mechanic and link lug to the right at about a 45-degree angle to the blade.
 - c. The washer fits between blade and bearing retainer inside the fairing.
 - d. The spring, plunger, and gasket fit between the blade and shaft. Tighten the three 12M x 70 bolts to 70 ft-lbs with the 8 mm hex key and torque wrench and the 12M x 35 bolts to 60 ft-lbs.
4. Clean the spider, teflon insert, and hub with a solvent to remove any dirt and grease. Carefully inspect the hub and spider bearing surfaces for signs of galling. Lightly dress out any surface defects with fine emery cloth and thoroughly clean with solvent. Inspect the teflon insert for excessive wear. Replace insert if needed. Apply Chevron Black Pearl grease, or equal, to the sliding cylindrical surfaces.

NOTICE

If your spider does not have the teflon insert, fill the annular cavity in the spider bore with grease.

5. Replace the spider on the hub using the same twisting motion to prevent jamming. Check that the spider slides freely on the hub. If not, repeat Step 4. Position the spider as marked in Step 2 of Section 6.3.
6. If the link bearings show any perceptible play or are frozen, replace all the links with new parts from spares. Use a torque wrench to tighten the bolts to 25 ft-lbs. Check that the mechanism operates freely as the spider is moved in and out. See note on page 12.
7. **FPMC Only** (Refer to Section 6.5)
 - a. Replace the diaphragm with a new part from spares. Using a torque wrench, progressively tighten opposite bolts to 25 ft-lbs.

NOTICE

The crown in the diaphragm fits inside the diaphragm cover.

- b. Replace the rotary union (33) with a new part from spares. Clean and prime the threads with Loctite grade T primer, allow to air dry five minutes, and apply Loctite stain less steel PST. Tighten until firmly seated on shoulder.
- c. Replace the springs, stud bar, and nuts on the studs maintaining the position recorded in Step 1 of Section 6.2. Tighten the jamb nuts to 24 ft-lbs.

8. **FPMC Only** (Refer to Section 6.5)
 - a. Replace the thrust bearing if it has been removed after packing it with Chevron SRI-2. Replace the bearing shaft, lock washer, and bearing nut, and pack the cavity with grease. Replace the spacer, grease retainer plate, and the three bolts.
 - b. Replace the hub cover in the position marked in Step 3 of Section 6.3. Tighten the bolts to 25 ft-lbs.
 - c. Replace the nuts on the studs, maintaining the position recorded when they were removed. Tighten each jamb nut to 24 ft-lbs.

6.5 ROTOR INSTALLATION

If the rotor has been removed from the shaft, obviously it must be put back in place prior to attaching the diaphragm cover to hub cover as described above. To install the rotor on the shaft, proceed as follows:

1. Clean fan shaft with solvent and apply a film of grease. Locate key in keyway.
2. Slide rotor on fan shaft.

NOTICE

It may be necessary to use a bar and a ½"-13 UNC stud threaded into the motor shaft with a nut to pull the rotor on the shaft.

3. Clean bolt and shaft threads and prime with Loctite grade T primer. Blow out internal threads with air and allow to air dry 5 minutes. Apply Loctite 242 to threads.
4. Install washer and bolt and torque to 50 ft-lbs for ½" bolt; 15 ft-lbs for ¾" bolt.
5. Proceed with remainder of assembly depending on fan type per Section 6.4.

6.6 MOTOR BOLT TORQUE

Motor bolts should be torqued to the following specifications. Remember that it is not possible to check a torqued bolt unless it is loosened first, as torque must be applied evenly until the desired torque is reached. To tighten further after a given torque value has been reached requires much more torque to get the nut started than will be required to keep tightening it, so the desired final torque must be reached in one movement. All bolts are grade 5.

BOLT SIZE	TORQUE (FT-LBS)
5/16-18	13
3/16-16	27.5
1/2-13	75
5/8-11	150
3/4-10	240
7/8-9	380

6.7 MINIMUM BLADE TIP CLEARANCE

The following dimension is the minimum clearance between the tip of any blade and the fan case.

FAN SIZE	MIN. TIP CLEARANCE (IN.)
071	.030
080	.030
090	.034
100	.038
112	.043
125	.049
140	.055
160	.063
180	.072
200	.080

6.8 SETTING MAXIMUM PITCH ON FPAC & FPMC FANS

If it should become necessary to adjust the maximum blade pitch on these fans, proceed as follows:

- Remove vane access section as per Section 5.7.
- Release the two lock nuts on each stud (10) to allow a change in their position.
 - Set a protractor at the desired blade angle, 45°-47°, etc.
 - Bring fan to maximum pitch. Have the nuts on the studs at same distance to start (item 21, near hub on Figure 6 in the AXICO instruction manual).
 - Check angle by placing the blade of the protractor (scale) across the root (base) of the blade. When the proper angle is found, the base of the protractor should be parallel to the edge of the fairing. See Figure 5.
 - Adjust by turning stop nut (#21). Be sure that both springs are compressed solid at the same time or the spider will hang up on the hub.

NOTICE

The fairing is scribed with a line that represents the maximum blade angle that was set at the factory. This mark can be used as a reference to check the angle. Factory blade angle is indicated on nameplate.



CAUTION

Do not set maximum pitch stops at a blade angle higher than 55°.

- Tighten each locking nut.
- Reassemble the vane access section.

6.9 MINIMUM PITCH SETTING

Aerovent AXICO fans may have minimum pitch setting accomplished by use of two extended bolts in the diaphragm cover. This may be used to prevent the flow of any system from going below a certain specified minimum.

Size 125 and larger have minimum pitch stops as standard set, if not otherwise specified, to 0 flow. Consult factory for specific details on specific fans.

Figure 5.

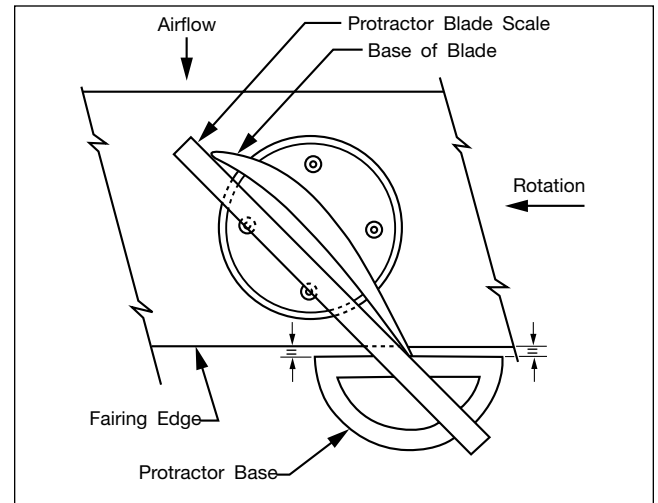

7.0 RECOMMENDED SPARE PARTS

7.1 GENERAL

Spare parts may be ordered either from your Aerovent representative or directly from the factory. Prices will be quoted at time of order. Delivery can generally be made from stock. To order spare parts, specify:

- Fan model number
- Fan serial number
- Part description
- Part number
- Quantity required

The fan model and serial number is on the fan nameplate.

7.2 FPAC SPARE PARTS

It is recommended that the following spare parts be stocked to service FPAC fans:

Part Description	Part No.	Qty. Req'd
Positioner (Pilot Ass'y)	F10046301	1
Rotary Union	F10016701	1
Cable Assembly	F20034902	1

7.3 FPMC SPARE PARTS

It is recommended that the following spare parts be stocked to service FPMC fans:

Part Description	Part No.	Qty. Req'd
Electric Actuator Input Signal:		
4-20MA	F10103502	1
120 VAC	F100165	1

7.4 TOOLS AND MATERIALS

Special tools and materials are available from the factory to facilitate maintenance and repair of Aerovent fans. These may be ordered by part description, part number, and quantity required.

Part Description	Part No.	Qty. Req'd
Loctite Grade T Primer	F10024401	6 oz. aerosol
Loctite 242	F10024402	100cc bottle
Loctite Stainless Steel PST	F10024406	8.46 oz. tube
Gray Touch-up Paint	P4332028	16 oz. aerosol
Tool, 8 mm hex x 3/8 square adaptor for AXICO blade shaft	F10024701	1

FPAC-FPMC ROTOR PARTS

*Same Part for FPAC-FPMC

Part	Size 050 Hub	Size 063 Hub	Size 080 Hub
1. DIAPHRAGM COVER (FPAC ONLY)	F300606	F300606	F301121
2. SPIDER W/TEFLON INSERT	F301457	F301458	F301120
*5. HUB	F400811	F400811	F400806
*6. HUB FAIRING	F300609	F300603	F401335
*7. SHAFT, BLADE	F20132901	F20132902	F20132901
8. DIAPHRAGM, FPAC	F200354	F200354	F200387
3. BLADE BEARING HOUSING FPAC & FPMC F30147701			
*4. BLADE			
SANDCAST	F100461 (FAN MODELS 160, 180 & 200 ONLY)		
DIE CAST	F101062 (FAN MODELS 080 THRU 140 ONLY)		
9. PLUNGER	F200355	28. NUT	F10022210
10. STUD — 050/063	F20035601	30. GASKET	F200802
080	F20035605	31. GREASE FITTING	F10052303
11. SPRING, FPAC	F10049802	32. ROTOR BOLT	F100334
12. LINK, SILVER	F200357	33. ROTARY UNION	F10016701
LINK, GOLD	F200949	34. WASHER, HUB	
13. SOC HD C'SK SCR	F10022201	050/063	F20038501
14. HEX HD SCR	F10022203	080	F20038502
15. HEX HD SCR	F10022240	35. SNAP RING	F100321
16. HEX HD SCR	F10022239	36. THRUST WASHER	F200393
17. HEX HD SCR	F10022240	76. GREASE SEAL	F100812
19. LOCK WASHER	F10022213	77. WIRE RING	F100813
20. HEX NUT	F10022209	78. O-RING	F10089801
21. HEX NUT	F10022210	79. CABLE ASSEMBLY	F20034902
22. BEARING, BLADE	F100201	80. PAN HEAD SCREW	F10054301
23. SPRING, BLADE	F10020001	81. HOSE CLAMP	F10051901
24. AIR SEAL	F200350	82. TEFLON SLEEVE	
26. PLATE — 050/063	F300630	050/063	F201463
080	F201018	080	F201486
27. SOC HD C'SK SCR	F10022216	83. OILITE BUSHING	F101058

NOTES: 1. IF BOLTS #16 AND/OR #17 ON LINK MOUNT ONLY ARE REMOVED, REPLACE WITH NEW BOLTS.

DO NOT REUSE THESE ITEMS:

BOLT #16 — PART NO. F10022239

BOLT #17 — PART NO. F10022240

2. GOLD BLADE LINK IS TO BE USED ON ALL FANS THROUGH SIZE 112. SILVER BLADE LINK IS TO BE USED ON ALL FANS OF SIZE 125 AND LARGER.

AXICO® FPAC IMPELLER PARTS

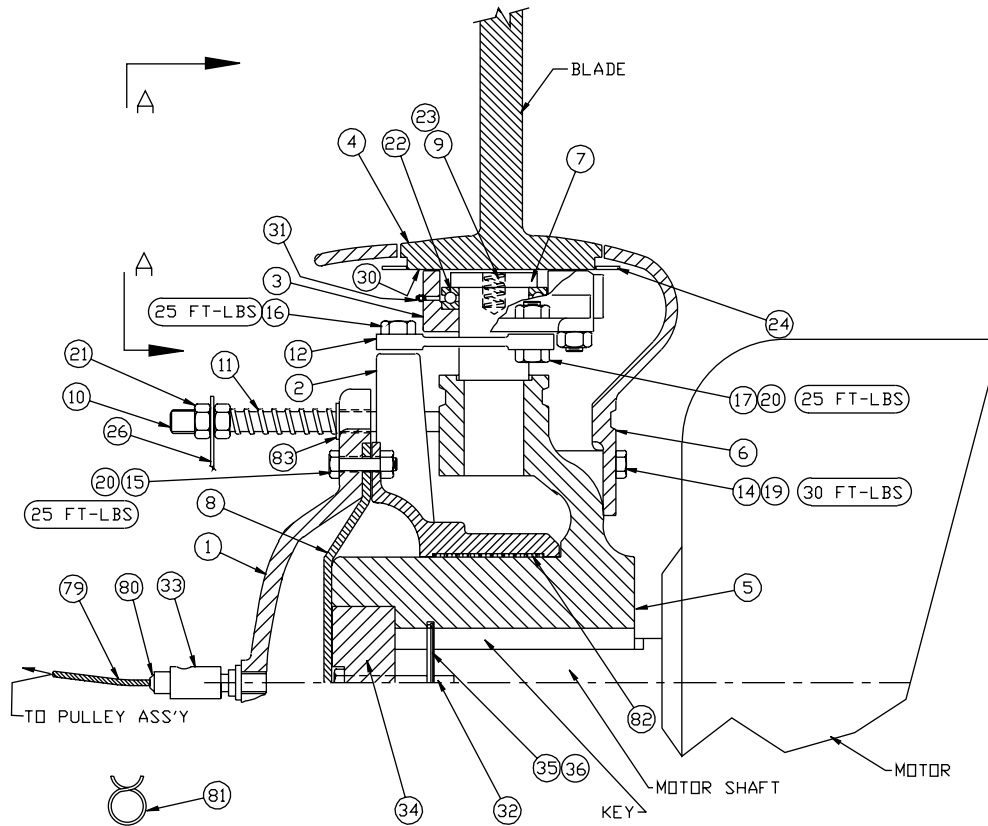

1. DIAPHRAGM COVER
2. SPIDER
3. BEARING HOUSING
4. BLADE
5. HUB
6. HUB FAIRING
7. SHAFT BLADE
8. DIAPHRAGM
9. PLUNGER
10. STUD
11. SPRING
12. LINK
13. SOC HD SCR
14. HEX HD SCR
15. HEX HD SCR
16. HEX HD SCR
17. HEX HD SCR
19. LOCK WASHER
20. HEX NUT
21. HEX NUT
22. BLADE BEARING
23. SPRING
24. AIR SEAL
26. PLATE
27. SOC HD C'SK SCR
28. NUT
30. GASKET
31. GREASE FITTING
32. ROTOR BOLT
33. ROTARY UNION
34. HUB WASHER
35. SNAP RING
36. THRUST WASHER
76. GREASE SEAL
77. WIRE SEAL
78. O-RING
79. CABLE ASS'Y
80. PAN HD SCR
81. HOSE CLAMP
82. TEFLON SLEEVE
83. OILITE BUSHING

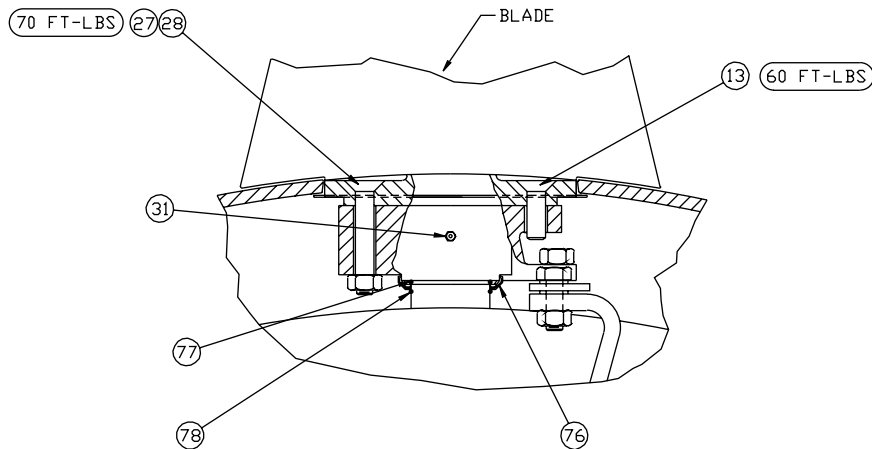

DWG.: 101236

AXICO® FPMC IMPELLER MODIFICATIONS

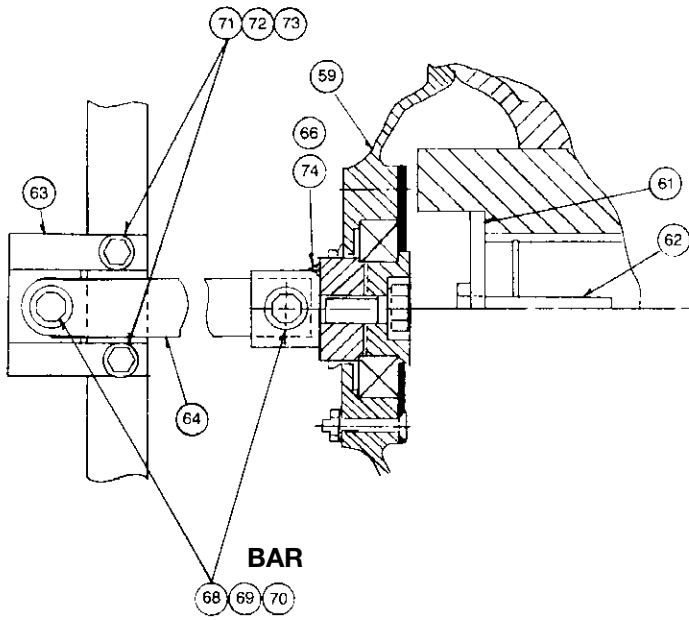

FPMC WITH BAR

- | | | |
|----|-------------------|---------|
| 59 | COVER, 5 OR 6 HUB | F301407 |
| | COVER, 8 HUB | F301408 |
| 61 | WASHER | |
| 62 | BOLT | |
| 63 | BEARING HOLDER | |
| 64 | ACTUATOR LINK | |
| 66 | GREASE | |
| 68 | BOLT | |
| 69 | NUT | |
| 70 | WASHER | |
| 71 | BOLT | |
| 72 | NUT | |
| 73 | WASHER | |
| 74 | FITTING, GREASE | |

JACTUATOR FPMC

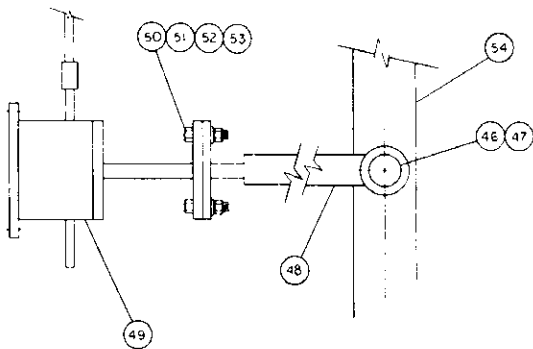

- | | | |
|----|--------------------|-----------|
| 46 | PIN | F1004306 |
| 47 | COTTER PIN | |
| 48 | CLEVIS | F10031508 |
| 49 | JACTUATOR | F100653 |
| 50 | BOLT 1/4-20 x 1.25 | F10032310 |
| 51 | NUT 1/4-20 | F10032403 |
| 52 | WASHER 1/2 | F10044603 |
| 53 | LOCKWASHER 1/4 | F10044703 |
| 54 | BAR | F201092 |

AXICO® FPDA IMPELLER PARTS

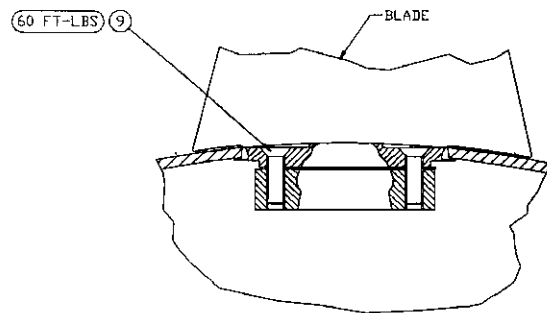
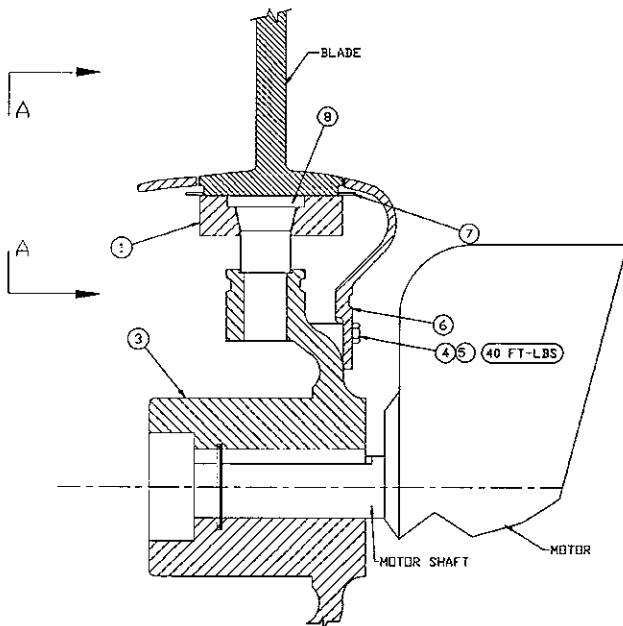

VIEW A-A

- | | | | |
|----|----------------|----|----------------------------------|
| 1. | BLADE RETAINER | 6. | FAIRING |
| | P/N F201328 | 7. | AIR SEAL |
| 2. | BLADE | 8. | BLADE SHAFT |
| 3. | HUB | | IF 050 OR 080 HUB: P/N F20132701 |
| 4. | HEX HEAD SCREW | | IF 063 HUB: P/N F20132702 |
| 5. | LOCK WASHER | 9. | BLADE BOLT: P/N F10022241 |

NEW MODEL NUMBER DESIGNATION AXICO® FANS

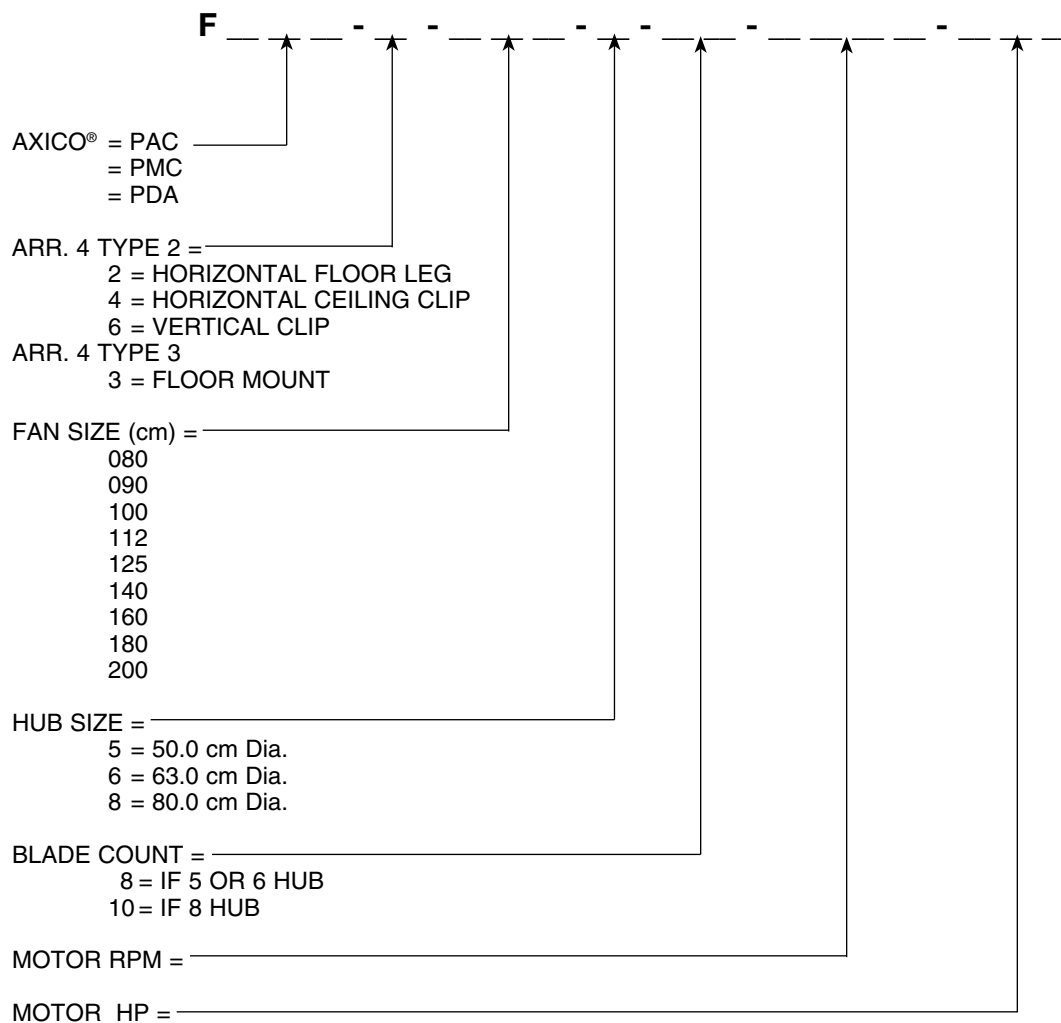

NOTES:

1. Motor frame size must be specified in the body of the order and will no longer be indicated within the model number.
2. Blade pitch must be indicated in the body of the order.

8.0 INSTRUCTIONS FOR LONG TERM STORAGE

- 8.1 If a fan is not installed immediately upon receipt, it is the responsibility of the purchaser/user to see to it that proper procedures are followed in order to minimize deterioration which may result from idle storage.
- 8.2 Fan equipment should be stored indoors or in a well sheltered location. The storage area must be clean and dry, well above any maximum anticipated water level. The equipment should be left crated/skidded, and not stacked over or under other equipment. Unpainted machined parts should be given a protective coating of Sprayon #322 or equal; this coating should be renewed periodically per the manufacturer's instructions. For fans equipped with vane sections, the core end cover should be removed to gain adequate access to the interior and reach the impeller hub. These interior areas require the same rust inhibitor application and renewal as given above. The cover should be replaced for storage, but each may be fastened with a minimum of assembly hardware to facilitate access. Remaining fastener hardware should be bagged and tagged, and attached to the fan to prevent loss of these items. (It is recommended that the fan be tagged indicating that all fasteners must be replaced before operation.)
- 8.3 Each impeller blade should be numbered in sequence with a felt-tipped marker. The blade marked No. 1 should be rotated to top center. The blade number and date should be recorded in a log book which is to be stored in a protective pouch attached to the fan. During storage, the fan impeller should be rotated by hand at least 10 revolutions every 30 days to circulate the lubricant in the bearings in the motor. After the tenth revolution, stop with a blade at top center which is not the same one as is listed for the previous date in the log book.
- 8.4 If the fan motor is equipped with internal heaters, the heaters must be energized throughout the storage period to prevent condensation which might damage bearings or electrical components. For motors not equipped with internal heaters, the motor should be enclosed in heavy-duty polyethylene, wrapped as tightly as possible.
Enclose bags of dessicant (such as Silicagel) with the motor to minimize moisture problems. Check the dessicant regularly and replace it periodically as dictated by climate requirements. In addition, it is strongly suggested that the motor manufacturer be contacted for specific long term storage instructions.
- 8.5 The bearings in the fan motor or on the fan shaft should require only minimum lubrication during storage. Follow lubrication instructions in the instruction manual enclosed with the fan.
- 8.6 After an extended period of storage, it is advisable to have the fan motor thoroughly checked before the fan is installed. Motor bearings, lubricant and electrical condition should be given special consideration. Reassemble cover to fan and follow AXIAD instruction manual for installation and start-up.

Aerovent Service Organizations

Aerovent Service Department
5959 Trenton Lane N.
Minneapolis, MN 55442
Phone: 763-551-7500
Fax: 763-551-7501

Air Performance Service, Inc.
10510 Markison Road
Dallas, TX 75238
Phone: 972-387-3334
Fax: 972-991-2902

Air Performance Service, Inc.
11921 Windfern Road
Houston, TX 77064
Phone: 713-979-0720
Fax: 713-979-0724

Air Performance Service, Inc.
8910 Research Blvd., Suite B2
Austin, TX 78758
Phone: 512-381-0200
Fax: 512-381-0204

Air Performance Service, Inc.
605 Avenue B, Suite 101
Longview, TX 75601
Phone: 903-240-3403
Fax: 214-635-2219

E/C Vibration & Balancing Service, Ltd.
720 Morse Avenue
Schaumburg, IL 60193
Phone: 847-352-7076
Fax: 847-352-8231

D.S. Hanback Company
14635 North First Avenue
Phoenix, AZ 85023-5201
Phone: 602-430-8948
Fax: By Arrangement Only

Long Building Technologies
5001 South Zuni Street
Littleton, CO 80120
Phone: 303-975-2100
Fax: 303-936-2755

Long Building Technologies
4689 S. Cherry Street
Murry, UT 84123-3619
Phone: 801-262-5664
Fax: 801-264-8884

Long Building Technologies
6560 Tioga Way
Las Vegas, NV 89113
Phone: 702-740-5100
Fax: 702-740-5143

Hahn-Mason Air Systems, Inc
P.O. Box 10465
Raleigh, NC 27605
Phone: 919-834-9230
Fax: 919-831-9714

Fred Williams, Inc.
320 Libbey Industrial Parkway
Weymouth, MA 02189
Phone: 781-961-1500
Fax: 781-335-3937

Longo Industries
1 Harry Shupe Blvd.
Wharton, NJ 07885
Phone: 973-537-0400
Fax: 973-537-0420

Cox Engineering Service Co.
Vane Axial Fan Division
35 Industrial Drive.
Canton, MA 02021
Phone: 781-302-3400
Fax: 781-302-3464



WWW.AEROVENT.COM

5959 TRENTON LANE N | MINNEAPOLIS, MN 55442 | PHONE: 763-551-7500 | FAX: 763-551-7501