



IM-100
April 2006

General Installation, Operation and Maintenance Instructions For Aerovent Products

Introduction

This manual has been prepared to guide the users of Aerovent equipment in the proper installation, operation and maintenance procedures to insure maximum equipment life and trouble-free operation.

Receiving

Products leaving the assembly plant have been inspected and are in satisfactory operating condition. The carrier assumes full responsibility for material from the time it leaves the plant until it is delivered to the user. Therefore, material should be inspected for damage immediately so that any damage claims against the carrier can be made before acceptance of the shipment. No equipment is to be returned without an authorized returned goods tag.

Handling

All products must be handled with extreme care to avoid misalignment of rotating components. Never lift a unit assembly by using the shaft, drive sheaves, wheel or motor as a point of attachment. If it is apparent that slings will not clear a portion of the product being hoisted, a spreader should be used to avoid damage.

Initial Operation

All Aerovent fans are lubricated at the factory and have been given a run-in test before shipment. Read carefully all installation and maintenance manuals before following the startup check list.

Safety Precautions

Any piece of machinery should be treated with respect and not overconfidence. Overconfidence usually leads to carelessness and carelessness leads to injury. Following is a list of DOs and DO NOTs:

DO

1. Make sure the unit is stopped and electrical power is locked out before putting hands into the inlet or outlet openings or near the belt drive. A warning sign on the START SWITCH cautioning not to start is recommended when the unit is being serviced.
2. Follow maintenance instructions.

DO NOT

1. Put hands near or allow loose or hanging clothing to be near belts or sheaves while the unit is running.
2. Put hands into inlet or outlet while the unit is running. It is sometimes difficult to tell whether or not a fan is running... be sure it is not running and cannot be operated before any inspection.

Startup Checklist

1. Inspect the equipment for any shipping damage. Remove any foreign material such as tags or packing from any moving parts or from within the fan housing.
 2. Compare the voltage, hertz, and phase stamped on the motor with the current characteristics of the line to which the motor is to be connected.
 3. Lock out the power source at the disconnect switch.
 4. Turn motor, drive, and propeller by hand to see that no misalignment has taken place in shipment. Check V-belt drive for proper alignment and belt tension.
 5. Check all bolts, screws and fasteners and tighten if necessary. Make certain all set screws, locking collars and bearing mounting bolts are secure.
 6. Secure and check clearance of access doors, belt guards and inlet and outlet guards.
 7. If equipped with dampers, check for correct linkage operation. Make sure that the operator opens or closes these control devices to the proper positions.
 8. Jog the fan electrically and note the rotation. Reverse two electrical leads, if necessary, to obtain proper rotation as marked with rotation arrow on fan. Do not allow the propeller to run backwards except momentarily.
 9. **Centrifugal Fans:** Close dampers as required for adequate system resistance to prevent the motor from overloading.
- CAUTION:** With fans that use the forward-curve or radial type of wheel, it is possible to overload the motor if the fan is operated at a lower static pressure than that which the fan is rated. Check the catalog rating of the fan for proper speed and resistance.
10. Start the fan and observe its operation.
 11. Take a motor amp reading and compare with the amp rating on the motor. (The actual running amps should not exceed motor nameplate amps x service factor, exceptions may be taken for air over motors.)

Fan Balance

Fan propellers are statically and dynamically balanced within acceptable tolerances at the factory. Damage in shipping and handling or poor installation of the unit may upset the unit balance. A propeller that is not properly balanced can lead to excessive vibration causing undue wear on the entire unit. It is recommended that after installation a vibration test be made on the fan by an experienced technician.

CAUTION: For units furnished less final drive components at customer request, the addition of drive components in the field can create critical vibration modes. Aerovent strongly recommends a final unit balance procedure after all rotating components are installed. Failure to do so voids Aerovent's warranty.

All Aerovent fan assemblies are statically and dynamically balanced to Balance Quality Grade G6.3. Each fan is factory run tested for vibration in accordance with ANSI/AMCA 204-96 "Balance Quality and Vibration Levels for Fans" to Fan Application Category BV-3, to the following peak velocity values, filter-in, at the fan test speed:

Fan Application Category	Rigidly Mtd. (in./sec.)	Flexibly Mtd. (in./sec.)
BV-3	0.15	0.20

Vibration measurements, when possible, should be taken at each fan shaft bearing in two planes perpendicular to the axis of rotation (planes to have 90 degree interval), and one measurement parallel to the axis of rotation. On direct drive units, the perpendicular measurements will be taken at each end of the motor casing, taking care not to take measurements on the fan shroud on TEFC motors. The axial measurement can be taken on the motor foot or mounting base. In some cases, primarily on axial flow units, it will not be possible to take measurements at the bearings or motor. On these units, the measurements should be taken on the inner shell near the bearings. If this is not possible, then take the readings on the outer shell near the bearing locations.

If vibration is excessive, shut down the fan and determine the cause.

Common Causes of Excessive Vibration

1. Support structure not sufficiently rigid or level. Vibration amplified by resonance in ductwork or support structure.
2. V-belt drive misalignment. Belt tension is too tight or too loose.
3. Bearing locking collar or mounting bolts loose. Propeller set screw loose.
4. Material accumulation on propeller.
5. **Centrifugal Fans:** Wheel rubbing on inlet cone.

Motors

Most integral horsepower totally-enclosed motors have drain plugs in the end bells for drainage of condensation. On all roof ventilators, the bottom or lower plug has been removed for continuous drainage.

All other style fans are shipped with the drain plugs installed. The user should remove the proper drain plug. For horizontally mounted units with the motor in the airstream, remove the downstream drain plug. For vertically mounted units, remove the bottom or lower drain plug.

With motors supplied by the user, drain plugs may not have been provided. Check with the motor manufacturer regarding drainage and condensation.

Lubrication Instructions for Ball Bearing Motors

Grease-lubricated bearings, as furnished, are adequate for a long period of operation without relubrication. A good maintenance schedule for regreasing will vary widely depending on motor size, speed and environment.

The table below suggests relubrication intervals for motors on normal, steady running, light duty indoor loads in relatively clean atmosphere at 40°C (105°F) ambient temperature or less. Fractional horsepower motors follow a schedule similar to that shown under frames 143T to 215T.

Motor Lubrication Intervals

TYPE OF ENCLOSURE	INSULATION	FRAME SIZE		
		143T-215T	254T-326T	364T-449T
Open-DP	B	2 yrs.	18 mos.	1 yr.
Enclosed-FC	B	18 mos.	1 yr.	9 mos.
Open-DP	F			
Enclosed-NV	B	1 yr.	9 mos.	6 mos.
Enclosed-FC	F			
Open-DP	H			
Enclosed-Lint	B	9 mos.	6 mos.	3 mos.
Free-FC	F			
Enclosed-NV	H			
Enclosed-Lint	F			

NOTE: For motors over 1800 RPM, use 1/2 of tabled period. For heavy duty, dusty locations, use 1/2 of tabled period. For severe-duty high vibration/shock, use 1/3 of tabled period.

VOLUME - REFERENCE TABLE

SHAFT DIAMETER (AT FACE OF BRACKET)	AMOUNT OF GREASE TO ADD
3/4" to 1 1/4"	1/8 cu. in. or 0.1 oz.
1 1/4" to 1 7/8"	1/4 cu. in. or 0.2 oz.
1 7/8" to 2 3/8"	3/4 cu. in. or 0.6 oz.
2 3/8" to 3 3/8"	2 cu. in. or 1.6 oz.

Motors with no provision for lubrication are equipped with sealed bearings and require no maintenance. Motors mounted in inaccessible locations are provided with extended grease lines to facilitate lubrication if provisions for lubrication are provided. The bearings are equipped with relief fittings to prevent over-lubrication. The grease lines are filled with lubricant at the factory.

Procedure for Relubrication

1. Stop motor.
2. Remove grease relief plugs in bearing housings.
3. Grease with hand gun until new grease appears at relief hole.
4. Run motor for ten (10) minutes before replacing relief plugs.

CAUTION: Do not over-lubricate. This is a major cause of bearing and motor failure. Make sure dirt and contaminants are not introduced when adding grease.

Type of Grease

Lubricate with the following greases or their equivalent:

- Amoco Rykon Premium #2
- Chevron BRB-2 – Standard Oil or Calif.
- SRI-2 – Standard Oil Company
- Alvania #2 – Shell Oil Company
- Mobilith AW2

For motors lubricated with special greases, check lubrication tag on motor.

Lubrication Instructions for Fan Ball Bearings

Bearings and grease lines on belt driven fans are lubricated in assembly. When lubrication is required, add grease slowly while the shaft is rotating until grease comes rapidly out of the seal.

For extreme conditions, lubricate according to experience. For normal conditions, lubricate the bearings with Mobilith AW2 or an equivalent.

Bearings and grease lines on axial fans that are ordered for high moisture or above normal temperatures have been lubricated with a special lubricant, Plastilube #2. Lubricate at regular intervals with Plastilube #2 as indicated in the special lubrication chart listed below. Plastilube #2 is available from Sulflo, Inc. 1158 Erie Avenue, North Tonowanda, New York 14120.

Special Lubrication Frequency For High Temperature and High Moisture

AIRSTREAM TEMPERATURE	HOURS
TO 250°F	4500
TO 350°F	1500
TO 500°F	1000
WET ATMOSPHERE AT ROOM TEMPERATURE	1000 TO 1500

Storage of Equipment Fan Bearings

Since bearings tend to “breathe” on equipment stored in areas with other than a constant temperature, moisture will condense internally. Therefore, it is necessary to keep the bearings completely full of grease and periodically rotated to make certain that all internal parts are coated with grease. Even a full bearing will eventually pick up moisture and, therefore, must be periodically purged with new grease.

Grease should be purged from the bearings to remove condensed moisture, and the fan wheel rotated by hand every thirty (30) days. This practice should be done more often if weather is severe or if there is a wide variation in temperature.

CAUTION IN PURGING: The fan should be rotated while greasing and high pressure pneumatic greasers should be avoided. See “Lubrication Instructions for Fan Ball Bearings.”

To rotate the fan, follow the procedure listed below:

The blade marked number 1 should be rotated to top center. The blade number and date should be recorded in a log book which is to be stored in a protective pouch attached to the fan. During storage, the fan propeller should be rotated by hand at

least ten (10) revolutions every thirty (30) days to circulate the lubricant in the bearings in the motor or on the fan shaft. After the tenth revolution, stop with a blade at top center which is not the same one as is listed for the previous date in the log book.

Fans which are V-belt driven should be prepared for storage as follows:

Carefully remove the belts, coil them (without kinks) in matched sets and place them in a heavy carton. Mark the carton with fan identification and store the carton in a dry, well-ventilated area. Belts must not be left exposed to sunlight or subjected to storage ambient conditions exceeding 85°F, 70% relative humidity. Belts which show signs of deterioration should be replaced prior to startup. Before reinstalling belts, review the section on “Belt Tension.”

NOTE: Procedures for storage of Aerovent equipment as outlined above are intended as a general guide only. Storage conditions will vary depending on the location. Common sense and practical experience should determine to what extent the above procedures will be followed.

Motors

Motors must be stored under cover in a clean, dry, vibration-free location. Remove sufficient packaging material to allow circulation of air around the motor. Maintain the temperature of the windings a few degrees above that of the surrounding air to protect against condensation. If the motor is equipped with internal heaters, the heaters should be energized throughout the storage period to prevent this condensation. If the motor does not have internal heaters, this can be accomplished using any other safe, reliable method of heating. Measure and record the ambient air temperature and winding temperature monthly.

In the event that the motor is not equipped with internal heaters and space heating equipment is unavailable, wrap the motor as tightly as possible with heavy duty polyethylene. Enclose bags of desiccant (such as silicagel) with the motor to minimize moisture problems. Check the desiccant regularly and replace it periodically as dictated by climate requirements.

To prevent rusting of bearing parts, the rotor must be rotated at regular intervals (30 days) to assure these parts are well covered with oil or grease.

Prior to energizing the motor, it is to be inspected and meggered by a motor manufacturer’s field service engineer. The charges for this service to the customer will be in accordance with the manufacturer’s published service rates in effect at the time of the inspection.

In addition, it is strongly recommended that the motor manufacturer be contacted for specific long-term storage instructions.

Lubrication Frequency for Horizontal Shaft Installations (see Note ① for vertical shaft installations)

SHAFT SIZE (INCHES)	LUBRICATION FREQUENCY ①									
	OPERATING SPEED (RPM)									
	500	1000	1500	2000	2500	3000	3500	4000	4500	5000
	RELUBRICATION CYCLE (MONTHS)									
½ - 1	6	6	6	6	6	6	4	4	2	2
1 1/16 - 1 1/16	6	6	6	6	6	6	4	4	2	1
1 1/2 - 1 3/4	6	6	6	4	4	2	2	2	1	1
1 7/8 - 2 3/16	6	6	4	4	2	2	1	1	1	
2 1/4 - 2 7/16	6	4	4	2	2	1	1	1		
2 1/2 - 3	6	4	4	2	1	1	1			
3 1/16 - 3 1/2	6	4	2	1	1	1				
3 15/16 - 4	6	4	2	1	1					

NOTES: ① Reduce this lubrication frequency schedule by half for vertical shaft installations.
 ② Consult manufacturer for specific recommendations.

Fan Bearing Replacement Procedure

It is important to follow the assembly and alignment procedure when making an installation of replacement bearings. Inspect the shaft for wear at the bearing mounting positions. Shaft diameter should not be undersized more than commercial ground and polished tolerances. Excessive undersizing will result in rapid wear.

1. Place new bearings loosely on the shaft. Locking collars may be located on either end of the bearings for ease of installation. The illustration shows one locking collar on the drive end and one locking collar on the fan end which is typical for a tubeaxial type fan. A typical SWSI centrifugal fan would have both collars mounted on the sheave side of the bearings. Drop the mounting bolts in place, snug them and adjust the position of the shaft with proper spacing at either end.
2. Center both ends of the shaft in the housing of tubeaxial fans using the propeller as a guide. On centrifugal fans, the shaft is positioned 90° to the scroll side with the wheel inlet centered in the scroll inlet. Use the clearance in the mounting holes for horizontal adjustment and shims, if necessary, for vertical adjustment.

Figure 1. Two Bearing Drive

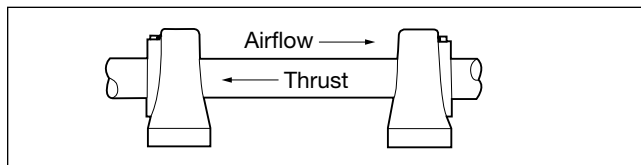

3. Tighten the bearings to the base plate and check the position of the shaft again. Before tightening the locking collars, be sure the shaft and bearings are in proper alignment. The shaft should slide freely end to end.
4. Tighten the eccentric cam locking collar of the bearing at the propeller/wheel end. (The locking collar design provides a positive lock of the wide inner ring bearing to the shaft. To tighten, turn the locking collar in the direction of shaft rotation to the lock position, then tighten the collar set screw.) Repeat this procedure for the sheave end locking collar on DWDI and open wheel centrifugals. For other fan types, proceed to Step 5.
5. Axial flow propellers and single inlet centrifugal wheels with back plates exert an air thrust toward the fan inlet. To help balance the bearing loading, we allow the fan end bearing (belt driven units) to carry the majority of this thrust loading while the sheave end bearing carries most of the radial load. (Direct coupled units would be just the opposite.) To accomplish this, grasp the sheave end of the shaft and pull or push on it toward the fan inlet. At the same time, tap the locking collar of the sheave end bearing (fan end on direct coupled units) in the opposite direction with a soft mallet.
6. The final step is to tighten the sheave end bearing eccentric cam locking collar while maintaining constant pressure on the shaft toward the fan inlet.

For special heavy duty bearings, a spring locking collar is used. The two knurled cup-point set screws extend through the inner ring of the bearing and lock firmly onto the shaft. Tighten the propeller end collar first, then take hold of the sheave end of the shaft, pull and then tighten the locking collar. The locking collar is tightened by using the two set screws mentioned above.

Replacing Fan Belts

Worn belts may be easily replaced without removing the fan from the system.

1. Loosen the motor hold-down bolts and move the motor toward the fan. (This is done by turning a jackscrew which is a part of the motor base on models having larger motors.) The belt may be slipped off the motor sheave and then easily removed from the sheave on the propeller shaft.
2. Check the numbers on the belt and make the replacement with a belt having the same length and section.
3. Adjust the motor outward to tighten the belt (see instructions on belt tension, below) and tighten the motor hold-down bolts. Be sure that the motor is not cocked at an angle and that the end face of the motor sheave is parallel to the end face of the driven sheave.

Belt Tension Procedure

Belt tension is very important to the proper operation of a fan and to the service life of a V-belt drive. A new fan will be received with its belts properly adjusted; however, all V-belts stretch in the first few hours of operation. It is necessary to readjust the belt tension after eight hours of running. After 100 hours the belts should again be adjusted. Thereafter, periodic inspection is recommended so belts may be adjusted or replaced when necessary.

1. To adjust the belts, loosen the motor hold-down bolts. Tighten the belt using the motor base adjusting screw until the belt appears to be taut. You should be able to deflect the belt slightly by squeezing the two sides between thumb and forefinger and the belt should snap back into position when released.
2. Retighten the motor hold-down bolts and start the fan. If the belt screeches on startup it is too loose and should be tightened further.
3. Allow the fan to run for a while, stop the fan, and check the temperature of the sheave with your hand. If the sheave is too hot to touch, the belt is probably too tight.

V-belt drives on Aerovent fans are purposely sized to handle considerably more load than would be necessary for normal drive design. This is done to prolong the life of the drive and provide for minimum maintenance. Belts should be replaced when they have obviously become worn, even though they are still operating. A badly worn belt will also cause undue wear of the sheave. Replace belts when they show definite signs of wear; otherwise the sheaves will become worn to the point where they also must be replaced. Never put new belts on a badly worn sheave. This will reduce the capacity of the drive and cause excessive belt wear.

Most Aerovent fans are provided with an adjusting screw as a part of the motor base for easy setting of belt tension. However, small fans or fans using small horsepower motors may have only a slotted base plate. When the belt tension is adjusted by moving a motor on a slotted base, be sure to block the motor tightly and squarely before tightening the hold-down bolts, keeping the motor sheave in line with the belt. The motor sheave must be parallel to and in line with the fan sheave.

When you make replacement of belts on a multi-groove drive, be sure they are used in a matched set. If you are not sure the belts are matched, observe them in operation. The tight side should be perfectly straight and the belts should run smoothly and in line. The slack side should bow out and also be in line. If one of the belts extends out considerably farther than another, it is an indication that the belts are not matched and should be changed. If there is only a slight difference, the normal stretching in the first hours of operation will equalize the belt lengths and the belts will be well matched.

Adjusting Variable Pitch Sheaves

Many Aerovent belt driven fans are furnished with variable-pitch motor sheaves. Sheaves may be adjusted for lower fan speeds without concern of overloading motors. When adjusting sheaves to increase the fan speed, check the motor current to be sure the motor is not overloaded. Keep the motor current within the nameplate and service factor ratings.

The sheaves used are easily adjusted. They come in various styles, depending upon the size drive and motor shaft. They are all fitted with hollow head knurled point safety set screws.

The following steps should be taken to adjust the pitch diameter.

1. Release belt tension and remove the belt or belts from the sheave.
2. Loosen the set screw and remove the key holding the adjustable half of the groove (keys used on styles 2, 3, 5 and 6 only). With styles 3 and 6, it may be necessary to remove the sheave from the shaft to remove the key.
3. Rotate the adjustable half of the sheave out for a smaller pitch diameter (decreased speed) or in for a larger pitch diameter (increased speed). Each one-half turn will change the pitch diameter one-tenth of an inch. Adjust two-groove sheaves the same amount on each groove. 4L or A belts will operate satisfactorily with the sheave fully closed to a maximum of five full turns open. 5L or B belts will operate satisfactorily with the sheave one full turn open to a maximum of six full turns open. (This will insure full contact of the sheave in the groove.)
4. Replace the key and tighten the set screw to lock the sheave half in position.
5. Replace the belts and tighten to the proper tension. If an extreme amount of adjustment has been made, it may be necessary to replace belts with another length.

Figure 2. Types of Sheaves

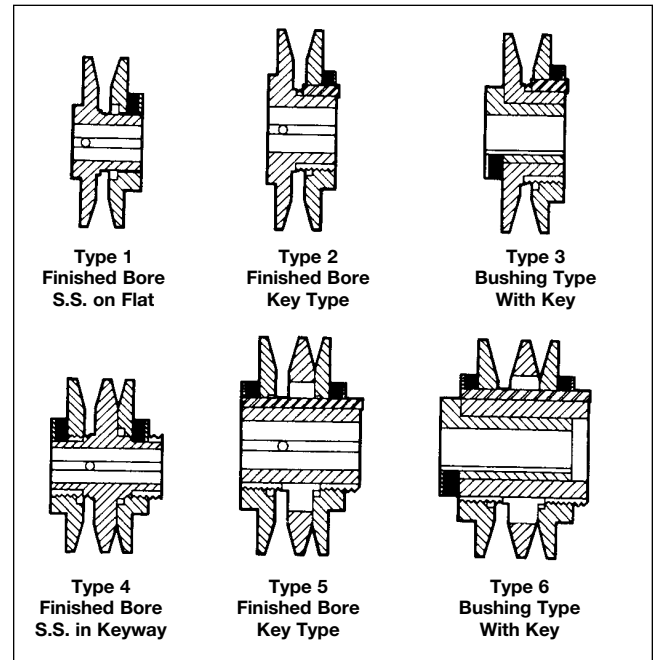

V-Belt Drive Alignment

Proper alignment and balance of the V-belt is as important as a well-balanced propeller. To insure smooth fan operation, the following should be checked:

1. The fan and motor sheaves must be in axial alignment. Shafts are parallel in both the vertical and horizontal planes (Figure 3).

Figure 3. Fan and Motor Sheave Axial Alignment

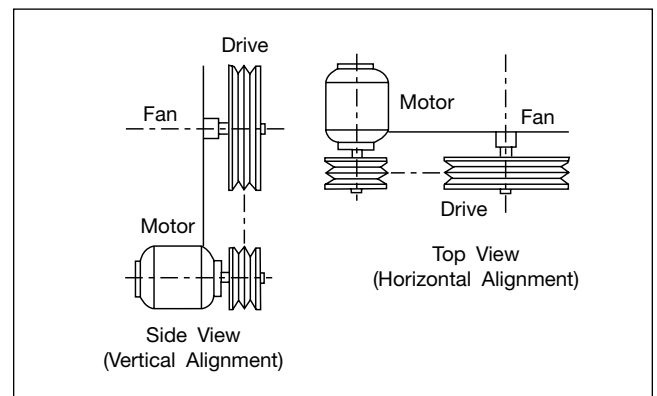

2. The fan motor sheave must be in radial alignment. When sheaves are of equal width, align with a straightedge (Figure 4a). When sheaves are of unequal width, align the center of the sheaves (Figure 4b).

Figure 4. Sheave Alignment

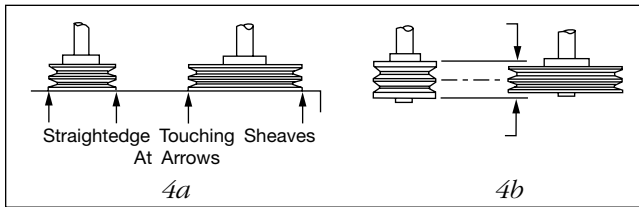

3. Sheaves must have no noticeable eccentricity.
4. Belts must have the proper tension. Belts either too loose or too tight cause vibration and excessive wear (Figure 5). See instructions for belt tension adjustment procedure.
5. After proper installation of drives, recheck the complete assembly for smoothness of operation.

Figure 5. Proper Belt Tension

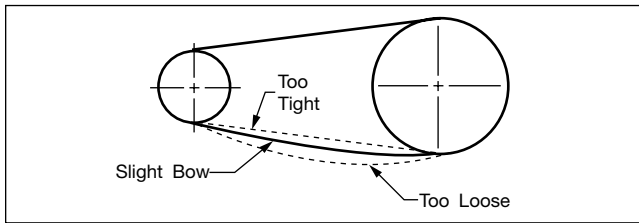

Flexible Couplings

Direct-coupled fans, which are received factory assembled, on a common base plate, are accurately aligned before shipment. However, base plates are flexible to some extent and therefore must not be relied upon to maintain the factory alignment. Realignment is necessary after the fan has been leveled, grouted, and the foundation bolts tightened. Also, check the lubricant, where applicable, following the manufacturer's recommendations for the type and amount of lubricant.

For field installation, the coupling should be mounted as follows:

1. Remove dirt or rust from fan and motor shafts and coat with grease or oil for ease of mounting.
2. Check fan and fan shaft alignment, making sure that the bearings are secure. Mount the fan shaft coupling half flush to the end of the shaft and secure.
3. Mount the motor shaft coupling half flush to the end of the shaft and secure.
4. Move the motor into position, with the coupling faces separated by the coupling manufacturer's specified gap.
5. With a straightedge, tapered wedge, or a feeler gauge, check for parallel and angular alignment (Figure 6a).
6. Align the shafts until a straightedge appears to be parallel to the shafts. Repeat at three additional points at approximately 90° from each other (Figure 6b). Recheck the hub separation gap.
7. For more accurate alignment, use a dial indicator clamped on one hub. With the dial button resting on the other hub, rotate the hub on which the indicator is clamped and observe the indicator reading. Take readings at four locations, 90° apart. With correct alignment, the faces of the couplings should be parallel within 0.002".
8. Once proper alignment is assured, secure the motor, examine the alignment, complete the assembly, and lubricate the coupling (when required) before putting the unit into operation.

Figure 6. Flexible Coupling Alignment

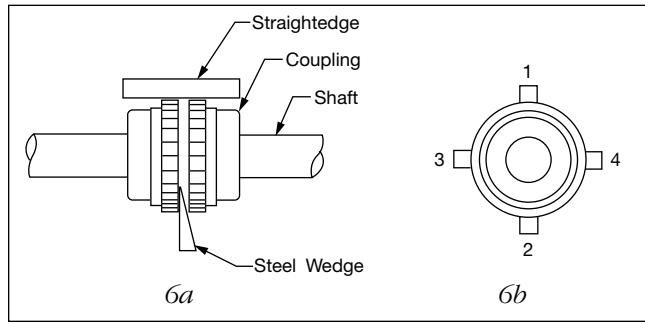

Propeller/Wheel Alignment

Fans, which are received factory assembled, have the propellers already aligned and in place before shipment. However, fans being flexible to some extent are sometimes subject to movement during shipment. To insure smooth operation and proper performance, the following propeller alignment should be checked before putting a fan into operation.

Propeller Fan Alignment

The fan shaft should be centered and parallel to the fan casing. Center by checking gap (B) between the propeller tip and the fan casing. Repeat at three additional points at approximately 90° from each other (Figure 7b). Parallelism can be observed by measuring the axial distance (A) from one blade to the end of the fan casing at four points at approximately 90° from each other (Figure 7a).

Figure 7. Propeller Fan Alignment

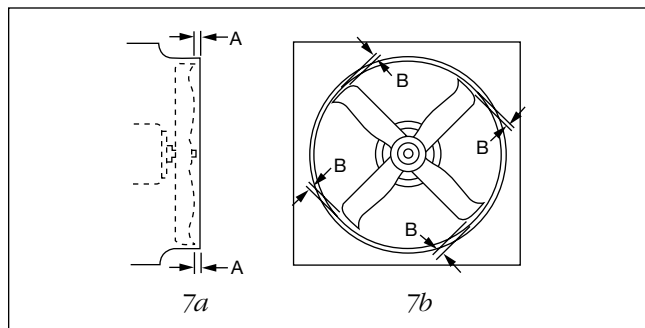

Do not confuse parallelism with blade track (axial deviation of one blade to another). Blade track can be checked by measuring the axial distance from one point on the fan casing to the same point on each blade as it passes by. (Some blades are mistracked for balancing.)

While checking the propeller alignment, it is good practice to check its rotation. Normally the fan rotation is marked by arrows on both the propeller and the fan casing. If omitted, obliterated, or misapplied, check for proper rotation as in Figure 8.

Figure 8. Checking for Proper Rotation

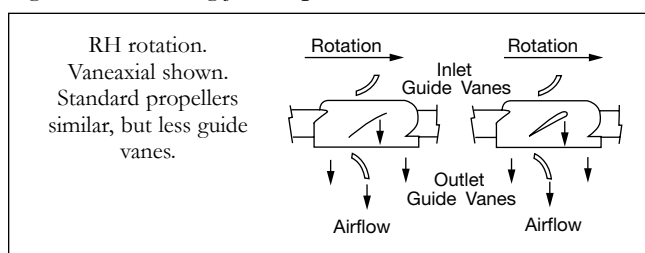

Centrifugal Fan Alignment

The fan shaft should be approximately centered in the clearance hole in the fan housing and perpendicular to the housing sides.

Adjust the clearance by moving the wheel axially on the shaft. The following table indicates the correct measurements for positioning the BI and BIA wheels. Proper positioning is important in attaining correct fan performance, particularly on the BI and BIA wheels.

Type CB & CBA (SWSI Units)

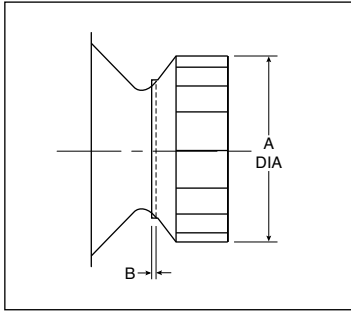

CB & CBA SWSI Wheel Placement											
Size	122	135	150	165	182	200	222	245	270	300	330
A	12.25	13.50	15.00	16.50	18.25	20.00	22.25	24.50	27.00	30.00	33.00
B	0.32	0.34	0.38	0.44	0.56	0.63	0.69	0.75	0.88	0.97	1.06

Size	365	402	445	490	542	600	660	730	807	890
A	36.50	40.25	44.50	49.00	54.25	60.00	66.00	73.00	80.75	89.00
B	0.94	1.03	1.13	1.25	1.38	1.56	1.69	1.88	2.09	2.28

“B” dimension must be held. This dimension is critical to fan performance.

Type BIUB

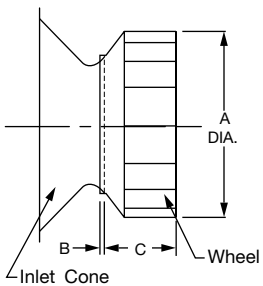

SIZE	A	B	C
12	12.25	0.32	4.28
14	13.50	0.34	4.84
15	15.00	0.38	5.38
16	16.50	0.44	5.81
18	18.25	0.56	6.44
20	20.00	0.63	7.00
22	22.25	0.69	7.84
24	24.50	0.75	8.63
27	27.00	0.88	9.47
30	30.00	0.97	10.56
33	33.00	1.06	11.63
36	36.50	1.10	13.03

Type CA, BW, OW, PB & HPB

These radial blade wheels do not require precise positioning to attain the correct performance. The important thing is to centrally locate these wheels axially within the housing to insure adequate running clearance and to maintain concentricity with the fan inlet.

Type AW

These wheels require a special inlet on the housing which must extend into the wheel inlet flange to perform properly. Other than maintaining a minimum 1/4" overlap, adequate running clearance and concentricity are all that is required.

Type FC

The forward curve blower employs a shallow venturi in the housing to guide the air into the wheel. The depth of this venturi is approximately one-tenth the wheel diameter. Clearance between the wheel and venturi should be the smallest allowable and still maintain normal running clearance. This axial separation is approximately 1/4" and should be measured at four points approximately 90° apart.

Installation Instructions for Propellers Equipped with Browning Malleable Iron Split Taper Bushings

Many Aerovent fans are furnished with split taper bushings for mounting the propeller to the shaft. When properly assembled, the bushings grip the hub with positive clamping action.

1. The bushing barrel and the bore of the propeller are tapered. This assures concentric mounting and a true running propeller.
2. Capscrews, when tightened, lock the bushing in the propeller. Use special plated capscrews threaded full length furnished by Aerovent.
3. The bushing is split so that when the locking capscrews force the bushing into the tapered bore, the bushing grips the shaft with a positive clamping fit. This will withstand vibration and punishing loads without being loosened.
4. The propeller and bushing assembly is keyed to the shaft and held in place by compression. This gives added driving strength.

Before assembly, be sure that the shaft and keyway are clean and smooth. Check the key size with both the shaft and bushing keyways.

5. To assemble, put the capscrews through the clearance holes in the bushing and put the bushing loosely into the propeller. Do not press or drive. Start the capscrews by hand, turning them just enough to engage the threads in the tapped holes on the propeller. Do not use a wrench at this time. The bushing should be loose enough in the propeller to move slightly. Slide the propeller and bushing assembly onto the shaft, making allowance for end play of the shaft to prevent rubbing. Install the key into the keyway. Do not force the propeller and bushing onto the shaft. If it does not go on easily, check the shaft, bushing and key sizes once again.

Tighten the capscrews progressively with a wrench. Do this evenly as in mounting an automobile wheel. Tighten each cap screw part of a turn successively until all are tight. These capscrews force the taper bushing into the hub which in turn compresses the bushing onto the shaft. This makes a positive clamping fit. The torque must not exceed that shown in the table on page 8.

WARNING: Do not attempt to pull the bushing flange flush with the hub end. There should be a clearance which varies approximately 3/16" to 1/4" with the bushing size when tightened. (Note: This is not a locating dimension.)

Capscrew Torque Values

BUSHING NO.	DIAMETER	LENGTH (IN.)	TORQUE FT. LBS.
H	1/4-20	1 1/4	7 1/2
P-1	5/16-18	1 1/2	13
P-2	5/16-18	1 3/4	13
Q-2	3/8-16	2 1/2	24
R-2	3/8-16	3	24

Removing Propeller Assembly from Shaft (see Figure 9)

1. Remove all capscrews from the propeller and hub assembly.
2. Start capscrews into the threaded holes in the bushing flange.
3. Tighten each bolt successively part of a turn to force the propeller off the bushing. This forces the bushing loose from the propeller and releases the compression so that the entire assembly will slide from the shaft.
4. Pull the bushing off the shaft. If the assembly has been in place some time, it may be necessary to use a wheel puller to remove the bushing. Never use a wheel puller on the propeller.

Figure 9. Removing Propeller Assembly

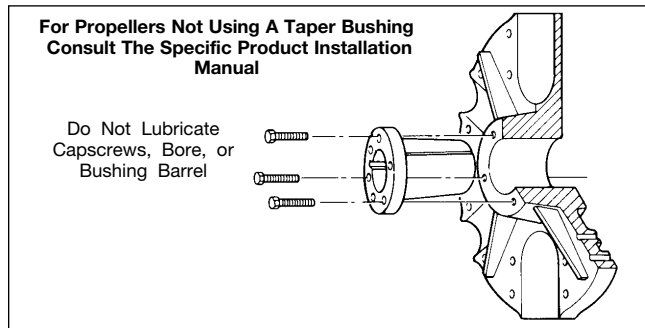

Typical Motor Current and Starter Size

Ampers shown in the table below are nominal and were used for sizing of the starters only. These values are **not** to be used for sizing heaters or other overload protection. Consult the motor nameplate for the correct motor current and refer this to the heater size chart for the particular starters used.

NOTE: When sizing overload heaters, conditions under which the starters will operate must be considered. Enclosed starters should have heaters one size larger than open starters. Where enclosures are subjected to external heat, such as radiant heat from the sun or heat accumulation under a roof, it may be necessary to increase the size even more. Experience with the operating conditions and measurement of the actual line current will aid in proper sizing of heaters.

Typical Motor Current and Starter Size

HP	THREE PHASE						SINGLE PHASE			
	230V		460V		575V		115V		230V	
	AMPS	STARTER	AMPS	STARTER	AMPS	STARTER	AMPS	STARTER	AMPS	STARTER
1/4		00		00		00	5.8	00	2.9	00
1/8	1.7	00	0.9	00		00	7.2	00	3.6	00
1/2	2.0	00	1.0	00	0.8	00	9.8	0	4.9	00
3/4	2.8	00	1.4	00	1.1	00	13.6	0	6.9	00
1	3.5	00	1.8	00	1.4	00	16.0	0	8.0	00
1 1/2	5.0	00	2.5	00	2.0	00	20.0	1	10.0	0
2	6.5	0	3.3	00	2.6	00	24.0	1	12.0	0
3	9.0	0	4.5	0	4.0	0	34.0	1	17.0	1
5	15.0	1	7.5	0	6.0	0			28.0	1
7 1/2	22.0	1	11.0	1	9.0	1			40.0	2
10	27.0	2	14.0	1	11.0	1			50.0	3
15	40.0	2	20.0	2	16.0	2				
20	52.0	3	26.0	2	21.0	2				
25	64.0	3	32.0	2	26.0	2				

For larger motor sizes, refer to National Electric Code.



Aerovent

A Twin City Fan Company

5959 Trenton Lane · Minneapolis, MN 55442-3237

Phone (763)551-7500 · Fax (763)551-7501 · www.aerovent.com

